

BINAURAL or STEREOPHONIC?

See page 22

JANUARY
1953
35c

AUDIO ENGINEERING

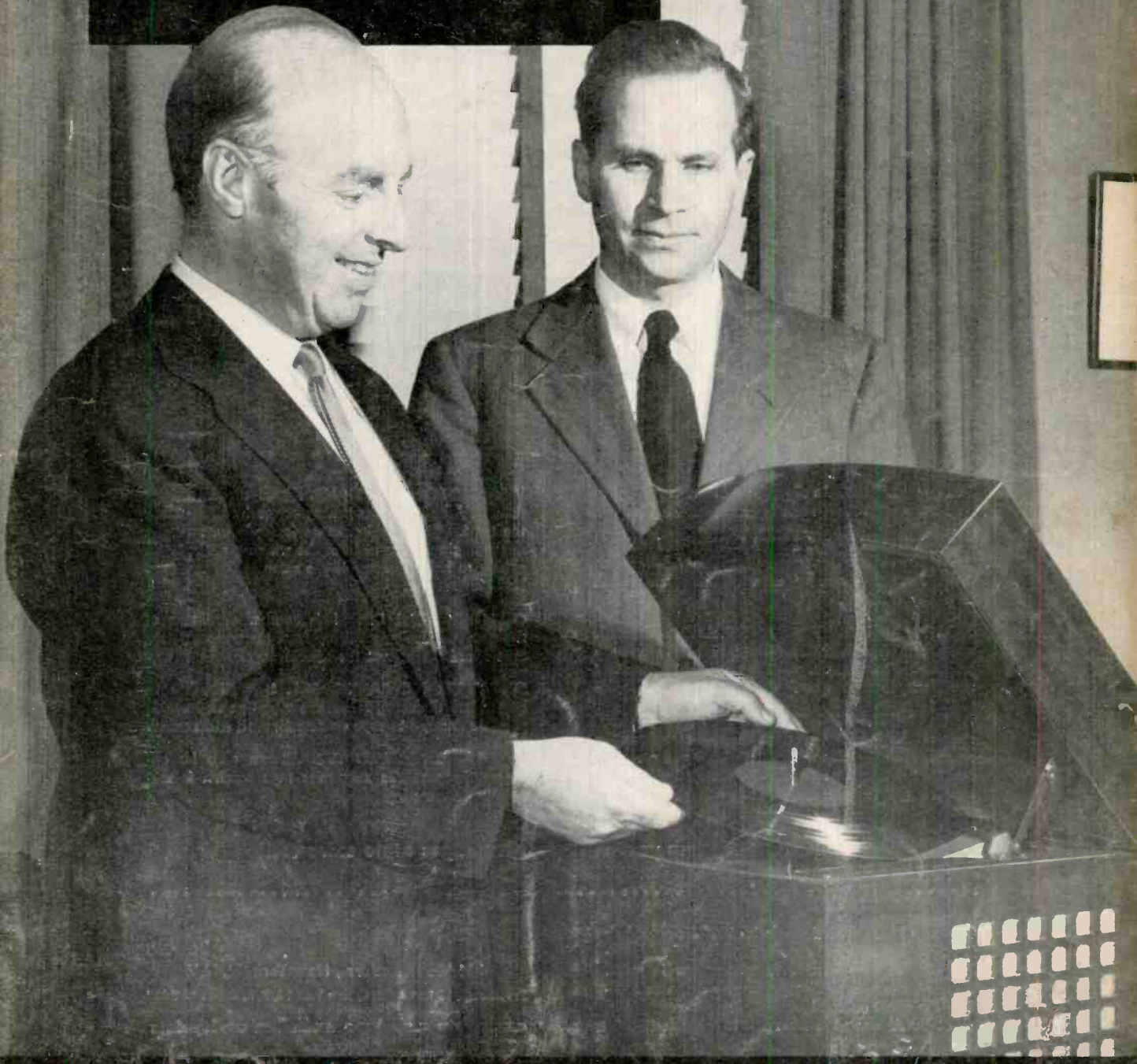

THE WORLD OF SOUND

the **RIGHT COMBINATION** for
maximum performance at minimum cost

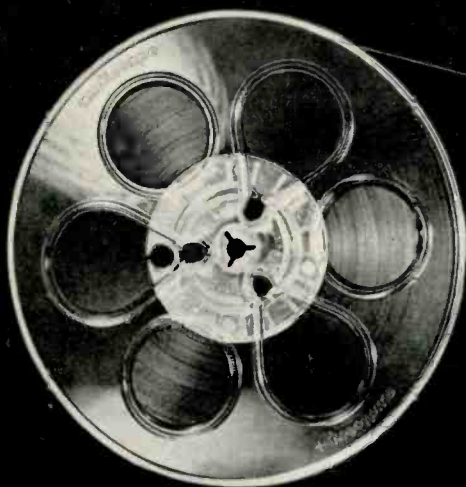

audiotape*

that meets the most exacting
professional requirements

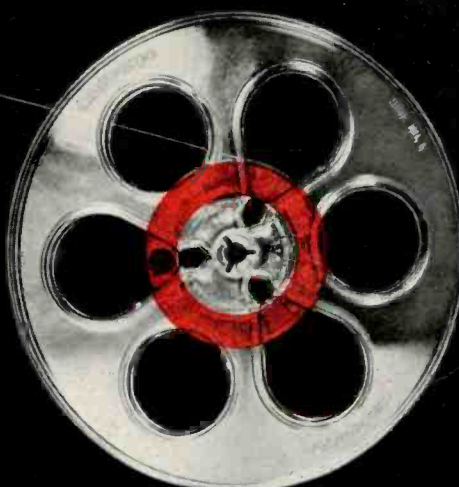

NEW 7" REEL

that eliminates the
"high-tension" zone

NO SPLICES. As always, plastic-base Audiotape in 1200 and 2500 ft reels is guaranteed *splice-free*.

NO FRICTION SQUEAL. Perfected anti-friction process eliminates annoying tape squeal—prevents "tackiness" even under extreme temperature and humidity conditions.

MINIMUM DISTORTION. Audiotape's oxide coating is especially formulated to give *maximum undistorted output*. Comparative tests show its marked superiority in this respect.

MAXIMUM UNIFORMITY. All 7" and 10" reels of plastic-base Audiotape are *guaranteed* to have an output uniformity within $\pm 1/4$ db—and a reel-to-reel variation of less than $\pm 1/2$ db. And there's an actual output curve in every 5-reel package to prove it!

PRECISION TIMING. Improved reel design with $2 3/4$ " hub reduces timing errors by eliminating the tension and speed changes formerly encountered at the beginning and end of the winding cycle. Ratio of OD to hub diameter is the same as the standard NAB 2500 ft reel.

CONSTANT PITCH is another advantage of the new reel design resulting from the more uniform tape speed throughout the winding cycle.

SLOWER ROTATIONAL SPEED, due to larger hub diameter, minimizes vibration and avoids possible damage to tape on fast forward and rewind.

REDUCED HEAD WEAR can also be expected, because the maximum tape tension is materially decreased.

audiotape gives you all these advantages at no extra cost!

* Trade Mark

This new 1200 ft plastic reel with $2 3/4$ " diameter hub is now being supplied on all orders for 7" reels unless otherwise specified... at no increase in price. Remember— with Audiotape, there's only *one* quality—the finest obtainable! Audiotape is available in all standard size reels from 150 to 5,000 feet.

AUDIO DEVICES, Inc.

444 Madison Ave., New York 22, N. Y.

Export Dept. 13 East 40th St., New York 16, N. Y., Cables "ARLAB"

audiodiscs audiotape audiotape audiotape audiotape

Successor to **RADIO** —Established 1917

AUDIO ENGINEERING

INCLUDING



C. G. McProud, Editor and Publisher

Harrie K. Richardson, Associate Editor
Eve Drolet, Production Manager
Edgar E. Newman, Circulation Promotion
Elizabeth Beebee, Circulation Manager

Edgar M. Villchur, Contributing Editor
Henry A. Schober, Business Manager
S. L. Cahn, Advertising Director
H. N. Refzes, Advertising Manager

Editorial Advisory Board

Howard A. Chinn
John D. Calvin
C. J. LeBel
J. P. Maxfield
George M. Nixon



Representatives

H. Thorpe Covington, Special Representative
677 N. Michigan Ave., Chicago 11, Ill.
Sanford R. Cowan, Mid-West Representative
67 W. 44th St., New York 18, N. Y.

West Coast

James C. Galloway J. W. Harbison
816 W. 5th St., Los Angeles 17, Calif.

CONTENTS

JANUARY, 1953

Vol. 37, No. 1

Audio Patents—Richard H. Dorf	2
Letters	8
Binaural Radio Broadcasting—Harold T. Sherman	14
Editor's Report	16
Practical Aspects of the R-J Speaker Enclosure—William Joseph and Frank Robbins	19
Simple Zero-Impedance Output Stage—R. G. Anthes	21
Binaural or Stereophonic?—R. J. Tinkham	22
Converting the RJ-12 for Binaural Reception—C. G. McProud	25
A Flexible Single Recording and Dubbing Channel—Hal Magargle	28
Handbook of Sound Reproduction—Chapter 8—E. M. Villchur	30
Great Loudspeaker Mystery—H. A. Hartley	33
The Protection of Ideas—Albert Woodruff Gray	36
The Audio Fair—Los Angeles	38
Making the Best of an Audio Transformer—N. H. Crowhurst	40
Record Revue—Edward Tatnall Canby	46
Equipment Report	56
New Products	58
New Literature	63
Employment Register	63
Price and Product Changes—Radio's Master Reports	78
Industry Notes	79
Advertising Index	80

COVER

Snowstorms in July are commonplace compared with pictures of table-model phonographs on the cover of *Æ*. They are no more newsworthy than this one, however. Developed by Dr. Peter Goldmark (right), for Columbia Records, Inc., the instrument offers a standard of audio performance never before approached in a unit of comparable size. At the left is Andre Kostelanetz, celebrated conductor, whose musical ear Dr. Goldmark borrowed more than frequently in designing the equipment.

RADIO MAGAZINES, INC., P. O. BOX 629, MINEOLA, N. Y.

AUDIO ENGINEERING (title registered U. S. Pat. Off.) is published monthly at 10 McGovern Avenue, Lancaster, Pa. by Radio Magazines, Inc., Henry A. Schober, President; C. G. McProud, Secretary. Executive and Editorial Offices: 204 Front St., Mineola, N. Y. Subscription rates—United States, U. S. Possessions and Canada, \$3.00 for 1 year, \$5.00 for 2 years; elsewhere \$4.00 per year. Single copies 35c. Printed in U. S. A. All rights reserved. Entire contents copyright 1952 by Radio Magazines, Inc. Entered as Second Class Matter February 9, 1950, at the Post Office, Lancaster, Pa. under the Act of March 3, 1879.

AUDIO ENGINEERING • JANUARY, 1953

GOOD NEWS!

the
REK-O-KUT
TURNTABLE
with the
HYSTERESIS
MOTOR
is **AGAIN**
AVAILABLE!



Nothing Else
Can Compare!

REK-O-KUT
Models T-12H and T-43H

EQUIPPED WITH THE
Hysteresis Synchronous Motor

... the only dual speed, 12" turntables that meet the standards for speed regulation and wow content specified by the National Association of Broadcasters... and recommended by every leading Sound Authority for use with ULTRA HIGH FIDELITY Amplifiers and Speaker Systems.

T-12H... 78 and 33 1/2 RPM... \$119.95

T-43H... 33 1/2 and 45 RPM... \$119.95

ACCESSORIES:

T-103A... 45 RPM idler, with record adaptor interchangeable with 33 1/2 RPM.

T-104A... 78 RPM idler interchangeable with 45 RPM.

REK-O-KUT CO.

38-01 Queens Blvd., Long Island City, N. Y.

EXPORT DIVISION: 458 Broadway, New York City, U. S. A.
CANADA: ATLAS RADIO CORP., LTD., 569 Bloor St. W., Toronto 28, Ontario

potentiometers



Sincromount

Linear and functional output, rugged construction, ball bearings, small size, low torque, synco-type mount.



Rectipot

Push-pull motion, linear and functional output, high resolution, rectilinear potentiometer.

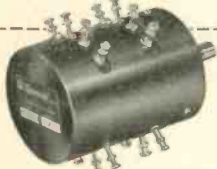

Jangpot

Functional and linear outputs, coils independently adjustable, variety of flexible assemblies.



Microtorque

Linear output, minimum torque, potentiometer and selsyn outputs, most ultra sensitive of them all.

These potentiometers are available in a variety of resistance values and circuits. For details on these and other fine instruments, write:

G. M. GIANNINI & CO., INC.
Pasadena 1, Calif.

Giannini

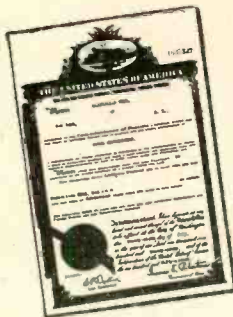

AUDIO PATENTS

RICHARD H. DORF*

MAGNETIC RECORDING has certainly come a long way since Poulsen's original methods, and most of the progress has been made in the last very few years. One of the problems in obtaining good fidelity with wire and tape is the non-linearity of the B-H curve of the medium. That was solved by Poulsen (and until a relatively short time ago) by superimposing a d.c. bias on the sound. But more recently a.c. bias has become standard.

The field is still new enough, however, from the standpoint of concentrated development and commercialization, to allow the thought that perhaps a.c. supersonic bias may not be the very best bias method. Lawrence H. Connell of Detroit, Mich., proposes a new and unfamiliar system which deserves a good look, at least by those interested in top-quality reproduction. Without experimentation the writer is unable to even begin to pass judgment on it, but Connell's idea is at least well worth examination. It is explained in his patent No. 2,604,546.

Figure 3 shows a magnetization curve which might represent that of a typical

recording medium such as the tape commonly in use. For various values of magnetizing force H exhibited by the head, the curve shows values of magnetization B left on the tape. Assuming the tape to be initially unmagnetized, applied values of H between a and a' produce magnetization values between b and b' . Values of H greater than that produce proportionally much larger magnetization. Obviously the steps in the curve will produce distortion if nothing is done.

The distortion is commonly removed by applying a steady a.c. bias which effectively eliminates the step and places the entire recording on the linear portions of the curve. A.c. bias has, however, some effect on higher frequencies; it either fails to record them or erases them to some extent. It is common knowledge that the correct bias value is a compromise between low distortion and good frequency response, the failings in the latter respect usually being made up if possible by additional equalization. D.c. bias, of course, allows use of only half of the available linear portion of the curve and the signal-to-noise ratio is relatively poor.

* 255 W. 84th St., New York 24, N. Y.

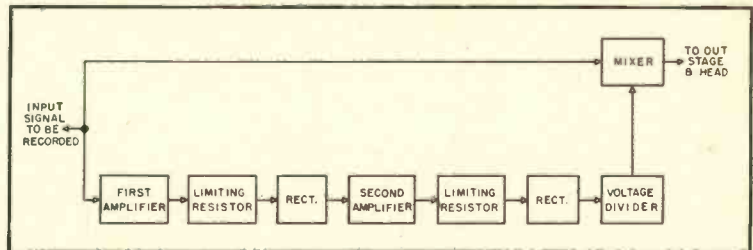

Figure 1.

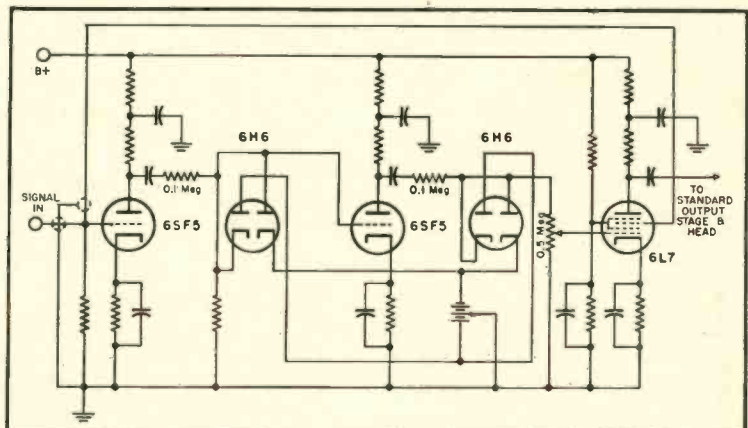

Figure 2.

British Industries Corp.

takes pleasure in offering to discriminating American music listeners, engineers and manufacturers, the finest sound and electronic equipment produced in Great Britain!

You may purchase every British Industries product with confidence, knowing...

- That it has been rigorously tested and chosen as the best of its kind
- That it is fully guaranteed
- That a complete stock of spare components is maintained throughout the United States
- That factory trained British Industries service facilities insure years of excellent performance and your continued satisfaction.

A Cordial Invitation
to visit us at the
Audio Fair in Los Angeles
February 5th, 6th, 7th.
Rooms 615 and 618
Hotel Alexandria



Whether you are a "user" or a "seller" of sound or electronic equipment, we believe you will find British Industries literature interesting, informative and valuable. Mail this convenient coupon today. ▶

BRITISH INDUSTRIES CORPORATION
164 Duane Street, New York 13, N. Y.



GARRARD
WORLD'S FINEST
3-SPEED AUTOMATIC
RECORD PLAYERS

LEAK
"POINT ONE"
AUDIO AMPLIFIER
AND PRE-AMPLIFIER
with the unique Vari-
Slope-Distortion 0.1%!

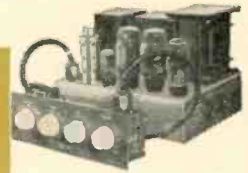

WHARFEDALE
LOUDSPEAKERS
Designed and built under
direction of world-
renowned engineer G. A.
Briggs

KT66 POWER
AMPLIFYING TUBE
"FINEST AUDIO TUBE
EVER MADE"
(Interchangeable with
American 6L6)



R-J SPEAKER
ENCLOSURES
"MAXIMUM BASS
MINIMUM SPACE"
(Manufactured in U.S.A.)

ERSIN
MULTICORE
3-CORE SOLDER
The only solder made
with non-corrosive, extra-
active Ersin resin Flux!

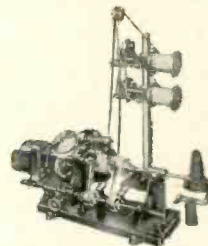

AVO
"DOUGLAS" &
"MACADIE"
COIL WINDERS
Outstanding for rugged-
ness and versatility

Other Quality British Products, which have found wide acceptance in America through B.I.C.:

SELENIUM RECTIFIERS
GERMANIUM DIODES
EXPANDED ALUMINUM MESH

British Industries Corporation Dept. A-1
164 Duane Street
New York 13, N. Y.

Gentlemen:

Please send illustrated literature to:

Name.....

Address.....

City.....Zone.....State.....



"It's SONODYNE

MULTI-IMPEDANCE DYNAMIC MICROPHONE

at recording time!"

—say actual users* in the field
and here are a few reasons why ...



"This microphone has been used for a variety of purposes—but mostly for tape recording fifteen-minute shows for future airing on a nearby radio station. We like it fine, and it does take a beating."
*Speech and Drama Director
Indiana*



"A wonderful little mike. Plenty of gain and normal voice."
*Director of Radio Activities
Texas*



"We are using this microphone with good results on our recorder."
Audio-Visual Librarian



"Wonderful for wire recording purposes and P.A. use. I use it mainly for recording."
Sound Service Massachusetts



"Used for recording organ music. Performance is very satisfactory; especially good on highs."
*Recording Professional
Colorado*



"Very good output and fidelity. Used for recording for broadcast purposes."
*Producer and Director
Canada*



"Excellent results in recording and for comments in the showing of motion pictures."
*Amateur
New York*

* Individual names available on request.

SHURE BROTHERS, Inc. — Microphones and Acoustic Devices
225 West Huron Street, Chicago 10, Illinois • Cable Address: SHUREMICRO

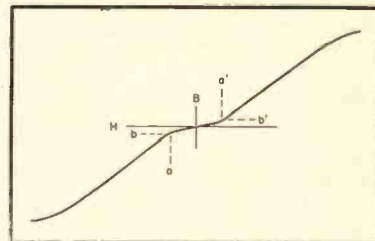

Figure 3.

According to Connell's method, a voltage is added to the signal before it reaches the head. This voltage always has the same instantaneous polarity as the signal voltage and a constant value equal to the distance from the baseline to the beginning of the linear portion of the curve.

Figure 4 shows what this is like. At (A) we see a typical audio wave during the course of a program. All the sounds being recorded are, of course, resolved electrically into a single complex waveform, which is shown.

At (B) there appears the waveform of the specially added voltage, corresponding in phase or polarity to that of the signal in each portion of the signal cycle, but having a fixed peak value. (C) shows the two mixed. The audio signal appears above and below the bracketed dotted lines. The audio never reaches zero. In effect the audio waveforms are plotted with two baselines, one for positive and one for negative alternations. The real baseline—equivalent to zero value of *H* in Fig. 3—is not reached except by the superimposed voltage in passing through it to change polarity.

The wave at (C) is applied to the recording head and thence to the tape as magnetizing force *H*. The audio modulation is always beyond the *a-a'* points of the *H* values; thus the magnetization of the tape is always beyond the *b-b'* points or on the linear portions. In this way the audio modulation on the tape is split into two separate but linear portions. The idea seems a little like drinking some bitter medicine in the middle of a meal so fast in relation to your normal eating speed that, practically speaking, the bitter taste did not exist.

The block diagram of Fig. 1 shows how the job is done. Signal is applied to one grid of a mixer stage and thence to the output stage and recording head in the usual way. It is also applied to a special clipper network. The first amplifier is a high-gain stage feeding a biased rectifier through a limiting resistor. The top-flattened signal goes through a second high-

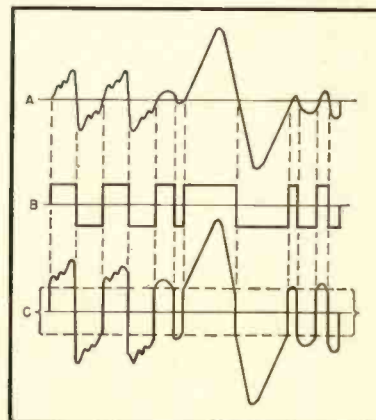
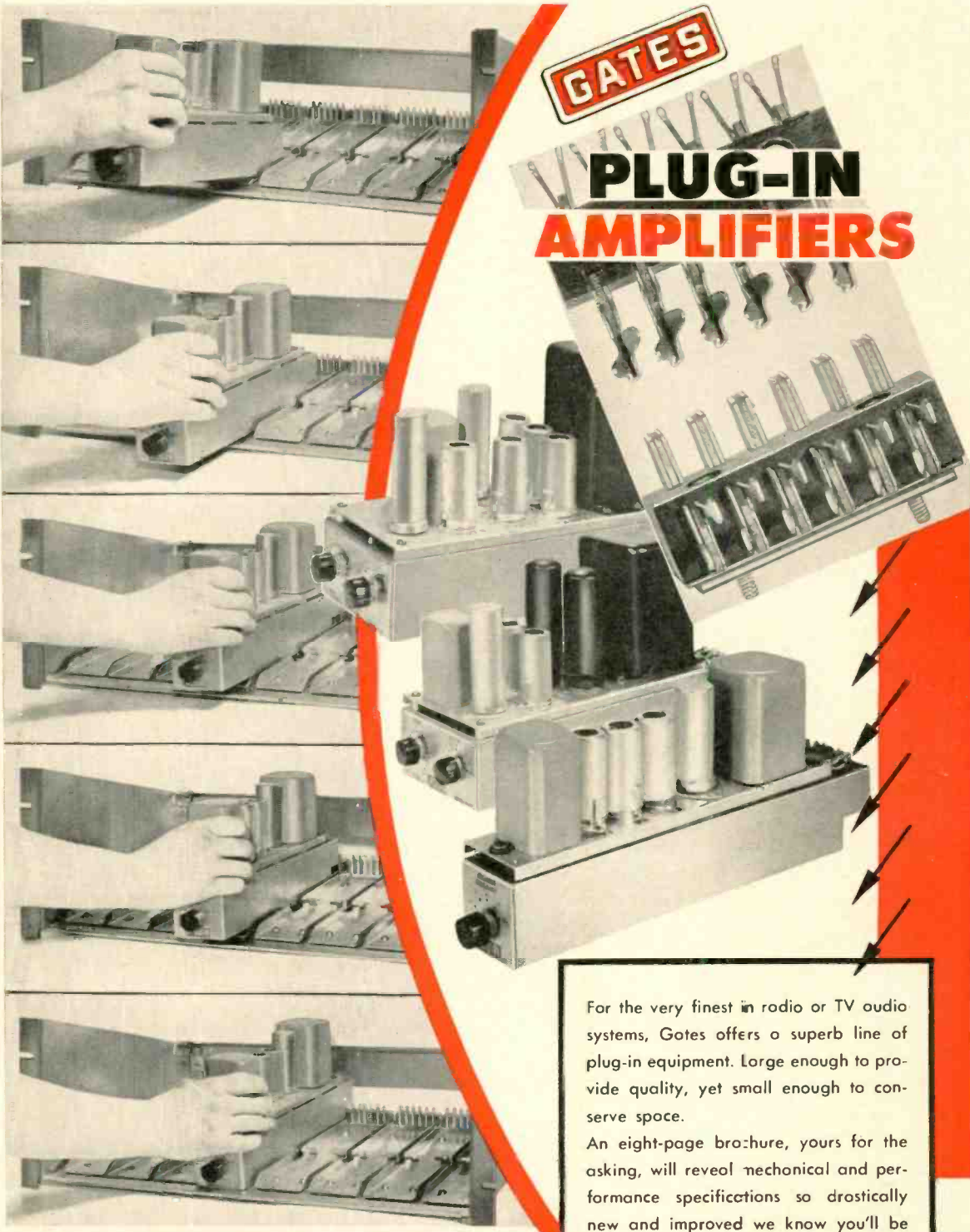

Figure 4.



GATES

PLUG-IN AMPLIFIERS



For the very finest in radio or TV audio systems, Gates offers a superb line of plug-in equipment. Large enough to provide quality, yet small enough to conserve space.

An eight-page brochure, yours for the asking, will reveal mechanical and performance specifications so drastically new and improved we know you'll be interested. Write or wire any Gates office listed below.

GATES RADIO COMPANY
QUINCY, ILLINOIS U. S. A.

13 East 40th St., New York, N. Y.
2700 Park Ave., Houston, Texas
Warner Bldg., Washington, D. C.

to the
**ELECTRICAL
ENGINEER**

or
PHYSICIST

with experience in

RADAR

or
ELECTRONICS

Hughes Research and Development Laboratories, one of the nation's leading electronics organizations, are now creating a number of new openings in an important phase of their operations.

Here is what one of these positions offers you:

THE COMPANY

Hughes Research and Development Laboratories, located in Southern California, are presently engaged in the development and production of advanced radar systems, electronic computers and guided missiles.

THE NEW OPENINGS

The positions are for men who will serve as technical advisors to government agencies and companies purchasing Hughes equipment—also as technical consultants with engineers of other companies working on associated equipment. Your specific job would be essentially to help insure successful operation of Hughes equipment in the field.

THE TRAINING

On joining our organization, you will work in the Laboratories for several months to become thoroughly familiar with the equipment which you will later help users to understand and properly employ. If you have already had radar or electronics experience, you will find this knowledge helpful in your new work.

WHERE YOU WORK

After your period of training—at full pay—you may (1) remain with the Laboratories in Southern California in an instructive or administrative capacity, (2) become the Hughes representative at a company where our equipment is being installed, or (3) be the

Hughes representative at a military base in this country or overseas (single men only). Compensation is made for traveling and moving household effects, and married men keep their families with them at all times.

YOUR FUTURE

In one of these positions you will gain all-around experience that will increase your value to our organization as it further expands in the field of electronics. The next few years are certain to see large-scale commercial employment of electronic systems. Your training in and familiarity with the most advanced electronic techniques now will qualify you for even more important future positions.

How to apply:

HUGHES

**RESEARCH AND
DEVELOPMENT LABORATORIES**

*Engineering Personnel Department
Culver City,
Los Angeles County, California*

If you are under thirty-five years of age, and if you have an E.E. or Physics degree, write to the Laboratories, giving resumé of your experience.

Assurance is required that relocation of the applicant will not cause disruption of an urgent military project.

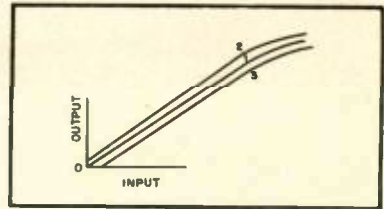

Figure 5.

gain amplifier, limiting resistor, and rectifier, followed by a voltage divider, from which it emerges as a substantially square pulse. Because of circuit arrangement it has the same phase as the original signal and because of the high amplification and clipping its peak voltage is practically constant. This is shown in (B) of Fig. 4.

It is mixed with the original audio signal in the mixer tube and the resultant is fed to an output stage and head in the normal way.

Figure 2 shows a circuit arrangement for the purpose. Input signal goes to the grid of a 6SF5 and also directly to grid No. 3 of a 6L7 mixer. The 6SF5's and 6H6's are arranged as indicated in Fig. 1, the clipper system ending in the 0.5 meg potentiometer, the arm of which is connected to grid No. 1 of the 6L7. The potentiometer is used to control the level of the "bias" voltage so that it just a little more than eliminates the hysteresis step in the B-H curve.

The 6H6's do all the clipping. They are biased by the battery or some other d.c. source so that they always clip at the same value. The 6SF5's are operated as non-distorting amplifiers so that even for a very small audio input signal the desired "bias" pulse will be created at the output.

The system may be calibrated for optimum "bias" value with a vacuum-tube voltmeter connected to each of the two 6L7 signal grids. A random adjustment of the voltage divider is made, with a constant tone being fed to the system. Then a recording is made with various values of signal voltage, the levels of each being read

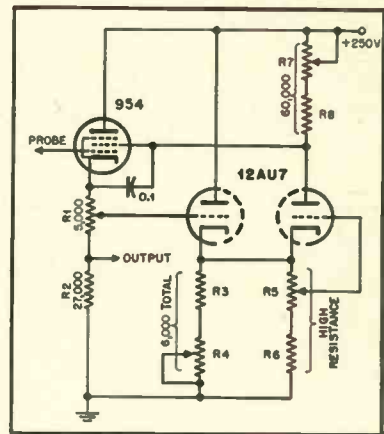

Figure 6.

on the meter connected to grid No. 3. The recording is played back and a curve is made to show audio input vs. audio output. The lower portion of the curve should have a relatively straight portion like those in Fig. 5. The object is to place the curve so that extrapolation of the straight portion will make it pass through the zero point as does curve 1. If the 0.5-meg potentiometer is set too high the results will be as in

[Continued on page 51]

Columbia Records, Inc. uses "Scotch" Magnetic Tape for its toughest recording jobs!



THE HIGHEST RECORDING STANDARDS in the industry call for the finest recording material available . . . that's why "Scotch" Magnetic Tape is used for the exacting original recordings of Columbia Master-

works. Music lovers everywhere look to these superb recordings for true, lifelike performances by the world's great artists. "Scotch" Magnetic Tape assures matchless quality of reproduction.

► *Here's why the nation's top recording engineers use more "Scotch" Magnetic Tape than all other brands combined*

- Lower noise level than any other tape
- Greater output sensitivity than any other tape
- Better reel-to-reel uniformity than any other tape
- Erases cleaner than any other tape
- No curling or cupping — always lies flat on head
- Lubricated for longer head life



The term "SCOTCH" and the plaid design are registered trademarks for Sound Recording Tape made in U.S.A. by Minnesota Mining & Mfg. Co., St. Paul 6, Minn.—also makers of "Scotch" Brand Pressure-Sensitive Tapes, "Underseal" Rubberized Coating, "Scotchlite" Reflective Sheeting, "Safety-Walk" Non-Slip Surfacing, "3M" Abrasives, "3M" Adhesives. Gen. Export: 122 E. 42d St., New York 17, N.Y. In Canada: London, Ont., Can. © The exclusive trademark of Columbia Long Playing Records—symbol of highest quality. Trade-Marks "Columbia," "Masterworks," "3M," "Reg. U.S. Pat. Off. Marcas Registradas.

here's

absolute reliability

**for heavy duty
audio
amplification**

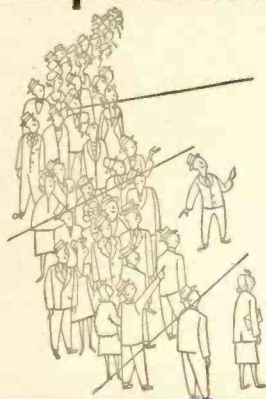

TUNG-SOL



**BEAM
POWER
AMPLIFIER**

If you've been looking for an audio output tube that's stable under the most severe conditions—completely dependable—then this is it! The Tung-Sol 5881 is rugged both mechanically and electrically—and directly interchangeable with the 6L6.

In creating the 5881, Tung-Sol engineers have made lavish use of the design and production techniques which have proved themselves over the past fifteen years—zirconium coating over the carbonized metal plate and pure barium getter to effectively absorb gas for the life of the tube—gold plated wire to minimize grid emission. These are but a few of the major design improvements in the 5881.

Tung-Sol produces the 5881 under laboratory conditions, to assure peak efficiency and maximum uniformity. You'll find this tube has the stuff to take the whole range of audio service requirements from protracted standby periods to repeated heavy overloads. So, if absolute reliability is essential in your audio circuits, the Tung-Sol 5881 is a "must." Order it from your regular supplier.

Write for characteristics and performance data

TUNG-SOL ELECTRIC INC., NEWARK 4, N. J.

Sales Offices: Atlanta • Chicago • Culver City (Calif.)
Dallas • Denver • Detroit • Newark

Tung-Sol makes All-Glass Sealed Beam Lamps, Miniature Lamps, Signal Flashers, Picture Tubes, Radio, TV and Special Purpose Electron Tubes.

LETTERS

Why Stereophonic or Binaural Reproduction?

Sir:

The most sought-after characteristic of music reproducing systems today is realism, which means the congruence of reproduced music with the original in all of its ramifications, some of which are loudness, frequency response, and spatial distribution. There is the assumption that such a congruence is both desirable and necessary. Why?

The purpose of any musical device is to produce sounds which are pleasing. It so happens that violins, pianos, clarinets, etc., when competently manipulated by composer and artist can be made to produce pleasant effects which we call music. There is nothing sacred about these instruments—they are merely the means to an end. They are generally unwieldy means, requiring infinite patience and practice to achieve pleasant results. They are tolerated only because the music can be obtained in no better way. There are many inflexible individuals who ascribe a certain sanctity to things as they are; unable to understand real or potential changes for the better. Witness the complaints that the harpsichord should not be amplified because it is essentially a weak instrument, and things-as-they-are would lose their intrinsic balance. Since there is no immediately obvious way of making it louder of itself, then it must be forbidden to do so electronically. Also can be cited the question of opera in English; because the librettist wrote for an Italian or French audience, it has been anathema to translate freely into the language which can be understood. At the same time, there is no need to go overboard for change just for the sake of change. We want to change only if there is an advantage in doing so.

The fact that musical instruments must be of finite size to produce their sounds makes it imperative that an assemblage of instruments occupy a space in proportion to their number. As a result of this "accident," any number of methods have been devised to group the members of the aggregation in a compact and aurally balanced manner. The louder percussion instruments are to the rear; the weaker instruments are usually to the front; the arrangement is often amphitheater style. "Chamber" groups are not spread out on a stage, even if it is available. They cluster together, often facing one another, and just far enough apart not to interfere with each other's movements. Desirable auditoriums are those in which reflective but non-selective reinforcement occurs—the sound floods over the audience from the walls and ceiling.

A disagreement of long standing has been that of mike placement—close-to or remote. The argument for remote placement is that a mike in the hall would "hear" the music the same way as a listener in the same location—as though it were necessary to hear the music like a live attendee. If the acoustics were ideal, he might hear the music in a fairly satisfying manner. With several mikes scattered throughout the orchestra, and with balance then maintained electronically, the most annoying consequences of instrument size are obviated. The instruments no longer have to be spread out. The result can be ideal in that each instrument would effectively be right under the baton, and its loudness would effectively be the proper loudness. Another advantage is that instruments previously discarded because of their weakness could be reinstated. The harpsichord and the recorder—to mention two which gave way to the piano and flute despite the very rich tones of the originals—are not very appropriate instruments for "live" performances. The ratio of listeners to "canned" music to those of live music being as large as it is (and even larger when the incredible number of dilettantes are weeded from the latter) makes it apparent that the needs of the home listener should come first. Fortunately, some of the recording companies are recognizing this need.

Spatial (binaural and stereophonic) reproduction must come in for some questioning if these views are accepted. Theater organs are enormous structures, and have to be split up, parts on opposite ends of the stage. Because of this, must the home listener be subjected to the same kind of disparity? It is true that spatial systems will increase the realism by recreating, to some extent, the original spatial distribution of the source. Does this aspect of realism enhance the enjoyment of music? To accomplish this with the advocated stereophonic devices there must be a symmetrical room with fairly complete damping all around. The listener has little freedom of movement of sitting position and speaker placement is rather critical. Echoes and reverberation will destroy the effect. Only the echoes of the original room are desired. For some reason the echoes which occur in the home are dirty and much to be avoided. They reduce what remains of spatial effect after concert hall reverberation has done its work.

It is admitted that stereophonic or binaural systems are ingenious. But because a system is ingenious, represents creative achievement, and works well is not sufficient reason for its adop-

another **SOUNDCRAFT** first

45 r.p.m. DISCS for recording!

Now — for the first time ever — you can offer your customers high fidelity, made-to-order 45 R.P.M. recording blanks. A triumph of Soundcraft engineering!



No special equipment needed!

The Soundcraft 45 R.P.M. recording blank will fit your conventional spindle. Whether you want to record a wedding, a home orchestra — or any other special request — the "45" gives wonderful results, and is easy to handle. Then, with the center out, it neatly fits 45 R.P.M. players.

It's ready for consumer playbacks!

With the center hole removed, place the newly recorded "45" on your 45 R.P.M. record player, and you have a high fidelity, fine quality disc. That's all there is to making a perfect professional cut!



Just remove and insert

When your recording is made, just push out the center circle, and the record is ready for the wider,

45 R.P.M. spindle. **Important note:** like conventional "45's," the Soundcraft disc is specially milled down in the center, to insure perfect operation.

All Soundcraft discs are unsurpassed for fidelity . . . for quality

Money can't buy a finer disc! With a base of the world's finest aluminum, polished to a mirror finish, and specially treated . . . coated with Soundcraft's own scientifically formulated lacquer that has been filtered 25 times purer than city drinking water . . . prepared in a sealed, triply air-conditioned, dust-free plant . . . inspected for every possible flaw . . . Soundcraft discs give you smooth, trouble-free recording . . . give your customers the ultimate in satisfaction.

Shoot for greater profits with a SOUNDCRAFT "45"!

Write for complete information to:

REEVES

SOUNDCRAFT CORP.

10 East 52nd Street, N. Y. 22, N. Y.



you'll want this
new guide to
the world's
toughest
transformers

Send for
the new



TRANSFORMER AND
FILTER REACTOR CATALOG

easier to use, more complete than ever

You'll find more than 500 units listed in the new CHICAGO Catalog transformers for every application . . . presented in one complete, easy-to-use specification guide, covering the following categories:

- MIL-T-27 Hermetically-Sealed Transformers
- New Equipment Transformers
- Television Replacement Transformers
- General Replacement Transformers
- Control & Power Circuit Transformers

You'll want this new CHICAGO Catalog for handy reference. It provides a wealth of terse factual information on CHICAGO Transformers for original or replacement use in the radio, electronic, electrical, aeronautical, geophysical, and automotive industries. Use this Catalog as your buying guide to the World's Toughest Transformers . . . depend on your CHICAGO distributor for prompt, efficient service.

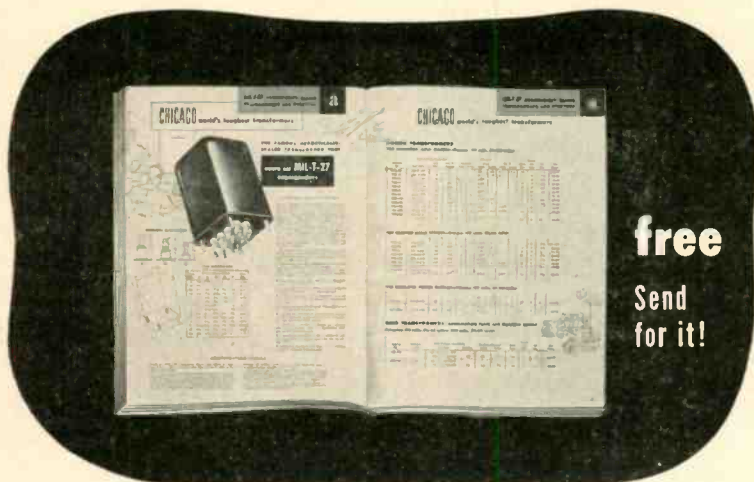

free
Send
for it!

CHICAGO TRANSFORMER
DIVISION OF ESSEX WIRE CORPORATION
3501 W. Addison Street • Chicago 18, Illinois

tion. We all know high-fidelity people who play all kinds of peculiar sound effects and bizarre music but who never, by their behavior, indicate any interest in music.

We know, too, of the frustration occasioned by the perplexed layman who is just unable to be impressed with the differences between his console and our super-four-way corner monoliths.

Much is to be said for a spatial system, however, in the case of radio drama. One of the great superiorities of TV plays over those on radio is the localization information of the former. Realism is desired and can be achieved by reintroducing the spatial dimension. Footsteps move across the room, a car pulls up at the left, a door opens on the right, and so on. However, there is little market for canned drama, and the likelihood of two-channel radio networks is slim.

There are numerous "reasons" for coaxial mounting of woofers and tweeters—the foremost being the desire to avoid a split source and interference. Despite the fact that ordinary homes are so live that the effect of standing waves at least equals these unwanted effects from the speaker, these are fairly important considerations. Few people are brave enough to mount woofer at one end of the room and tweeter at the other in an attempt to achieve a certain degree of spatiality. But when we put two speakers in the room, each fed from a different channel, where do all our worries about disparate sources and interference go? It cannot be claimed that the two speakers do not interfere because they are emitting something different. This would be much more true for the woofer-tweeter combination than for the spatial system. The truth is that localization is accomplished because of subtle intensity and phase differences at the ears, and unless the over-all system (including reverberation) is arranged so these special conditions are maintained, the results will either be of separated sources, or of an essentially diffuse and undifferentiable source.

The diffuse source approximates more closely the concert hall which has good acoustics than does the point source, and perhaps more so than does the two-channel system. The diffuse system—one which employs two or more speakers on one channel—is obviously simpler, cheaper, and not limited in program material as is the spatial system which relies on two complete and independent systems, special tape and tape playback mechanisms, or special discs and tone arms. Is it uncomfortable to recall the reluctant realization that music so often sounds better in other parts of the house (despite all the concern about tweeter beam-width) than in the same room with the speaker?

JOHN VERSACE,
5621 Georgia Ave. N.W.,
Washington 11, D. C.

(Even with a few parts eliminated to fit it in this space, this letter is long. However, the thinking seems to be worth passing along to all of *Æ*'s readers. Ed.)

Other Reactions

Sir:

While I have not seen the following idea mentioned previously, it may only be that it is too obvious to some.

Are we not trying to achieve a goal which is just about at the end of the rainbow? The job a hi-fi system is asked to do—i.e., to make the listener feel that either the original sound source is in his living room or that he is actually at the location of the original sound source—is just about psychologically impossible. Try-



in this room...

**there's
no room
for doubt**

There can be no room for doubt in the continuity and fidelity of your broadcast. Precisely the reason you demand—and get—the best in transmitting and studio equipment.

Nor should you compromise with quality in the tape recorder you select.

In AMPEX Recorders you will find the same matchless reliability and performance you expect of your transmission equipment... and for the same reason—they are engineered to the highest professional standards.



AMPEX

brings you these cost-saving operating advantages:

● **UNINTERRUPTED SERVICE**

Under the demand of heavy-duty programming, AMPEX Recorders deliver thousands of hours of unbroken service. Recently a set of AMPEX heads was returned from Honolulu for routine replacement after 11,000 hours continuous use, 17 hours a day. The heads were still within AMPEX specifications for new heads and had several thousand more hours of use remaining.

● **MINIMUM "DOWN TIME"**

AMPEX Recorders are designed for thousands of hours of continuous operation with minimum "down time," resulting in low maintenance costs and protection from sudden broadcast failures.

● **ACCURATE TIMING**

AMPEX split-second timing accuracy protects your programs and commercials from embarrassing time overlaps.

● **HIGHEST FIDELITY**

Even when programs are repeatedly transcribed from one tape to another, there is no noticeable build-up of noise level, "wow" or distortion.

● **LONG LIFE**

AMPEX Recorders are designed and built for years of service dependability. Its recordings match established NARTB standards. When you have an AMPEX, you have a machine built for years-ahead performance.



IF YOU PLAN FOR TOMORROW, BUY AN AMPEX TODAY

AMPEX

MAGNETIC RECORDERS

AMPEX ELECTRIC CORPORATION
934 CHARTER STREET • REDWOOD CITY, CALIF.

YOUR POSITIVE ANSWER

Perfect Precision Prints

**MECHANICAL MEMORY . . .
AUTOMATIC CONTROL
. . . NO NOTCHING**

Each individual film has its own Printing Control Strip, which determines printing exposures, filter changes (for color) and effects, and stores up this knowledge for transfer to the printing machine itself. This Control Strip permits exact duplication at any time.



YOUR ASSURANCE OF BETTER 16_{mm} PRINTS

15 Years Research and Specialization in every phase of 16mm processing, visual and aural. So organized and equipped that all Precision jobs are of the highest quality.

Individual Attention is given each film, each reel, each scene, each frame — through every phase of the complex business of processing — assuring you of the very best results.

Our Advanced Methods and our constant checking and adoption of up-to-the-minute techniques, plus new engineering principles and special machinery

Precision Film Laboratories — a division of J. A. Maurer, Inc., has 14 years of specialization in the 16mm field, consistently meets the latest demands for higher quality and speed.

enable us to offer service unequalled anywhere!

Newest Facilities in the 16mm field are available to customers of Precision, including the most modern applications of electronics, chemistry, physics, optics, sensitometry and densitometry—including exclusive Maurer-designed equipment—your guarantee that only the *best* is yours at Precision!



ing to make a listener believe something he knows is not so is difficult, whereas if he believes that what he is going to hear is real, a very poor reproducing system is all that is necessary to uphold the illusion. For example, vocalists with the best dance orchestras nearly always use relatively poor p.a. systems, yet it never dawns on a high percentage of the listeners at the dance that they do not hear the real live vocalist at all. The original source is nearly always completely masked by the reproducing system. I am convinced that if an audience were assembled in an auditorium in which high-fidelity speakers were placed along the front of the stage and an orchestra placed behind an opaque but acoustically transparent screen to produce the music unknown to the audience, a high percentage of this audience would report that the high-fidelity system is good but still does not quite sound real.

I do not mean to imply that we should stop trying to improve high-fi systems, but merely make the suggestion that perhaps we should re-evaluate the state of the art in this light. Maybe some who are becoming neurotic trying to make their systems sound real will be somewhat consoled. Most of the present-day systems sound fairly good to me, but no matter how good they sound, I cannot sit in my living room, close my eyes and be transferred by magic carpet to the symphony auditorium, nor does the magic carpet take me back to my living room when I see a vocalist but hear only a relatively inferior public address system.

THOMAS O. DIXON
Head, Instrumentation Division
Sound Division, Code 4006
Naval Research Laboratory
Washington 25, D. C.

ORFEO'S NEW MUSIC STUDIO

High-fidelity grown up—might well be the name for the new sound studios opened on November 19th at 19 E. 48th St., New York, for it has introduced a new method of merchandising audio to the customer. Under the direction of Ben Pinz, Orfeo has built two demonstration rooms which



are devoid of bare equipment, and which duplicate typical home environments—one modern and the other in traditional decor.

Planned for the Aunt Minnie type of buyer, Orfeo offers a normal living-room arrangement with several "package" systems suitably cabinetted, and working as complete units so the non-technical listener may judge performance and can see for himself just how high-quality sound reproduction would fit into his own home. Orfeo's services include complete decoration and acoustical treatment when required, bringing the knowledge of the custom builder and the talents of the decorator together in a unique and workable combination.

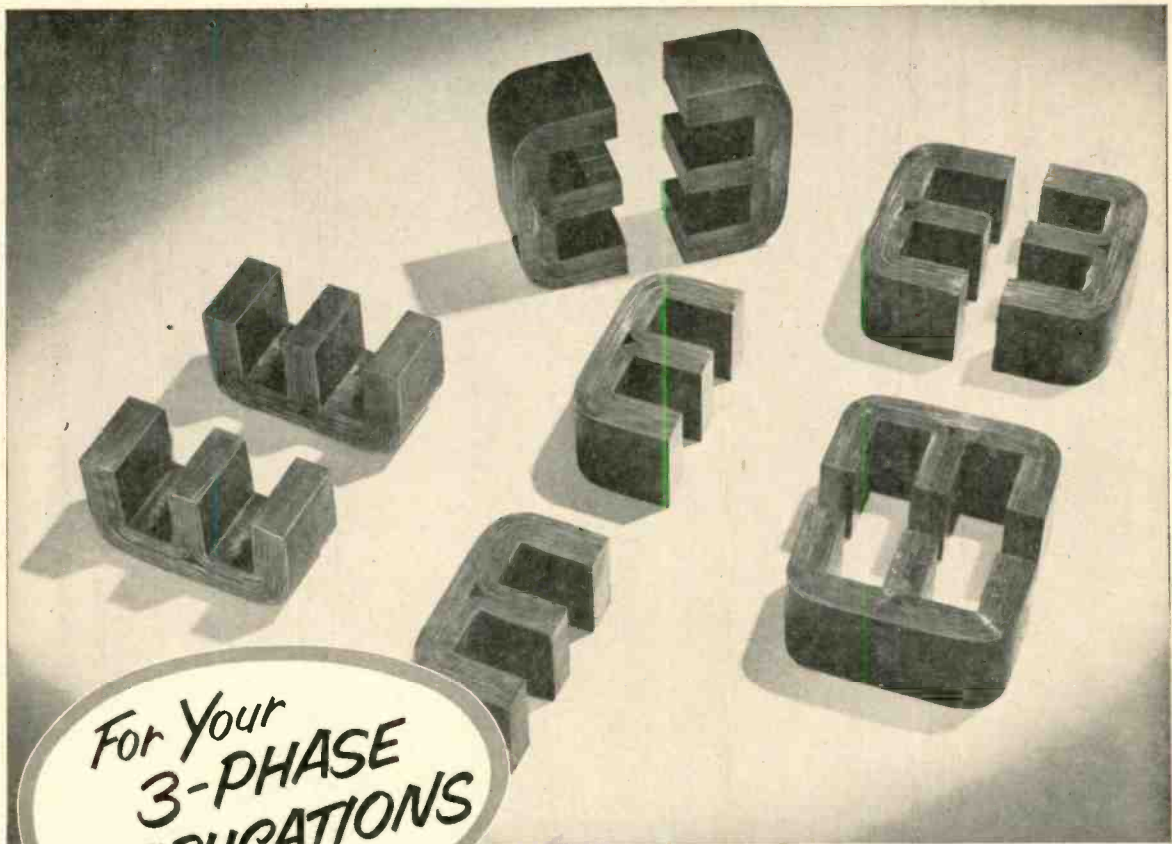

For Your
3-PHASE
APPLICATIONS

Arnold E-CORES

made from SILECTRON strip
(*grain-oriented silicon steel*)

The use of "E" cores, wound from grain-oriented silicon steel, results in weight and size reduction as well as higher efficiency and possible cost savings. "E" cores can be supplied in a variety of window sizes and core areas from 1, 2, 4 or 12-mil Silectron strip, for high or low frequency 3-phase applications. • All Arnold cores are made by precision methods, and carefully tested under closely controlled conditions to assure highest quality and reliability. *We'll welcome your inquiries.*

W&D 4437

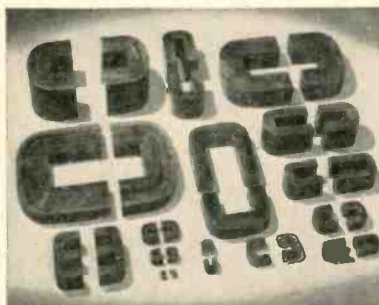

C-Cores to meet any requirement

For your single-phase applications, Arnold "C"-Cores are available in any shape and quantity, and in any size from fractions of an ounce to hundreds of pounds . . . wound from Silectron strip in a wide range of ultra-thin and heavier gauges.

THE ARNOLD ENGINEERING COMPANY



SUBSIDIARY OF ALLEGHENY LUDLUM STEEL CORPORATION

General Office & Plant: Marengo, Illinois

SOLVE your hi-fidelity problems with
University
CONE
SPEAKERS
-HIGHEST QUALITY!
-LOWEST COST!

MODEL 6201 — COAXIAL SPEAKER SYSTEM. Now generally acknowledged to be industry's finest value in a high quality 12" speaker. TRUE coaxial dual range system comprising clean sounding woofer with heavy exclusive Alnico 5W magnet, DRIVER TYPE tweeter with "Reciprocating flares" wide angle horn, and BUILT-IN crossover network complete with "Balance" control.

DIFFUSICONE-12 — WIDE RANGE WIDE ANGLE 12" SPEAKER. Exclusive "diffusicone" design utilizes the benefits of dual-horn loading, radial protection and diffraction principles to achieve unsurpassed quality and sound distribution from a single unit speaker. Enjoy full fidelity ANYWHERE. In the room . . . at a surprisingly reasonable cost.

DIFFUSICONE-8 — WIDE ANGLE 8" SPEAKER. Same as the Diffusicone-12 except in 8" size. Remarkable fidelity and exceptional sensitivity and power handling capacity make this a truly outstanding eight. Ideal for use where space is limited, and is also a perfect selection for a mid-range speaker in 3-way systems.

MODEL 6200—EXTENDED RANGE 12" SPEAKER. Designed for general applications, capable of highly efficient FULL-BODIED response throughout the operating spectrum. May be used with equal facility to improve commercial radio, TV, phone sets, high quality sound re-inforcement in night clubs, churches, schools, etc., or as a woofer. The 6200 must be heard to be appreciated.

MODEL C-15W—DUAL IMPEDANCE RANGE 15" WOOFER. Brand new low frequency reproducer embodying many exclusive advance features. Its superior response and acoustic output is due, in part, to a newly University-developed cone and voice coil suspension system permitting the greatest axial movement ever achieved. The incredibly low distortion results from a new magnet assembly.

There is a UNIVERSITY Tweeter for every application and pocketbook. Write for descriptive illustrated literature. Address Desk A-1

University
LOUDSPEAKERS INC
 80 SO. KENSICO AVE., WHITE PLAINS, N. Y.

Binaural Radio Broadcasting

HAROLD T. SHERMAN*

History and prospects of a new step in the search for optimum realism in sound reproduction.

AS TIME MARCHES ON, new developments in audio play an important part in relaying by radio greater realism through a feeling of presence. One of the earliest attempts to transmit this feeling of presence was by means of a dual telephone circuit, using one circuit for each ear, between the Paris Opera House and the Paris Electrical Exhibition in 1881. Binaural broadcasting has demonstrated that the listening audience outside the studio can enjoy the program with less listening effort and less aural fatigue.

A brief history on the subject of binaural broadcasting reveals that the interest of engineers and experimenters was sparked off in the very early 1920's when radio broadcasting was just beginning. At that time the limitations of the audio components used for converting speech and music in the studio into realistic sound in the home created the need for radical changes in sound reproduction methods. In those days the parlor stereoscope with pictures produced by a stereo (binocular) camera were well known for their ability to give us third-dimensional visual reproduction.

Radio fans around New Haven, Connecticut, were probably the first to hear the results of binaural broadcasting. F. M. Doolittle, Professor of Electrical Engineering at Yale University, pioneered this radio system and applied for U. S. patents in 1921. He had articles published in *Electrical World*, and in the radio section of the *New York Herald Tribune* in 1925, giving general information on his findings, with a description and photographs of Station WPAJ, which operated binaurally during 1925. WPAJ used two 50-watt AM transmitters, one on 1320 kc and the other on 1110 kc. One antenna was excited by both transmitters whose antenna coils were connected in parallel.

During this same period, KDKA in Pittsburgh also used Mr. Doolittle's system experimentally and eventually bought his patents. Unfortunately the crowding of the AM band of frequencies made it impractical to continue, or expand, binaural radio at that early period.

In the early 1930's, Bell Telephone Laboratories gave several technical demonstrations of their research on stereophonic sound reproduction for motion pictures. These demonstrations, given to the AIEE, the Acoustical Society of America, and other engineering groups, made a deep impression of the listening advantages, but a practicable two-channel, non-interfering, radio-audio circuit was not readily available.

Present Interest Growing

Revival of development of binaural sound reproduction came when Magnecord, Inc. of Chicago, produced a special twin-track magnetic tape recorder for the Navy Department. It was demonstrated in 1951 that this unit basically was suited to record and reproduce music and sound in third dimension for special music study.

* Sherman Studio, Carnegie Hall, New York.

At the Audio Fair in Chicago in May, 1952, Magnecord, Radio Craftsmen, and Jensen cooperated with WGN (AM) and WGNB (FM) to demonstrate that binaural radio broadcasting—using the AM frequency for one channel and the FM frequency for the other channel—was a practical improvement as compared to the single or monaural system. During this binaural broadcast to several hundred hi-fi fans in the hotel ballroom, WGN received several hundred phone calls from home listeners, who for the first time had their ears effectively placed where the microphones were located in the studio. The next day WGN received scores of enthusiastic letters about the improvement in realism, as well as the apparent freedom from distortion of loudness differences. This latter effect improved definition and made it possible for each voice of the orchestra to be followed just as one can do when his two ears are in the microphone location.



Mr. Sherman

It was also discovered that a space consciousness was added to the reception, giving better judgement of the size of the studio and the number of musicians. Possibly the biggest improvement was noticed in the added directional consciousness which spread the orchestra out in the listening area at home, so that you felt the violins in their relative location to the woodwinds, brasses, drums, etc.

Orchestra conductors, choral directors, and organists find that they hear definition and tone-value balance from a listening position more normal to their audience when they review their work binaurally. Orchestras and choirs can be rehearsed by assistants or students, with a delayed reproduction creating a most accurate sound picture for critical review.

AM Used With FM

FM radio offers the logical medium for the second channel in a binaural system because of a complete non-interference with any AM transmitter frequency. Static-free reception and even better audio-frequency

[Continued on page 71]

MAURER 16mm AT WORK FOR THE JAPANESE GOVERNMENT!



Ian Mutsu, president of the International Motion Picture Company, Tokyo, makes films for the Japanese Government . . . and for United Press-Movietone TV Newsreel. What camera? The Maurer "16," of course. "Thoroughly satisfied," says Mr. Mutsu . . . as all the world's top professionals say of the Maurer "16" . . . because it meets so many varied needs, gives top performance under all conditions of light, temperature and humidity.



THE MAURER 16mm. designed specifically for professional use, equipped with precision high-power focusing and view-finder. Standard equipment includes: 235° dissolving shutter, automatic fade control, view finder, sunshade and filter holder, one 400-foot gear-driven film magazine, a 60-cycle 115-volt synchronous motor, one 8-frame handcrank, power cable and a lightweight carrying case.



THE 16mm. SOUND-ON-FILM RECORDING SYSTEM combines the highest fidelity in 16mm. recording practice with wide flexibility and extreme simplicity of operation.



THE MODEL F PRIME RECORDING OPTICAL SYSTEM AND GALVANOMETER. A complete light modulating unit for recording sound photographically upon standard film, requires no special servicing or spare parts (other than recording lamp).

maurer means *finer motion pictures!*

J. A. MAURER, INC.

37-01 31st Street, Long Island City 1, New York
1107 South Robertson Blvd., Los Angeles 35, California

**16mm
maurer**

CABLE ADDRESS:
JAMAUFER

EDITOR'S REPORT

NEW YEAR'S RESOLUTIONS

COMES THE FIRST of January and many of us have the urge to make resolutions. Like many a reader, we felt these urges, and even thought out the first few paragraphs before putting them on paper. Since they seemed somewhat familiar, we checked back to January, 1952, to make sure we were not simply repeating ourselves. Believe it or not, we found many of the same words and expressions, not to mention ideas. If *Æ* were like some magazines, that would not have been disastrous, since few readers would have had the previous January's copy to compare. But we know that a large percentage of *Æ*'s readers keep complete files, and (assuming anybody reads this page at all) they would probably remind us of the repetition. We like to think that 1952's first Report was well written, and that it contained the credo we intend always to follow. But we must admit that we have not done everything we hoped to during the last year.

One of the changes we aimed for was to attempt to enlighten the novice in our field in the technical aspects of audio. We have made some progress in that direction, but we have not done all we would have liked to. We have included much material that scarcely could be called "engineering" in an attempt to provide the maximum coverage of the entire audio field. As a result, the more technical-minded of our readers were inclined to think that there was too much "butter on the popcorn." Keeping a desirable balance between the technical and the non-technical articles is like walking a tightrope. We try to please every one of our readers, and we realize that our future depends on how well we succeed.

On the credit side, we note that in 1952 we had a total of 762 pages—both editorial and advertising—as compared to 640 in 1951, an increase of 19 per cent. This corresponds quite closely to two extra issues, since the average was 63.5 pages. For this gain, we are indebted to our advertisers, for only through their support is it possible to produce a magazine. They are responsible for the 96 and 92 page issues of October and November, and we are pleased that they have seen fit to use more of *Æ*'s pages to carry their messages to you.

And so it is, on the threshold of a new year, that we salute our advertisers. They work the year around to make their products as good as they know how, for they too have to please their customers. Without advertisers we wouldn't exist—and many of our readers would not be so well informed about the products that make their spare time interesting—the products that bring the best of sound reproduction into the homes of discerning music lovers. No matter how the program arrives in our living rooms—by AM or FM radio, by wired music systems, by light waves, or over the water pipes even—it is the program that is important. In the final count, audio equipment must be involved from the moment the original sound is created in the studio or auditorium until it is recreated in our homes. Until someone comes along with a new method of sound reproduction, audio appears to offer the best possibility.

BINAURAL OR STEREOPHONIC?

It isn't often that *Æ* devotes an entire issue to any one subject, but if any single issue can rightly be called

a special one, this is it. From the reception it had at the recent Audio Fair in New York, it would appear that the newest thing in the audio field will involve two completely separate channels—which means twice as many amplifiers, twice as many speakers, twice as many signal sources. In the studio it will involve twice as many microphones in addition to amplifiers, attenuators, loudspeakers, and all the other elements in a transmission system.

Binaural broadcasting is certain to require new techniques—one of the most important being that of microphone placement, for with the present plans which involve both AM and FM radio channels, each program must sound well by itself, since many listeners will not be equipped to reproduce both at the same time. We have not got that far in our coverage of the binaural picture yet, but it is sure to come in the next year. In any case, it is sure to give us an opportunity of comparing systems quite easily—something which many of us don't do with a single set of equipment. This swing toward binaural or stereophonic broadcasting should bring out many new developments in the next twelve months. For the present, however, we hope we have covered the field reasonably well, as evidenced by the articles on pages 14, 22, 25, and 46. We will keep informed on this subject, and will pass on all the information we receive.

SOUND REPRODUCTION COURSE

Edgar M. Villchur, who is currently authoring the series entitled "Handbook of Sound Reproduction" is beginning a new course on the subject of sound reproduction at New York University, Division of General Education. This course begins on February 4 and runs until May 20, meeting at the Washington Square center on Wednesday evenings from 7:00 to 9:45 p.m. Further information can be obtained from NYU, and registration by mail or in person begins on January 19.

TAPE RECORDING IN ICELAND

We note with interest that the proceedings of the Iceland Parliament at Reykjavik are to be preserved for future generations by means of tape recording equipment recently installed in Iceland's two chambers of parliament. With eleven Stencil-Hoffman recording units, the entire proceedings of the General Assembly's continuous debate will be recorded. We hope this practice will spread to the Western Hemisphere before many more months.

STANDARDIZATION FOR LOUSPEAKERS

It has been suggested that loudspeakers be standardized as to polarity, and be marked so that two speakers can be connected in parallel without trying to cancel each other. The proposal from one of *Æ*'s readers is that a polarizing symbol be applied to that terminal which, when fed with a positive voltage, will result in an outward cone movement. This seems simple enough, and would certainly help with horn-type tweeters, where it is nigh onto impossible to determine which way the diaphragm moves when we apply a small voltage from a battery.

"For those who can hear the difference"

Listen....

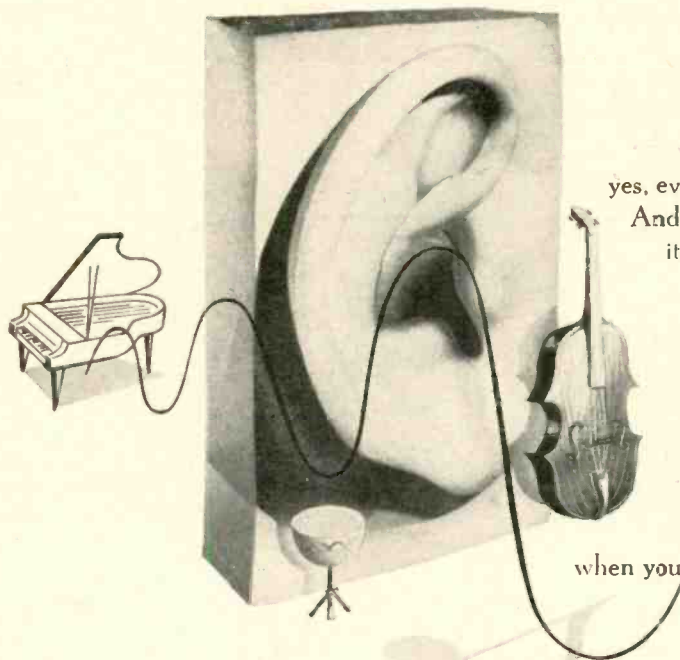

... it comes to you
in the subtle shading of a piano ...
in the clean brilliance of violins,
the purity of a flute. Your ear detects
the sweet mellowness of cellos,
the roundness of a clarinet ...
yes, even the iridescence of clashing cymbals.
And, as the symphony swells to crescendo,
its dynamic energy adds a flood of color
to your musical canvas.

For those who can hear the difference,
these are the elusive pleasures
that often remain hidden
in the grooves of fine recordings.

These are the thrilling
new listening experiences
that are released for your enjoyment
when you use quality components by Pickering.

PICKERING COMPONENTS

"for those who can hear the difference"

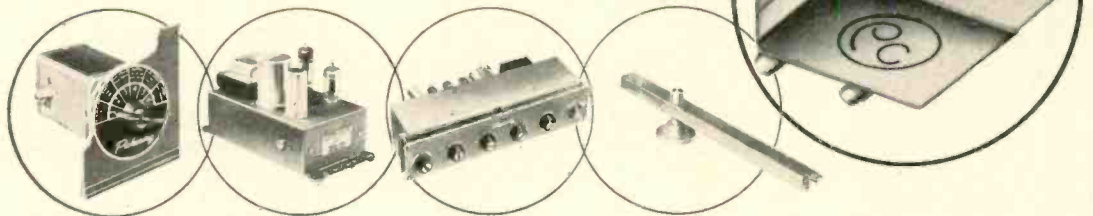

PICKERING and company, incorporated

● Pickering High Fidelity Components are
available through leading Radio Parts dis-
tributors everywhere; detailed literature
sent upon request. Address Department A 1

Oceanside, L. I., New York





These signals find the way

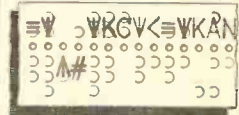

SENDING

When you dial a telephone number, high-speed switching mechanisms select your party and connect you. Through a new development of Bell Telephone Laboratories, similar mechanisms are doing the same kind of job in private wire teletypewriter systems which America's great businesses lease from the telephone company.

Company X, for example, operates an air transportation business with scores of offices all over the country. At one of these offices, a teletypewriter operator wishes to send a message, let us say, to Kansas City. Ahead of the message, she types the code letters "KC". The letters become electric signals which guide the message to its destination.

Any or all stations in a network, or any combination of stations, can be selected. Switching centers may handle 50 or more messages a minute . . . some users send 30,000 messages a day. Delivery time is a few minutes.

Defense manufacturers, automobile makers, airlines and many other American businesses are benefiting by the speed and accuracy of the new equipment — another example of how techniques developed by the Laboratories for telephone use contribute to other Bell System services as well.



RECEIVING



BELL TELEPHONE LABORATORIES

Improving telephone service for America provides careers for creative men in scientific and technical fields.

Practical Aspects of the R-J Speaker Enclosure

WILLIAM JOSEPH* and FRANK ROBBINS**

A further discussion of the enclosure which has created so much interest and which was the forerunner of the current flurry for small cabinets.

COMMERCIAL HIGH-FIDELITY reproducing equipment has for some time been available at prices low enough to permit widespread use in home installations. Tuners, amplifiers, cartridges, and speakers which can handle the range from 50 to 10,000 cps are today quite reasonably priced, and equipment handling 30 to 15,000 cps is available in the higher-price range. Speaker development has reached the stage where the former range can now be handled by single-cone speakers and the latter by two- or three-way speaker systems. Most of the progress taking place in speaker development over the last decade has been mainly in extension of the treble range, since low bass reproduction in speaker techniques preceded the development in the treble range.

Reproduction of the low bass end, however, is a function not only of the speaker but of speaker enclosure as well. As almost all 12- and 15-in. speakers designed for the high-fidelity market are capable of reproducing down to 50 cps and below, the responsibility for low bass reproduction today rests almost entirely on the enclosure. Unfortunately, space limitations in the modern home mitigate against the use of large enclosures and in most home systems the octave below 100 cps is generally missing or is strongly curtailed. While such systems would sound balanced and pleasing before the full treble range became available—and do indeed sound better if the amplifier treble control is cut back—it is generally found today that home systems are operated with the treble control flat and with the bass control considerably boosted in an attempt to improve balance. While this boost in the 100- to 200-cps range may help matters somewhat, there is actually no true bass "feeling" to such reproduction. It was considered worthwhile, therefore, to attempt to develop a small enclosure which would permit extending the bass range to at least 50 cps, and if possible to attempt to attain this result without resonant peaks, yet with good damping and transient response. Resonant peaks in the bass range produce "boom" and "barrelly" speech reproduction, while poor transient response "muddies up" the bass.

* 5218 19th Ave., Brooklyn 4, N. Y.

** 10 West 86th St., New York 24, N. Y.

A brief consideration of existing systems required to provide 50-cps response will be pertinent in tracing the development of the R-J system and the following types of speaker housings will be considered:

1. Flat Baffle
2. Open-back Box
3. Closed Box
4. Horns
5. Bass Reflex
6. The R-J Enclosure

The Flat Baffle

To reproduce 50 cps adequately, a flat baffle must be eleven feet square. If the speaker itself resonates at 50 cps, there will be a hump in pressure-response curve at this frequency and the response will fall off below this point at the rate of 18 db per octave.

The Open-Back Box

Open-back boxes are not suitable. A 7-cu. ft. open-back box 4 in. from the wall produces a walloping "boom" at 100 cps¹ and response drops off below at the rate of 18 db per octave. Below 100 cps, frequency-doubling and tripling is extremely objectionable.

Closed Boxes and Horns

Completely enclosed boxes need to be very large. A 15-in. speaker will require

¹ Daniel Plach and Philip Williams, "Loudspeaker enclosures." AUDIO ENGINEERING, July 1951.

12 to 18 cu. ft. of air, depending upon speaker compliance.

Horns provide high efficiency and good transient response. For 50 cps, the horn works out to a mouth diameter of 6 ft. 8 in., or its area equivalent, and a length of about 8 ft. This is a little bulky for use in the average home. However, Klipsch² has been able to fold the horn ingeniously so as to require only 13 cu. ft. of space.

The Bass Reflex

In pursuing small enclosure design, it was felt that the most fruitful field for investigation lay in the direction of resonating systems. A resonating column³ or chamber will produce sound with very little energy to activate it. Consequently, proper design may achieve useful sound output at some point in the register where system response would otherwise fall off. The bass-reflex enclosure⁴ is an example of this kind of system which, until recently, offered the closest approach to meeting the space problem. The typical bass-reflex enclosure shown in Fig. 1 consists of a box with a speaker mounted in it and a port hole in the front near the speaker opening. The first

² Paul W. Klipsch, "Design of compact two-horn loudspeaker." *Electronics*, Feb. 1946.

³ Benjamin J. Olney, "Acoustical labyrinth." *Electronics*, Apr. 1931.

⁴ A. L. Thuras, "Sound translating device." U. S. Patent 1869178.

Fig. 1. Typical bass-reflex cabinet, and the one used in the comparison measurements described.

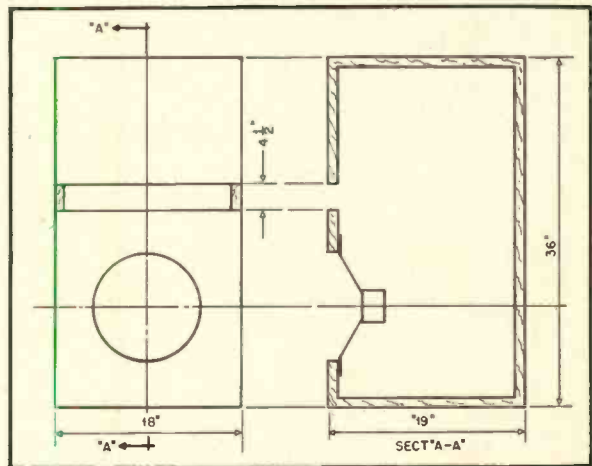

step in the design of the enclosure requires that the air resonance of the box occurs at the free-air cone resonance of the speaker.

The air resonance of the bass-reflex enclosure can be closely determined:

$$f = \frac{c(A)^{1/4}}{2\pi(V)^{1/4}} \quad (1)$$

where A = the area of the port

V = the volume of the enclosure

c = the speed of sound in air

This bass reflex cabinet, later used as a comparison enclosure, employs a 12-in. speaker with a free-air cone resonance of 63 cps. To determine the volume V required, the formula may be rearranged to read

$$V = 2070 \left[\frac{(A)^{1/4}}{f} \right]^4 \quad (2)$$

where V is in cu. in.

A is in sq. in.

f is in cycles per second.

Using A of 75 sq. in. and f of 63 cps, V comes out to be 9400 cu. in. Adding another 400 cu. in. for the speaker, the total internal volume required is 9800 cu. in. or 5.7 cu. ft.

Bass reflex enclosures must be carefully tuned after mounting the speaker to produce optimum results. Since the enclosure is generally purchased separately and the speaker mounted within it without further adjustments, it is seldom that proper results are obtained. This is one of the major drawbacks of the bass reflex. When properly tuned, a bass-reflex enclosure will exhibit two impedance peaks of equal amplitude, equally spaced in frequency above and below the speaker free-air cone resonance. The impedance curve of the comparison enclosure with a 12-in. 8-ohm speaker mounted in it is shown in Fig. 2.

Exploring the possibilities for appreciable reduction in size of the bass-reflex enclosure, it becomes evident from inspection of equations (1) and (2) that this may only be accomplished by reduction of the port area. Basically, the enclosure air resonance must occur at the free-air cone resonance of the speaker. The enclosure air resonance, being out of phase with the speaker, restricts the tendency for large movements of the speaker cone while at the same time sound radiation from the port area takes over and helps to provide acoustic output at this frequency.

If the port area is reduced, acoustic

radiation—which is proportional to the port area—drops off correspondingly and the desired sound output is not obtained. In addition, if the port area becomes too small the enclosure begins to approach closed-box performance. There is, therefore, a law of diminishing returns in operation and as a result, ports are generally compromised to about 75 per cent of the speaker area. Sometimes the further addition of a duct added to the port is employed. By this means a further small reduction in volume can be obtained.

The R-J Enclosure

In pursuing the design of a small enclosure, various types of resonant principles were explored and an adaptation of the Helmholtz resonator was finally adopted. In this type of resonator, Fig. 3, the mass of air in the opening A swings back and forth at resonance and the air in the cavity V acts as a resisting spring against the movement of the air in the opening. The combination sets up a system analogous to the weight on a spring and has a resonant frequency determined by the mass and the compliance of the arrangement. The equa-

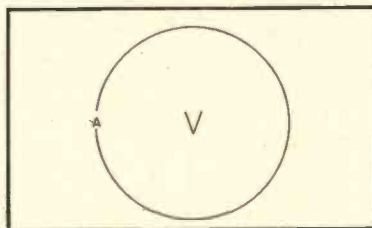

Fig. 3. Basic diagram of Helmholtz resonator.

tion for the resonant frequency of the resonator is the same as that for the bass-reflex enclosure, equation (1).

Helmholtz resonators are characterized by extremely high Q and if a speaker is placed within such a resonator the response curve will exhibit a very high peak at resonance. If, however, some means to control the Q can be incorporated into the system, a small enclosure could conceivably be designed which would permit flattening the peak. A practical form of enclosure which attains this end takes the form shown in Fig. 4.

The system still acts as a Helmholtz resonator with the further modification imposed by the creation of a duct sys-

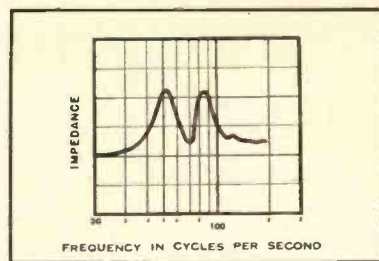

Fig. 2. Impedance curve of the speaker mounted in the cabinet of Fig. 1.

tem, indicated by arrows in the figure, between the back cavity and the frontal opening. The resonant frequency of an enclosure with a volume of 4800 cu. in. and a frontal opening of 64 sq. in. calculates out as follows:

$$f = \frac{(1080 \times 12) \times (64)^{1/4}}{2\pi(4800)^{1/4}} = 84 \text{ cps.}$$

Actually, close calculations require several refinements to take into account the effect of duct length and the end corrections.

Control of the circuit Q is obtained by varying the spacing of the duct produced between the frontal board and the speaker board. By decreasing this spacing it is possible to introduce acoustic resistance to lower the Q and increase damping. The acoustical resistance of a slot is expressed by the equation:

$$R_a = \frac{kl}{t^3w}$$

where k = a constant

l = the length of the duct passage

w = the width of the duct passage

t = the thickness of the duct passage (the spacing between the frontal board and the speaker board).

The acoustic resistance is a function of the third power of the spacing and becomes quite critical as t becomes small. Halving the spacing increases the acoustic resistance by eight times. By experimenting with the spacing it was found possible to reduce the circuit Q and broaden the resonance so that with a speaker of 63 cps free-air cone resonance, this system extends smoothly to 50 cps without any peak at resonance.

The introduction of the acoustic resistance also has a strong effect upon speaker loading. This is very desirable in improving speaker damping and the magnitude of damping obtained may be judged from the amount of lowering in frequency of speaker resonance below the free-air cone resonance. As shown in the impedance curve of Fig. 5, the speaker resonance in the R-J enclosure is 32 cps, as against 50 cps for the same speaker in the bass-reflex enclosure, Fig. 2. It is believed that a 32-cps loaded speaker resonance, as against a 63-cps free-air cone resonance, is considerably lower than can be achieved by other systems.

[Continued on page 67]

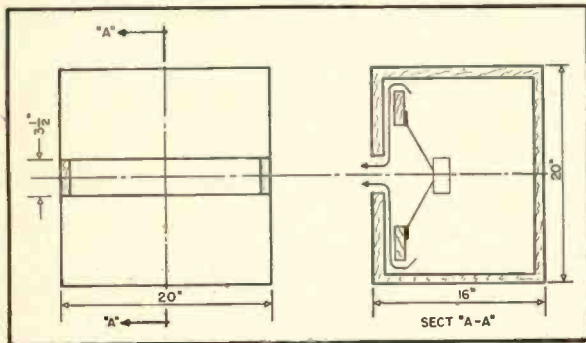

Fig. 4. Front and sectional views of R-J speaker enclosure.

Zero-Impedance Output Stage

RAYMOND G. ANTHES*

Excellent transient and low-frequency response and good loudspeaker damping make this amplifier suitable for high-quality, low-power applications.

THE ZERO-IMPEDANCE STAGE to be described was designed for home use, along with its driver, to give good quality performance at moderate cost. A series R-C circuit (R_1, C_1 in Fig. 1) shunts the primary of the output transformer so that the output tube works into almost unity power factor load. This minimizes harmonic distortion and phase shift. The feedback circuits are direct coupled and the negative voltage feedback is taken from the primary of the output transformer rather than the secondary in order to reduce undesired phase shift to a minimum in this feedback loop.

The low-frequency response is exceptionally good because the stage is effectively acting as a zero-impedance source feeding the primary of the output transformer. The output transformer used was of good quality and had 1-inch stack. A frequency response taken with the loudspeaker connected, and measuring output voltage across the secondary of the output transformer indicated the 3-db-down point was below 20 cps at the low end, and at 5000 cps at the high end, and only 9 db down at 15,000 cycles per second. At $2\frac{1}{2}$ watts output into a resistance load at 400 cps, the total r.m.s. distortion was under 5 per cent. This is relatively high by most standards, but quite low for a 6V6.

A disadvantage of taking the negative voltage feedback from the primary of the output transformer is that this feedback cannot correct for the fall-off in high-frequency response in the transformer.

* Professor of Electrical Engineering, University of Manitoba, Winnipeg, Man.

The writer prefers to sacrifice some high-frequency response for minimum phase shift in the negative feedback circuit. This assures that the feedback works most effectively, reducing intermodulation distortion to a minimum, giving maximum reduction of harmonic distortion and maintaining a low-impedance source feeding the output transformer, over and beyond the complete audio frequency spectrum. It is possible to compensate for this loss in highs by a fixed equalizer in the preamplifier, but this was not done because the high-frequency loss was not serious. Most preamplifiers incorporate some form of tone control circuit with treble boost which can be used for this equalization.

The use of the series R-C network

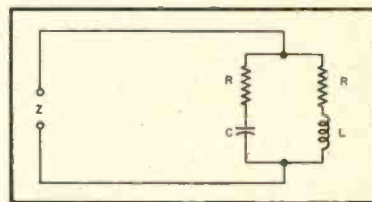
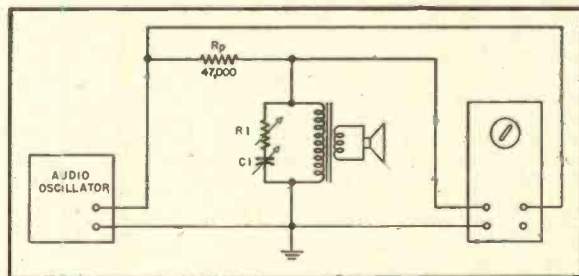

Fig. 2. Series R-C circuit and series R-L circuit in parallel.

proved that the impedance of the parallel combination will be a pure resistance equal to R at all frequencies, if $R = \sqrt{L/C}$. At frequencies above the resonant frequency of the loudspeaker, the impedance measured across the primary of the output transformer with the loud-

Fig. 3. Circuit used to determine optimum values of R_1 and C_1 of Fig. 1.



across the primary of the output transformer to provide virtually unity power factor load to the tube is not new. The theory of this is well known. If a series R-C circuit and a series R-L circuit are connected in parallel as shown in Fig. 2, where the R 's are equal, it can be

speaker load on the secondary may be roughly approximated by a series R-L circuit. Consequently, within this frequency range, which extends from approximately 125 cps to the highest audio frequencies, the composite load impedance presented to the tube is very nearly pure resistance with small variation in magnitude with frequency.

If values of R_1 and C_1 are chosen to give the optimum composite load impedance, there will be appreciable reduction in available output power at the higher frequencies where the reactance of C_1 becomes small in comparison with the magnitude of R_1 . This is a serious disadvantage. A compromise between these two factors was made in this design.

Adjustment of R and C

The effect of changing R_1 and C_1 can be observed readily on an oscilloscope by the simple circuit of Fig. 3, and the values of R_1 and C_1 were finally selected in this way. The value of R_p used was 47,000 ohms, which approximates the plate resistance of the 6V6. The phase angle of the combination is determined from the ellipse appearing on the screen.

For the tube operating voltages used, the load impedance Z presented to the tube should be from 7,000 to 10,000 ohms.

[Continued on page 66]

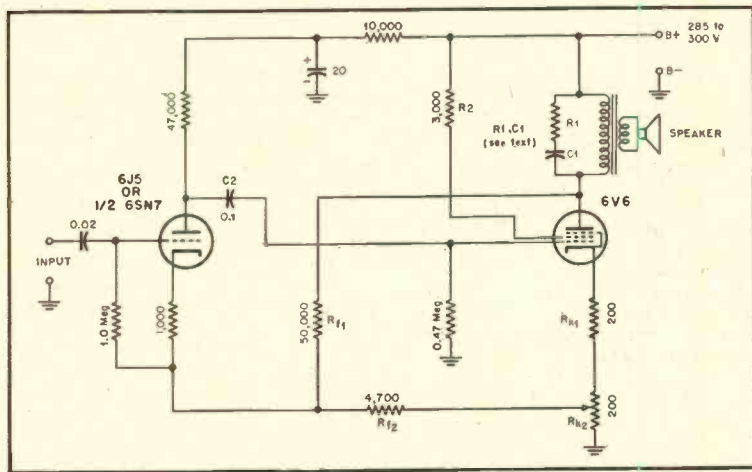

Fig. 1. Schematic of simple two-stage amplifier employing negative voltage feedback and positive current feedback to obtain an output impedance approximating zero.

Binaural or Stereophonic?

R. J. TINKHAM*

The author clarifies the meanings of the two words which have been used to describe this latest of interesting innovations in the field of sound reproduction.

SOME CONFUSION apparently still exists in the minds of many regarding the definition and connotation of the words *binaural* and *stereophonic*. Binaural means, literally, "two-eared." It refers to the fact that the sense of hearing in both ears, plus the brain, makes it possible for us to analyze sound, to discriminate against unwanted sounds and, to a large extent, to localize the source of a sound. Stereophonic, on the other hand, means "three-dimensional sound," or a sound source "in the round," much as we perceive it in actual experience. It can be stated, then, that one uses his binaural sense to perceive stereophonic impressions. This is much like saying that one uses his binocular sense of vision to achieve stereoscopic or three-dimensional impressions. If we stop up one ear with a finger when listening to someone in a noisy place, we will observe how the ability to discriminate against the background noise disappears and the ability to localize the source of sound vanishes. Or, if we shut one eye, our judgment of depth is gone and, although we know better, all objects are as on a flat surface. Compare a monocular snapshot with the modern stereophoto or, for that matter, with grandma's "Trip to Egypt" via the old-fashioned stereoscope. The difference is remarkable.

Modern tape recording has achieved, (a) an easy recording method, (b) the ability to record more than one channel at a time on the same tape, and (c) reasonable expense. It is inevitable that someone would think of trying to capture sound stereophonically. Our attention has again been directed to the Bell Labs experiments¹ of 1933 with the Philadelphia Orchestra performing at home and being reproduced in Washington with startling realism, facts lost sight of for nearly a generation. In 1948, Camras² gave a demonstration of three-channel recording for Armour magnetic recorder licensees. And in 1950 the author, then with another company, was asked rather bluntly at a Society of Automotive Engineers round-table discussion, why the recorders that he had sold some of the members did not reproduce properly, with the question, "Why does the recording of an auto going over a cobblestone pavement sound

* Ampex Electric Corporation, Chicago Office, 111 E. Ontario St., Chicago 11, Ill.

¹ *Electrical Engineering*, Jan. 1934, Vol. 53, No. 1, six articles.

² Marvin Camras, in *Proc. I.R.E.*, April 1949, Vol. 37, No. 4.

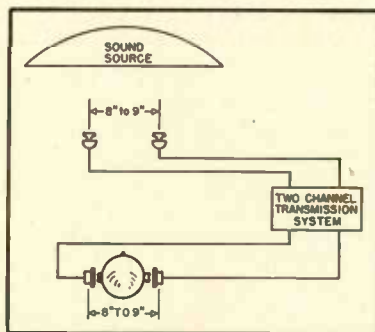

Fig. 1. The elements of a true binaural system.

like a male singer with a cracked voice humming in the bathroom instead of an auto on cobblestones?" Money had been invested in supposedly good equipment, but the reproduced sounds were not considered natural or normal. Some form of distortion seemed to be present.

If one reflects on the difficulties encountered in achieving "realistic" sound effects for ordinary broadcasting (monaural), where crumpled Cellophane sounds like a raging fire in the north woods and a cantaloupe dropped on the floor portrays the victim's head being bashed in, he realizes that all single-channel reproduction gives only an approximation of the original sound—our imagination fills in the deficiencies. For instance, a symphony over the network sounds like a symphony, with which we are reasonably familiar. But recordings of autos on cobblestones do not sound normal, for this sound is a bit unusual and our imagination does not help out much.

Let us consider the "auto-on-cobblestone" problem briefly. Since the one recording microphone, placed in the driver's position, had no analytical or discriminatory power of its own, it recorded faithfully what it heard and, for the first time (perhaps) the auto researchers heard, in truth, what they didn't hear—a hard fact to realize. Obviously, the solution was to restore the natural sense of binaural hearing by using two complete and separate sound transmission channels, from microphones to headphones, one channel to each ear. This was suggested, and one organization tried it with successful results.³ Oddly enough, loudspeaker reproduction, at that time, was not successful for reasons which will become clear as we continue.

³ *J. Acous. Soc. Am.*, Nov. 1952, Vol. 24, No. 6.

Microphone Placement

Apparatus intended for one field often ends up in another. Gene Carrington, educational director and lecturer for a large midwestern organization, learned of the foregoing and made orchestral recordings at Interlochen (Michigan) Summer Music Camp under the direction of Dr. Joseph Maddy. Mr. Carrington conducted experiments with respect to the placement of the two mikes with separations varying from many feet to about the distance of a human's two ears. Headphone listening showed that the sound was most realistic when the mikes were about 8 or 9 inches apart. And the demonstration was astonishing in its realism; one seemed to be standing right in the midst of the orchestra. During the past year, several demonstrations of "binaural" sound have been presented, using two loudspeakers—one for each channel—in a large room. The results were puzzling to many people who attended these demonstrations—until they heard similar demonstrations with headphones. Then they understood what was being attempted. Suddenly "three-dimensional sound," whether reproduced binaurally over headphones or stereophonically over loudspeakers, has become most popular. But this popularity has raised another question. Why don't these demonstrations work so well with loudspeakers? After all, it is mighty inconvenient to listen for any length of time to headphones, and loudspeakers reach larger audiences less expensively.

The answer is that loudspeakers do work very well when properly handled. And here entered the confusion between "binaural" and "stereophonic."

If we refer to Fig. 1, where we have two closely spaced microphones in a sound field, and a two-channel system connecting them to separate earphones, it becomes obvious that we are merely extending the diaphragms of our two ears electrically. Actually, of course, we are extending the diaphragms of the individual headphone receivers, electrically, to the physical placement of the diaphragms of the microphones. The time factor may be suitably delayed by the insertion of a simultaneous, two-track recorder in the bilateral transmission system. In other words, our ears seem to be where the microphones are physically placed. We have re-oriented our ears geographically and individually. The theorem of proportionality exists: mike-to-mike spacing is equal to the earphone-to-earphone spacing, and our brain functions normally to fuse the two

separate signals arriving from each of our two ears. The resultant sensory perception is astonishingly like listening in the spot where the mikes were placed. Of course, we are assuming that we have paid attention to the proper phasing of the mikes, amplifiers, and headphones, and haven't interchanged sides. Disturbing but interesting effects result from such maladjustments. And the quality of the reproduced signal, as always, depends on several factors present in the system: frequency response, distortion, noise, flutter, wow, etc.

But we soon discover that listening to headphones makes the sound appear to be behind, rather than in front of us. This is a fact brought out by Bell Telephone's "Oscar" exhibit at the 1933 Chicago Worlds Fair and now permanently displayed at the Chicago Museum of Science and Industry. And it is also just as tiring today to be squeezed by a headset as when the crystal radio was in vogue. The apparent answer to the problems is obvious. Reproduce the signals over loudspeakers, of course. This will put the sound in front of us, and will be more convenient for listening. But while the sound as we hear it from the two loudspeakers sounds different from single channel listening, it still doesn't sound quite right. Remember, we still have the mikes placed only 8 or 9 inches apart. We have suddenly invented a new system of listening: "bistereonaural" or a cross between two different concepts—which is meaningless. See Fig. 2. The placement of the speakers is unimportant here, as no arrangement will give the desired effect. It doesn't matter whether we set the speakers at an angle so that their axes intersect, as at (A) in Fig. 2, or so that they are square with each other. Speaker manufacturers pride themselves today on the non-directionality and wide-angle dispersion of their products. What happens under these conditions of close mike spacing and wide speaker spacing? If we stand somewhere in front of the

speakers, we no longer receive sound meant for the left ear only in the left ear, and right-ear sound only in the right ear, but rather we receive sound in both ears meant for individual ears only. Our original mike placement simulated our relative ear positions, not the loudspeaker positions. This results in a brand new sensory experience which puzzles that superb analytical instrument called a brain, for the sound is twice mixed: once in the air, because each ear hears sound from each speaker, not just from one as it should; and once in our brain. Since we hear left and right sound in both ears simultaneously, with head diffraction lags, etc., our brains are led to the mental conclusion that we hear two speakers. This leads to the inescapable conclusion that we are befuddled, and this type of reproduction becomes a new and novel experience to be sure. This is certainly not the type of reproduction for which we search, namely that of reproducing the original sound stereophonically (i.e. "in the round"). But with this system there is, however, one point or group of points lying on the perpendicular bisecting vertical plane between the two speakers where, due to phase relationship and standing wave patterns in the reproducing room, we can hear sound from the left speaker predominantly in the left ear and vice versa. Here the results are somewhat more satisfactory. A slight shift of the head will make this interesting phenomenon disappear, and again both sound sources will be heard in both ears simultaneously. This narrow central "binaural" plane limits the number of happy listeners to those who can stand close together in tandem.

Corrective Measures

The answer to this predicament is immediately obvious to anyone familiar with acoustics. In the case of the binaural setup of Fig. 1, we are not concerned with listening room acoustics, obviously, and this occasionally has its

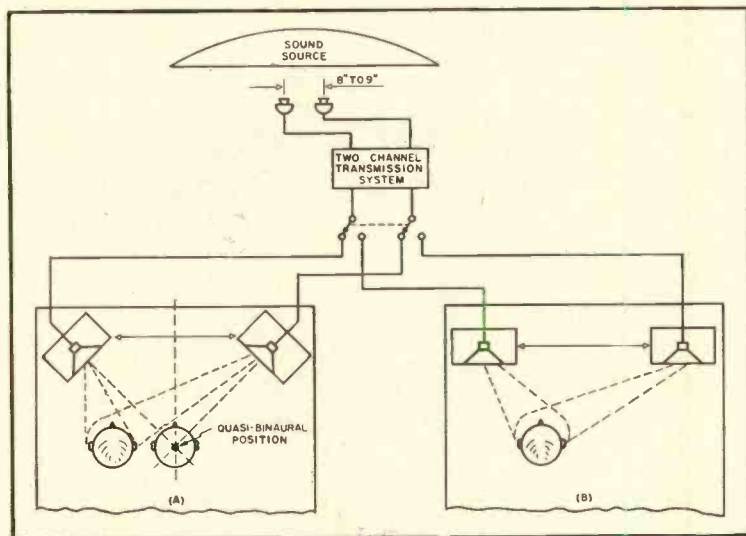

Fig. 2. "Bistereonaural," or mixed and meaningless system.

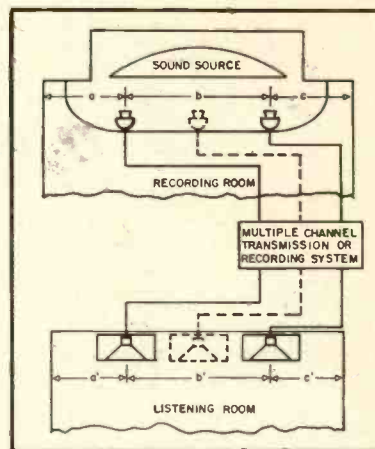

Fig. 3. The true stereophonic system. When three channels are used, distance becomes greater than when only two channels are employed.

advantages. Also, we are not too much concerned with the recording studio acoustics, since our built-in analyzer (brain) compensates for almost all of the acoustic shortcomings of that room, such as excessive reverberation, unwanted echo, etc. This we have learned to do unconsciously since earliest childhood. We use here our binaural sense in the proper and usual manner.

But now, since we wish to reproduce this sound over speakers, we must take the listening-room acoustics into consideration. In fact, the listening room becomes an extension of the recording room. Of course, this has always been true in the case of a one-channel system, but not nearly as obviously so as it now is in the case of the two- or three-channel stereophonic system. After all, we are now trying to re-create that special effect in the listening room which existed in the concert hall.

Let us suppose for a moment that we wished to reproduce a concert, by means of loudspeakers, in the same hall as that in which it had been previously recorded. In reality we should have an infinite number of speakers arranged across the stage and several layers high in order to reproduce a similar full wave front. But for the sake of economy we use only two (or three) and spread them, one to the left, one to the right (and preferably another in the center). If we space two of them at, say, the one-third points across the stage as in Fig. 3 where $a=b=c$, then, by proportionality, the microphones used to pick up the original sound should have occupied the same positions now occupied by the speakers. Sound is then radiated from the points where it was originally picked up. This is a most important factor, a factor relating to the theorem of proportionality. The recording system has merely delayed the element of time. The speakers then deliver approximately the same acoustic pattern into the room that was picked up at those points by the microphones. Sound from all over the stage reaches the various



Fig. 4. A complete portable stereophonic recorder, with amplifiers and power supply.

microphones at varying sound levels and times. These factors are necessary to the proper re-creation of the speaker-reproduced pattern.

If the microphones had been spaced "ear distance" (i.e. about 9 inches apart), as was done in a recent demonstration, and the loudspeakers a similar distance apart to maintain proportionality, rather a neat trick which was not done, we would have had in effect a one-channel system. This would accomplish little toward our ends. But with the speakers spaced widely, we lose the necessary proportionality and achieve only our unrealistic "bistereonaural-phonics" system. Conclusion: the mikes should be spaced as far apart for this type of recording (stereophonic) as the speakers are to be spaced. We must know beforehand what sort of reproducing system is to be used.

Next we add the problem of placing the speakers not in the original room where the sound was recorded, but rather in some other and usually much smaller room, perhaps a living room, whose major dimension is less, perhaps than the distance between the recording microphones. Should we, therefore, reduce the spacing of the mikes? Experiment says no. Experiment also shows that if we space the speakers in approximately the same general lateral arrangement in the smaller room as in Fig. 3, where $a' = b' = c'$, maintaining approximate proportionality, the results are satisfactory. In fact, the sensitive central plane of "binaural" position, referred to previously, disappears and the auditor is free to move anywhere within the listening room. He will experience a similar sensation as though he were to move to various parts of the original auditorium. Placing the speakers in the corners of the room facing diagonally inward or placing them close to side walls appears not to work as well as spacing them a little way in from the walls and square with the room, as in Fig. 3. In so doing apparently a more normal sidewall reflection and multiple image pattern is set up in the room, thus simulating more closely the recording set-up. This helps blend the sound pat-

tern in the room. Corner speakers do not set up such an image pattern.

In general, it is necessary to know where and in what manner the sound is to be reproduced before the proper microphone placement can be stated. For headphone listening, mikes should best be spaced a person's head-width apart. A bag of sawdust between the mikes, simulating one's head, is of unknown

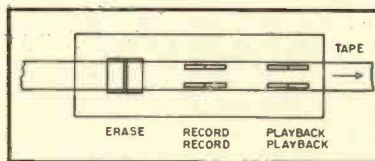

Fig. 6. Diagram of the arrangement of the Ampex stereophonic head assembly.

value. For loudspeaker listening the acoustics of both the recording and listening rooms must be taken into consideration without fail. A wide spacing of the mikes is indicated so that the theorem of proportionality will be maintained. When two channels are used, the mike spacing and position should be chosen with respect to the group size and arrangement so that all sections of the group will appear balanced in the

reproduction. An overly wide spacing of the mikes will leave a "dead" spot in the pickup between the mikes (and speakers) at the center of the group. This is where the third channel, in the center, becomes helpful by really rounding out the stereophonic system. The Bell Labs experiments¹ showed that three channels were an optimum minimum number, but that two would work satisfactorily, if properly handled.

The insertion of a dual AM and FM simultaneous broadcast radio link does not change any of the conditions set forth, obviously, but does limit the system to two channels. Separate-sideband AM transmission plus FM has been suggested for a three-channel system, but appears to be still in the future.

It should be repeated that the quality of the total system will limit the naturalness of the reproduction. This was clearly demonstrated at the November, 1952, concert of the University of Illinois Symphony Orchestra, conducted by Leopold Stokowski, at Urbana, Illinois, where the author was invited to transmit the concert stereophonically to an overflow crowd in a relatively large but acoustically different auditorium on another part of the campus. Stereophonic recordings were made simultaneously. During the rehearsal two cardioid mikes were tried, followed by two modern condenser mikes. The former, designed many years ago, have an increasingly attenuated response above 9,000 cps. The condenser mikes have good high end response. Several of the musical faculty present commented on the noticeable difference, and the more nearly true string and oboe tone resulting from the switch. No other elements of the system were changed.

One controversial point might be raised here. What mike pickup pattern should be used? The author prefers a cardioid pattern, but with a wide frequency response. This pattern seems to help stereophonic reproduction because the pickup thus is one-sided, while the speaker reproduction is other-sided. This would seem to help in making the listening room an extension in fact of the recording studio.

[Continued on page 57]

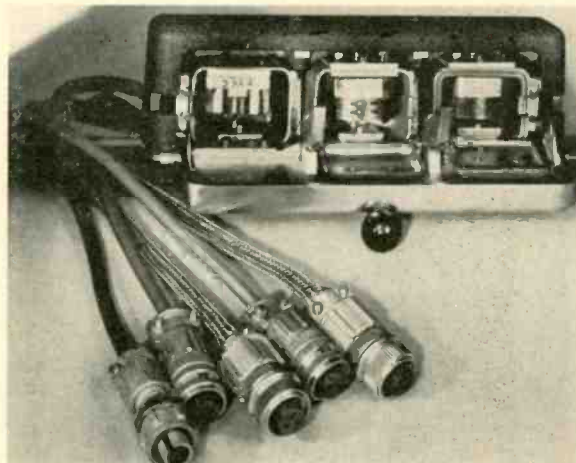

Fig. 5. Stereophonic head assembly, employing a full-track erase head at the left, a two-track record head, and a two-track playback head at the right.

Two-Channel Conversion for AM-FM Receivers

C. G. McPROUD

Details of simple changes which give the advantage of two separate receivers to tuner chassis which employ independent AM and FM channels but with coupled tuning capacitors. Ideal for binaural or stereophonic broadcast programs.

SOME TIME AGO, the writer made a few changes to a standard AM-FM tuner chassis in order to be able to listen to one program on FM while recording another on AM, or vice versa, all without realizing how advantageous this modification would be when radio stations started to use their two transmitters to radiate the two-channel signals for binaural or stereophonic programs.¹

The whole idea is so simple and straightforward that anyone faced with the problem of providing both AM and FM programs simultaneously from a single tuner should come up with the same solution. However, since such a solution has not yet appeared in print, this one is offered as one way to accomplish the desired end.

At the time the modification was planned, there were no stations regularly broadcasting two-channel programs, but it must be admitted that there are times when two programs of interest are on the air at the same time, and the human hearing and interpreting mechanism is unable to cope with both at once. For this problem, the simplest solution is to record one of the programs. As one element of the writer's home system, a wire recorder was employed for just this purpose. The quality left something to be desired, but it was at least good enough to convey the information contained in the program—probably as well as any of several million table-model sets that serve as the sole entertainment medium in many households. At one time, this system employed two separate tuners—originally a wide-range t.r.f. tuner of the Miller type, with modifications of course, and the other an inexpensive FM tuner with a ratio detector.

The next step in the program of improvement included the design and construction of separate AM and FM tuner chassis, both tuned by means of push buttons. The FM tuner used relays to switch adjustable capacitors in the oscillator circuit, while the other used relays to switch the plate supply to any one of four single-channel fixed-tune chassis.

¹ With no intention of getting into this controversy as to the correct name—at least not in a constructional article—the writer respectfully refers the reader to discussions on this subject by Tinkham on page 22 and Canby on page 46.

This entire system was described in an earlier series of articles.²

The next step in the program was to secure a combination AM-FM tuner of good quality, with the idea of separating the sections so as to have the advantages of two-channel reception if desired. Because of its physical construction, the Browning RJ-12B was selected. In this receiver—as in several other types—the tuning is accomplished by two entirely independent variable capacitors, coupled together only by means of a dial cable. The modifications are now reasonably obvious. With the advent of two-channel broadcasting for binaural or stereophonic programs, the receiver becomes doubly useful.

Before discussing the actual modifications to the RJ-12B, let it be said that the general idea of these changes can be adapted to any AM-FM tuner which uses separate devices to tune the two sections. The Browning RJ-20 is similar to the RJ-12, and the Meissner 9-1091 may be converted in a similar manner. The details may differ, but the principle remains the same. For simplicity, only the changes to the RJ-12 will be described, and they are divided into two parts—electrical and mechanical.

Electrical Changes

The electrical changes required are simple, and are made primarily to permit the simultaneous operation of both

channels. In the system for which this modification was made, the switching between AM, FM, and Phono is accomplished in the control amplifier. Therefore, since the phono and the TV inputs to the tuner were never used, it was preferred to eliminate this switching facility from the tuner chassis. However, to reduce current drain and consequent heating, a selector switch was used to permit operation of either channel separately or both together. This switch has three positions—the center providing for both AM and FM operation, the left position energizing only the AM tuner, and the right position energizing only the FM tuner.

In addition, neither the volume control nor the power switch were needed on the tuner chassis, both being provided elsewhere in the system. Therefore both of these were removed. As a matter of fact, when the RJ-12 is to be used in a typical modern system which incorporates a control amplifier, both of these components may be removed, leaving only the two central knobs on the tuner chassis—one for tuning and the other as the selector. However, for the modification, two tuning shafts were needed in addition to the selector switch, so in order to preserve symmetry, the a.f.c. switch was wired to the front panel, which is somewhat more convenient than its normal back-apron location. Thus we have four control positions on the front of the chassis—a.f.c. switch, tuning, selector, and blank. The original controls were, in the same order, the power switch, tuning control, selector, and volume. *Figure 1* shows the

² C. G. McProud, "Elements of residence radio systems." *AUDIO ENGINEERING*, Sept.-Dec. 1948. Reprinted in *AUDIO ANTHOLOGY*.

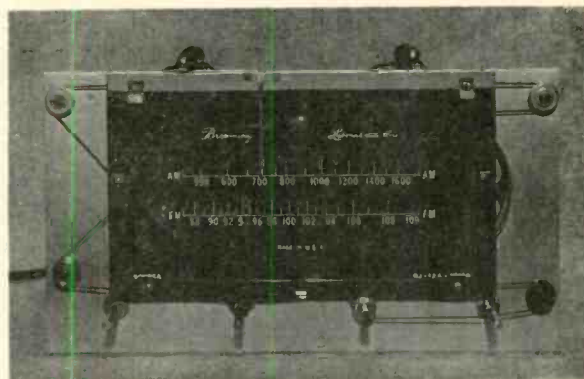

Fig. 1. External appearance of the converter Browning RJ-12B tuner, showing the two dial pointers.

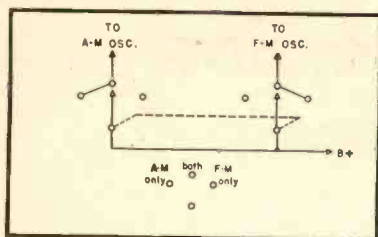

Fig. 2. Schematic of the switch connections to be made in making the conversion.

front of the modified chassis, which is but slightly different from a normal chassis. It will be noted that there are two dial pointers—the one at the top extends only to the AM dial scale, while the new one at the bottom extends upwards to the FM dial scale.

Taking the changes one by one, the following procedure should be followed. Remove the power switch and its associated wiring. Remove the volume control, leaving the wires disconnected but at the same location temporarily. One of the r.f. coils will have to be pushed slightly backward to permit the control to be removed. If done carefully, no damage should result. Now, remove the selector switch, leaving all its wiring intact. This will save a lot of tracing when connecting the new switch. All the shielded wires from the switch to the jacks on the rear apron may be removed, making it easier to get the switch out of the way. Next, remove the tip jacks marked AUDIO OUTPUT and RECORDER INPUT—the first and third from the left end of the rear apron when viewed from the back of the chassis. In the two holes, mount two 1.0-meg audio-taper potentiometers, wiring the arms to the adjacent tip jacks, and the ground end to a chassis ground lead. Connect a .05- μ f capacitor from the junction of R_{11} and R_{12} (in the Browning diagram)—from which a shielded lead to the switch was removed—to the high end of the potentiometer nearest the AM end of the chassis. Connect another .05- μ f capacitor from the junction of R_{17} and C_{11} to the high end of the other potentiometer. These two potentiometers permit adjustment of the outputs to equal levels.

Install a two-pole three-position switch (Centralab 1462) in the hole from which the selector switch was removed, and connect the new switch as shown in Fig. 2. The remainder of the leads should be connected so that the indicator tube works on both sections of the receiver at the same time. To accomplish this, connect the lead from pin 5 of the 6AL7 socket to the AM a-v-c bus; connect pin 4 to the ground end of the discriminator network; and connect pin 6 to the "high" side of the discriminator output, through a 1-meg. resistor. Thus the plate supply is connected to the AM oscillator in the left and center positions of the switch, and to the FM oscillator in the center and right positions.

New A.F.C. Switch

The normal a.f.c. switch in this chassis is a single-pole double-throw slide switch mounted on the rear apron. By prying up the tabs on the sides of this switch, the slider element may be removed and upon replacing the rear bakelite plate of the switch, the wiring is not disturbed and the terminals serve merely as tie points. Install a single-pole double-throw rotary switch on the front apron where the power switch was, and connect three wires from the old switch to the new one, making sure to maintain the same operating arrangement.

After cutting the shafts to the same length as the original tuning shaft, the electrical changes are completed. One hole remains unoccupied on the front apron—that from which the volume control was removed.

Mechanical Changes

The first step is to remove the dial and all the dial stringing. Then remove the large pulley from the AM tuning capacitor shaft, and remove the smaller pulleys from both capacitor shafts. Mount a $\frac{1}{4}$ -to- $\frac{3}{8}$ shaft extension on the FM capacitor shaft, and firmly attach a new 4-in. pulley to this extension, making sure that the dial cable opening in the pulley is at the bottom when the capacitor is half meshed. Remount the 4-in. pulley on the AM capacitor shaft, with the groove of the FM pulley about $\frac{1}{16}$ -in. further from the panel than the AM pulley. Mount a tuning shaft of

the same type as the present one in the hole from which the volume control was removed, and mount two $\frac{3}{4}$ -in. idler pulleys as shown in Fig. 3. These pulleys must be free to turn easily, and eyelets for mounting them are usually supplied with the pulleys. Note that the bottom of the left idler is on a line with the top of the right one, and that this line is slightly above the bottom edge of the glass dial plate. A third idler pulley should be reamed out to run freely on the $\frac{1}{4}$ -in. selector switch shaft.

Following the diagram of Fig. 4, carefully restring the AM dial cord. This cord is shown in solid lines and should be drawn up so as to be quite tight, with the spring extended to about $1\frac{1}{2}$ times its normal length. Where the dial cord wraps around the knob shaft, it is suggested that three turns be taken. Test the stringing before proceeding, making sure that the knob shaft turns freely and that the dial cord behaves properly in the shaft depression.

Following a similar procedure, string the FM cord, using the dotted lines of Fig. 4 as a guide, and again test the operation thoroughly before proceeding further.

It is suggested that two similar dial pointers be obtained—the writer prefers the type which are made of a fluorescent plastic as they are easily seen. Since one is to slide along the top of the dial plate and the other along the bottom, try them out first, and cut off short enough that they clear, yet long enough to reach the dial calibrations. Then remount the dial plate and attach the top pointer, using a few drops of radio cement in addition to crimping the back of the slider. The vertical line at the left end of the dial scale indicates the position of full meshing of the capacitor plates for both sections. Therefore, the pointer should be secured to the dial cord at this end of the dial and with the capacitors fully meshed.

The FM pointer is similarly mounted to slide along the bottom of the dial plate. This may take some careful adjustment to make sure that the pointer passes the other cords without catching, but it can be done with a little care. It is suggested that the sliders be given a light coating of Lubricate or some similar lubricant.

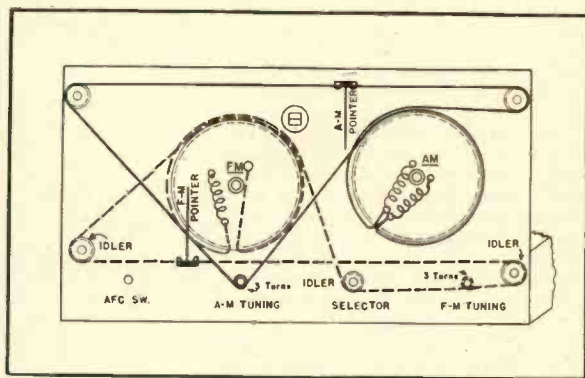
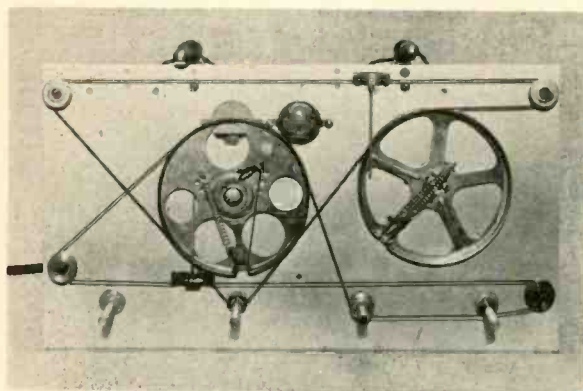

Fig. 3 (left). The tuner chassis with the dial plate removed to show the dial stringing. Fig. 4 (right). Diagram of the dial stringing. The solid line indicates the path of the AM cord and the dotted line shows the path of the FM cord.

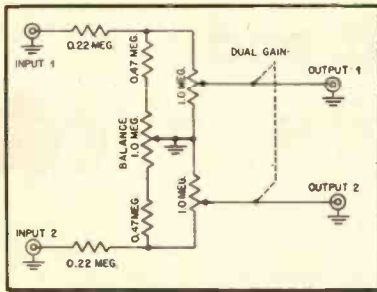

Fig. 5. Schematic of simple control for stereophonic programs.

Output Circuits

For use as a tuner capable of receiving two separate monaural channels, nothing further is required, since the two output jacks on the rear apron provide the AM and FM signals independent of each other. However, for binaural use, some means of controlling the volume of both channels simultaneously is an advantage. Therefore it is recommended that a separate control unit be provided. This unit can be as simple as possible, containing only a dual potentiometer, relying upon the two output controls on the tuner chassis for balancing levels between the two sections of the receiver. If a more elaborate unit is desired, so that either channel can be connected to either power amplifier or to both at will, it is equally possible to make such an arrangement. In any case, if the unit is to be used primarily for stereo programs, the balancing control is desirable. Figure 5 shows a simple control, without any provision for switching, yet equipped with the balancing feature. This entire unit can be mounted on a small bracket or on an unused space on the front panel of the installation. To reduce the number of apparent controls, it is suggested that the complete unit be assembled using an IRC Concentrikit, with the balancing control operated by the outside knob, and the dual potentiometers operated by the small inside knob. The parts list shows the components for either type of construction.

A more flexible control system is shown in Fig. 6. The selector switch has five positions—(1) both AM and FM channels feeding separate output circuits, with AM on output 1 and FM on output 2; (2) same as (1) except that AM is on output 2 and FM on output 1; (3) AM feeding both output circuits; (4) FM feeding both output circuits; and (5) stereophonic, with the dual volume control and the balancing control in the circuit. The only eventuality not provided for is the reversal of the stereophonic sources, which could become necessary in certain instances. This was not included because of the impracticality of locating a four-pole six-position switch of reasonable dimensions. However, it is probable that some standardization in channel usage will occur, so that the FM channel is always on the left and AM on the right, or vice versa. Since the normal orchestra arrangement places the high-frequency instruments

predominantly on the left, it is probable that FM would be the left channel.

The balancing control provides a loss of about 3 db in each channel in the center position, with a variation of 3 db in the level of either channel as the control is rotated from one end to the other. If the control unit is to be used with amplifiers at any appreciable distance, it would be desirable to add two cathode followers, as shown in Fig. 7. There is some additional gain in this circuit so the balancing control has a mid-position loss of 6 db in each channel, with a range of 6 db from one end of the control to the other. The output from this arrangement is approximately the same for all positions of the switch, and one additional position has been added to permit reversal of the sides in the stereo posi-

tion. The output impedance is sufficiently low that amplifiers may be located up to 20 feet from the control unit without appreciable frequency discrimination.

PARTS LIST

Receiver Modifications

- 1 2-pole, 3-position switch, Centralab 1462
- 1 SPDT rotary switch
- 2 1.0-meg audio-taper potentiometers, small size
- 2 .05- μ f capacitors, 400 v., paper
- 1 Dial drive shaft with panel bearing
- 3 $\frac{3}{4}$ -in. idler pulleys
- 1 4-in. dial pulley, with tension spring
- 1 Shaft extension, $\frac{1}{4}$ -in. hole, $\frac{3}{8}$ -in. shaft
- 2 Slide-rule dial pointers
- Nylon dial cord

For Figure 5

- 1 1.0-1.0 meg. dual potentiometer, audio taper
- 1 2.5-meg. potentiometer, linear or, if concentric control is used
- 1 IRC K-2 Concentrikit
- 1 IRC KS-2 Universal Shaft Kit
- 1 IRC B11-239 base element
- 1 IRC B13-137 base element
- 1 IRC M13-137 base element
- 4 Input jacks, RCA Phono type
- 2 0.22-meg. resistors, $\frac{1}{2}$ -watt
- 2 0.47-meg. resistors, $\frac{1}{2}$ -watt

For Figure 6

- Same parts as for Fig. 5, with the addition of
- 1 Centralab 1414 switch

For Figure 7

- Same parts as for Fig. 6, except for the substitution of the following for the resistors listed:

- 2 0.27-meg resistors, $\frac{1}{2}$ -watt
- 2 0.39-meg resistors, $\frac{1}{2}$ -watt
- 4 0.47-meg resistors, $\frac{1}{2}$ -watt
- 2 0.1-meg resistors, 1-watt
- 2 10,000-ohm resistors, 2-watt
- 2 3900-ohm resistors, 1-watt
- 2 Noval sockets
- 2 12AU7 tubes
- 2 0.1- μ f capacitors, 600 v., paper.

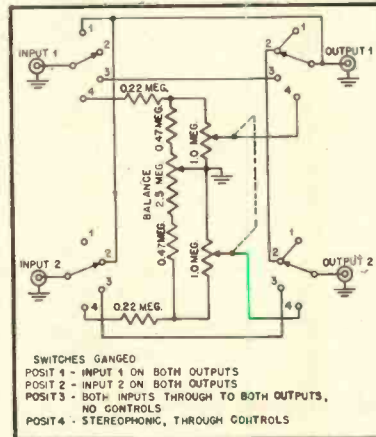

Fig. 6. The addition of a switch provides greater flexibility in the operation of the converted tuner. With the switch at A, input 1 is connected to both outputs; at B, input 2 is connected to both outputs; at C, each input is connected to a separate output, without the volume and balancing controls in the circuit; at D, the inputs are connected through the controls for binaural programs.

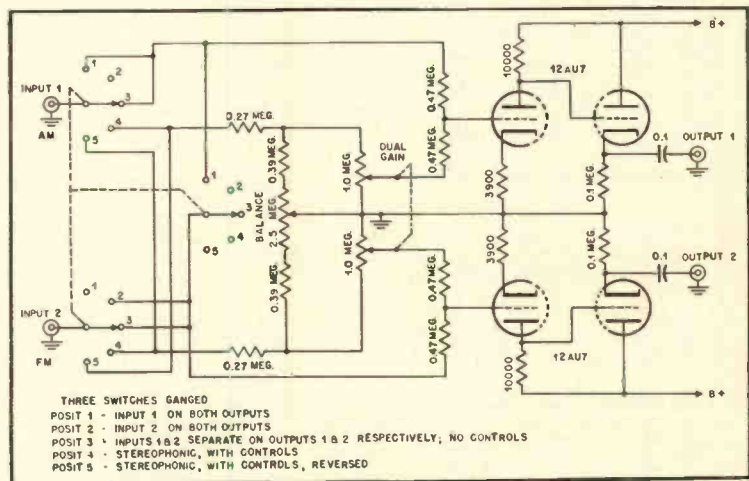

Fig. 7. Similar switching plus the addition of two cathode followers may be preferred because of the lower output impedance offered with this arrangement.

A Flexible Single Recording and Re-Recording Channel

HAL MAGARGLE*

A typical motion picture studio sound system condensed to meet the requirements of a small plant with a need for great flexibility with a minimum of equipment.

THE AUTHOR HAS FOUND in his too short an existence in the business of recording sound motion pictures, especially in the transmission end, that there are books available if you want to delve into the basic theory of recording, and that there are also quite a few allied books available on a high engineering level. However, when the time came to design a recording channel, the needed books were not available to the writer, and he had to take his knowledge piecemeal or by word of mouth as best

he could. This paper describes the channel which finally evolved—one which, in the writer's opinion, can be classed as an optimum single recording channel which will perform every duty necessary for the producer with a limited amount of space and equipment inventory. As mentioned, it is a single channel but, of course, can be used to record on different media simultaneously.

The entire channel centers around the RCA MI-10238 Main Recording Amplifier which was modified by RCA to include a jack bay in the lower part of its sub base. This jack bay consists

of a single strip of jacks upon which are terminated the compressor, high- and low-pass filters, film equalizer, and trunk lines, as well as miscellaneous other jacks as noted on the schematic. These jacks were installed mainly to facilitate test duties on the unit; however, they make an excellent position from which to evolve the rest of the channel.

Basic Equipment Layout

Following the schematic—Fig. 1—from the sound sources to the recorders, we note the microphones and film and

* 5130 H St., S.E., Washington 19, D. C.

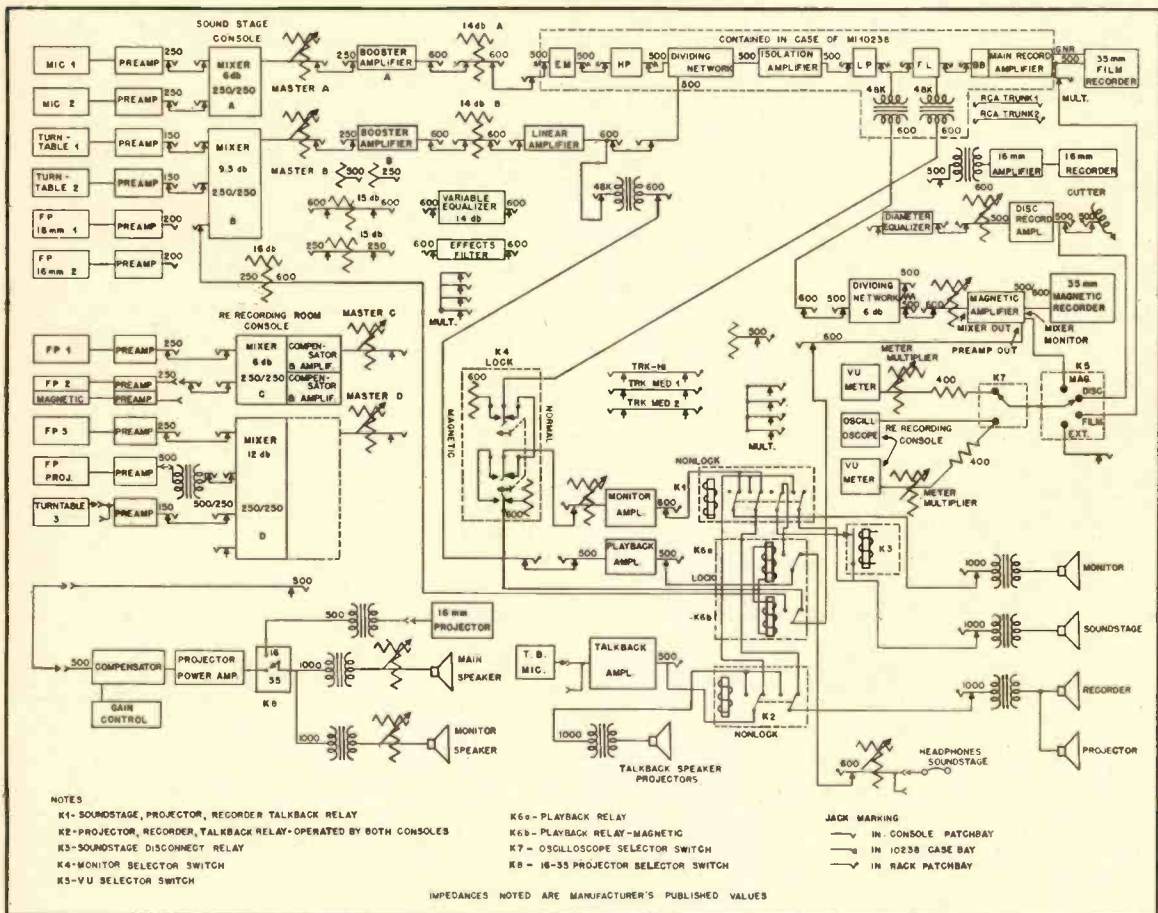

Fig. 1. Overall block schematic of the flexible single-channel sound recording and re-recording system.

disc phonograph machines. These units are conventional, and in all cases the preamplifiers shown are located as close as possible to the microphones or machines, with the signals then being piped into their respective mixing pads. To eliminate a large console, with a pad for every unit, each preamplifier is terminated on jacks and then the most popular set-up is normalled along the line. Because the channel must be versatile and one man—the mixer—must be in complete control of the signals, the entire patching needs are taken care of in one localized spot, again with a minimum of units to operate. In fact, the majority of the jobs done with the channel need no patching whatsoever, and in the remaining cases only a few patches are needed. This is with exception of the re-recording room which has to be patched into the circuit whenever needed. Even here, only two patch cords are needed to change the channel completely from the scoring stage to the re-recording room, everything else being normal. The patches involved are for the mixer positions only.

After mixing in the respective mixing positions, the signal is amplified conventionally and fed to the main recording amplifier. At this point is encountered another modification to the MI-10238 amplifier. The original amplifier could receive one signal only, and either compress it or pass it through in a linear fashion. With the modification, one signal can be compressed, if desired, while the others are sent through linear. The linear amplifier could be replaced with an external electronic mixer (compressor) but in this case it was not needed. All original recording is compressed, with the exception of the location sound which is recorded on the RCA PM 62-A 35-mm magnetic film recorder. This unit has no compressor, and one has never been found neces-

sary because of the latitude and range of the magnetic medium. When the original sound is later transferred to the optical film for the subsequent cutting and dubbing operations, it is then compressed. This is a very satisfactory arrangement because the background noise of magnetic recording is so low that the over-all level in the transfer can be raised by compression almost as much as wanted. Without exception, the original signals on disc or optical film are compressed before actually being recorded. Any of the other recording systems—35-mm magnetic (which is normalled through), disc equipment, or 16-mm recorders—can be patched into the compressor unit of the main recording amplifier. The amount of compression to use is selected by the nature of the sound being recorded, with the compressor set up for limiting duty only during re-recordings. This holds true in almost every case—the exception being “news reel” type re-recordings where the narration is compressed while music and sound effects are left normal. This type of operation is quite simple for this channel and can be set up in the same amount of time as that necessary to set up for voice recording only. When a special type of job is encountered, multiple jacks, attenuator pads, and loading resistors are available for use in these set-ups, if needed, as are two external filter equalizer units—one a variable equalizer to boost or attenuate the highs or lows as needed, and the other a variable sound-effects filter for telephone filtering and similar uses. These two units together are effective in forming a frequency response to match practically any curve needed, including dialog equalization and 16-mm or TV film characteristics. They may also be used to advantage in disc recording work. All the disc equipment is sync, and is direct drive, so that it

may be used for any lip-sync or direct sound as needed. The equalizers used for re-recording are the standard-type compensators, and they are used *only* for re-recording. As such, they are an integral part of the re-recording console.

After the signal is combined at the output of the electronic compressor and linear amplifier it passes through the high-pass and low-pass filters and the film equalizers, and thence to the 35-mm recorder. The monitor amplifier is bridged in the circuit ahead of the film-and-slit-loss equalizer so that it needs no compensation and can be used for other duties besides monitoring. During re-recording, the amplifiers in the re-recording theatre are compensated to adjust for room acoustics in order to get the proper balance in tonal quality. These same amplifiers and compensator are used when composite prints are projected for screening. The projector for the re-recording room is a standard Brenkert projector equipped with a preview attachment and a multiduty motor, and it does double duty for interlock shows to clients and as a fourth film phonograph when needed—using the sound head without having to thread through the picture aperture. This sound head is the only one not equipped for push-pull operation, the other three having that feature.

The output of the low-pass filter is bridged and the signal divided to permit recording on other systems simultaneously or for re-recording monitoring. The magnetic recorder is normalled from this bridging coil to receive whatever signal the optical recorder receives. Some engineers may feel that the magnetic should be fed by a signal free from high- and low-pass filters, to take advantage of its inherently fine frequency response, but here it is felt that

[Continued on page 64]

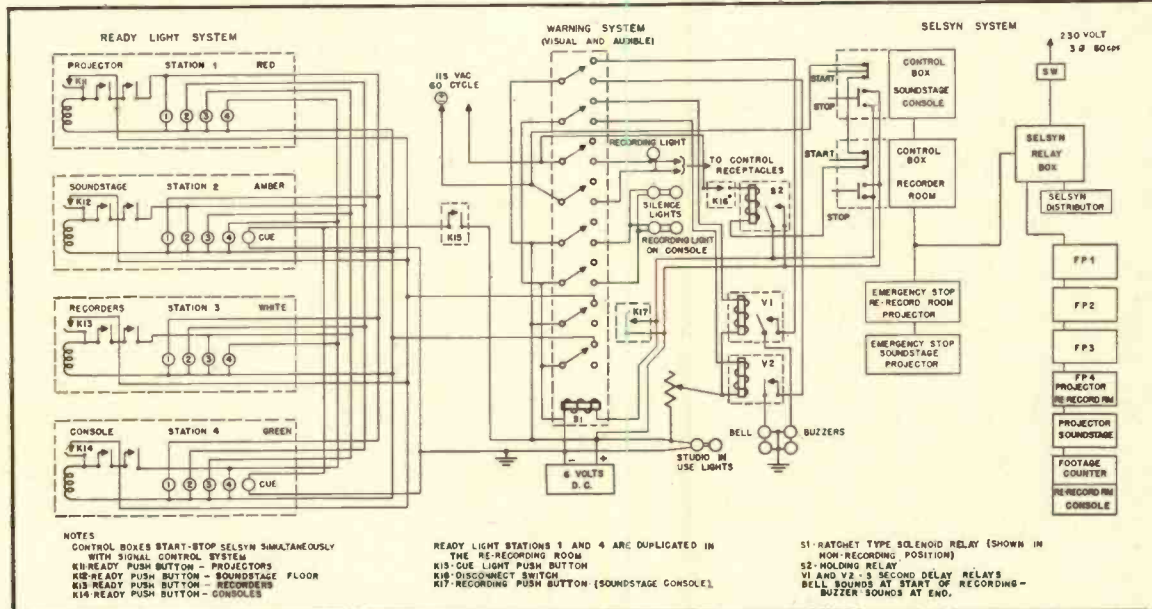

Fig. 2. Signal light and motor control system for small motion picture sound plant.

Handbook of Sound Reproduction

EDGAR M. VILLCHUR*

Chapter 8. Elements of Fidelity in Sound Reproduction

A discussion of the characteristics of a reproducing system which must be considered in evaluating the performance in terms of its fidelity.

THE CHARACTERISTICS of a (monaural) reproducing system that determine its ability to reproduce sound faithfully may be categorized as:

- Frequency response
- Transient response
- Harmonic distortion
- Intermodulation distortion
- Power capability
- Noise level
- Dynamic range

Frequency Response

Frequency response is the most widely discussed factor in sound reproduction, and is often the first technical expression that the audio novice learns, although he is frequently led to accept a very incomplete meaning for the term. The frequency response of a system refers to the relative amplitude with which sounds or components of sound, varying only in that they are of different frequency, are reproduced. This response is typically such that a certain band of the frequency spectrum is reproduced with a given degree of uniformity, with output beyond the ends of the band dropping off. When the drop is sharp it is called *cut-off*; when it is gradual it is referred to as *roll-off*.

Thus there are two aspects of frequency response: the range of frequencies covered by the reproduced band with a specified minimum response, and the type and degree of variation which occurs within the band. Except

* Contributing Editor, AUDIO ENGINEERING.

Fig. 8—1. Frequency and intensity ranges of speech and music. The solid line represents the limits of normal hearing. (Courtesy Bell Laboratories Record, June, 1934)

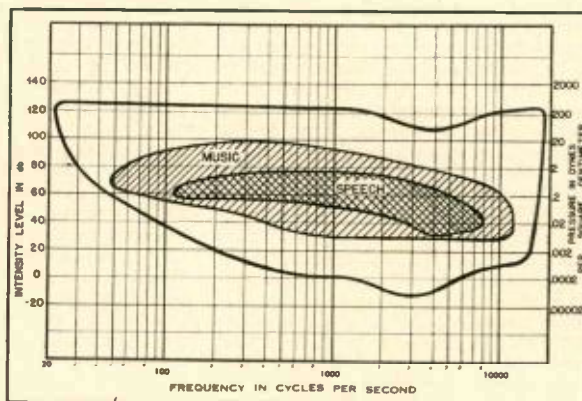

where the range is very inadequate, the second of these aspects is usually the more important. So-called frequency response ratings which merely record the two frequency extremes of the reproduced spectrum may have little relationship to the quality of sound to be expected. Two loudspeakers with the same response at 40 and 15,000 cycles may produce entirely different tonal qualities due to the dips and peaks of acoustical output at less extreme frequencies.

Uniform or "flat" response over the band of reproduced frequencies is desirable when two conditions are satisfied. These are: (1) that the reproduced sound is at the same intensity level (produces the same number of acoustical watts per square centimeter) as the original sound at a normal listener's po-

sition, and (2) that acoustical conditions in the room in which the sound is reproduced create more or less the same frequency discrimination as conditions in the original hall. When these two conditions do not exist, as is often the case, a rising bass characteristic to compensate for the Fletcher-Munson effect (see Chapter 6), and some tonal adjustment for discriminatory acoustical conditions should be provided by variable tone controls.¹

We have seen that intensity differences on the order of a fraction of a db are just discernible at most frequencies and intensity levels, but this perceptive sensitivity is for single, pure tones heard under laboratory conditions. The degree of non-uniformity of frequency response that can be tolerated without effect on the quality of reproduction is undoubtedly somewhat greater, probably on the order of plus or minus one to two db. The indicated standard for maximum variation in frequency response is easily met in electronic circuits, more difficult to achieve in pickups, and, up to the present, an impossible ideal for loudspeaker systems, the very best of which reproduce their spectra with a variation of plus or minus five db. When sections of the frequency band are reproduced with ten db greater amplitude than others, tonal coloration must be expected.

¹ The tone controls of an amplifier also provide compensation for associated equipment and program characteristics, but this discussion is limited to the desirable frequency response of the complete system.

Fig. 8—2. FCC limits of frequency-response variation permitted FM broadcast stations (corrected for pre-emphasis). The range from 100 to 7,500 cps is restricted to a variation of ± 1.5 db, while the standards beyond this band are not as strict. (The minimum frequency response standard for AM stations is 100-5,000 cps, ± 2 db.)

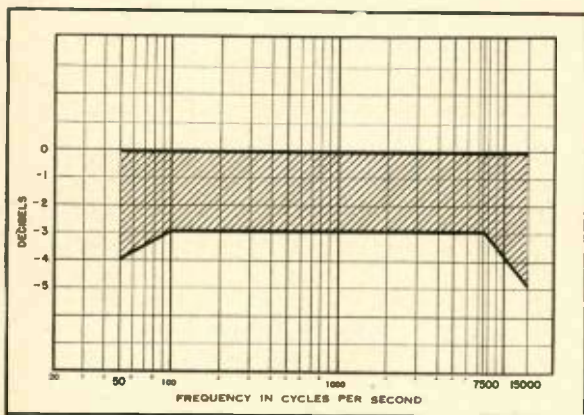

The range of frequency response required to reproduce orchestral music without such coloration, and to include all significant overtones, transient effects, and noise, is not a matter for theorizing but for experimental verification. We are not concerned with reproducing all of the acoustical energy of the orchestra for its own sake, but only that part of it which has significance in the perception of quality.

Figure 8-1 is a chart reproduced from the *Bell Laboratories Record*, which includes information on the frequency ranges required for the reproduction of music and speech. This chart agrees closely with the data appearing in Snow's graph of audible frequency ranges for speech and music (see Chapter 5). We may consider the frequency range for perfect apparent fidelity of speech reproduction to be from 100 to 8,000 cps (Snow uses a slightly higher upper limit for female speech), and the range for perfect apparent reproduction of orchestral music as 40 to 15,000 cps.² A study in detectable band-width differences³ has indicated that this last upper

organs in the world which produce subsonic 8-cps fundamentals should not unduly influence the design of a reproducing assembly made for home entertainment.

Sometimes too great a concern with extending the frequency limits of reproduction to extreme values has led to rationalizations of the need for such extension. It has been stated, for example, that sound reproducing equipment must be capable of transmitting supersonic and subsonic sums and differences between the frequency components of music, or that a band-pass extending into the subsonic region is necessary to reproduce properly a sound whose intensity is changing at a subsonic rate. We have seen that sum and difference frequencies of an intermodulatory nature can only exist when the signal is passed through a non-linear device such as the ear; whatever such intermodulation products will be formed in the ear of the concert listener will also be formed in the ear of the listener at home, without direct transmission of these products. As for variations of

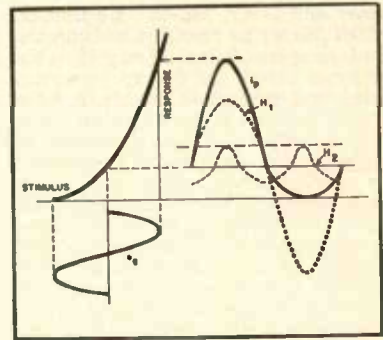

Fig. 8-3. Generation of second harmonic distortion by a non-linear transfer characteristic. The actual output, i_0 , may be analyzed into fundamental and second harmonic components, shown as H_1 and H_2 . e_0 is the input signal. (After Reich, *Theory and Applications of Electron Tubes*; courtesy McGraw Hill Book Co., Inc.)

variation allowed FM broadcast stations by the FCC.

Balance

Tonal balance refers to the symmetry of frequency response deficiencies relative to the mid-point of the audio-frequency spectrum. Since there are an equal number of useful octaves on each side of the geometric mean, which is about 800 cps, this frequency constitutes the perception mid-point of the spectrum.

It is generally considered desirable to balance losses in the treble region with more or less corresponding losses in the bass, and vice versa, even though some sacrifice from absolute fidelity is involved. This view may be explained by an analogy in the field of color reproduction of pictorial material. Inadequate reproduction of the cold blues and greens, giving a picture a warm reddish cast, could be offset by a corresponding reduction in the intensity of the warm oranges and reds, a reduction which, while it involved a loss of absolute fidelity, might serve to give the picture a less artificial character.

Aural balance is often discussed in terms of the relationship between the

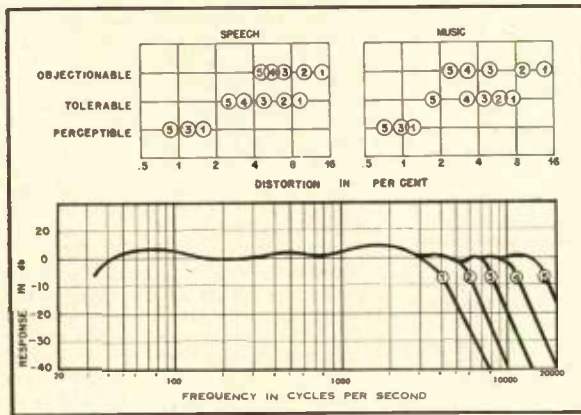

Fig. 8-4. Objectionable, tolerable (for low-fidelity units), and perceptible total rms harmonic distortion in music (produced by triode), for various frequency cut-offs. (From Olson, *Elements of Acoustical Engineering*; courtesy D. Van Nostrand Company, Inc.)

limit must be reduced to about 11,000 cps before the change becomes noticeable. It may be inferred that a corresponding liminal (just noticeable) change in the bass limit would probably be to 60 cps or higher. These latter figures may therefore be taken as reasonable standards for a high-fidelity reproducing assembly one step down from perfection as far as frequency range is concerned.

The only standard orchestral instruments whose fundamental frequency ranges go below 40 cps are the piano, the harp, the pipe organ, and the contra bassoon. It has been experimentally established that the fundamental energy in the very low notes of the piano is so small as to have no effect on perceived quality, and it is logical to assume that the same is true of the harp. The extreme low-frequency contributions of the two other instruments will rarely be a factor in the tonal value of reproduced music. The fact that there are a few

sound intensity at subsonic frequencies produced by vibrato, beats, or other causes, such effects are not tones in themselves but amplitude modulations of the wave envelope. Just as the coupling circuits of broadcast AM receivers transmit the wave envelope of the r.f. carrier without having any direct response to the audio frequencies involved, the audio reproducing system does not require subsonic response in order to transmit and reproduce amplitude variations of subsonic frequency. A mathematical analysis of the varying signal finds the modulating frequency conspicuously absent.

The frequency-response range of stages of the reproducing system within a feedback loop must be extended far beyond the audible limits in order to prevent phase shift and regeneration. Phase shift in the overall system, however, has little effect on perceived quality (see Chapter 6), and is, in any case, normally introduced by the reactive elements of tone controls or equalization networks.

Figure 8-2 shows the minimum frequency-response range and maximum

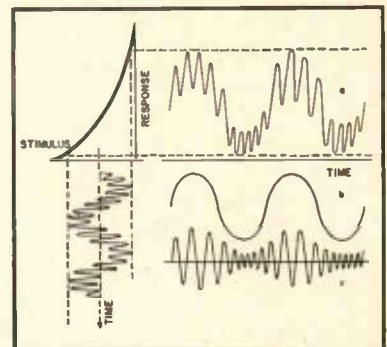

Fig. 8-5. Intermodulation produced by non-linear transfer characteristic and attendant distortion. (a) is the output signal, (b) and (c) are the distorted low-frequency component and the amplitude modulated high-frequency component, respectively. (From Reich, *Theory and Applications of Electron Tubes*; courtesy McGraw Hill Book Co., Inc.)

² These are the figures used in *Musical Engineering*, by H. F. Olson.

³ D. K. Gannett and I. Kerney, "The discernibility of changes in program band width," *Bell System Technical Journal*, Jan. 1944.

upper and lower "cut-off" frequencies, which this writer considers unfortunate. Such an approach is valid only when the response curves are flat up to certain points and then cut off sharply. A more typical condition involves gradual losses over a fairly large band at the end of the spectrum, which would be balanced by similar losses symmetrical (on a logarithmic scale) to the mid-point. An additional difficulty in achieving balance by selection of cut-off frequency is that a change of frequency range involving only the bass extreme of the spectrum will leave the general character of the sound unchanged during the major part of most music, when there is no significant energy present in this frequency region. One conclusion about which there seems to be agreement, however, is that there is a large amount of latitude permissible before the response becomes audibly unbalanced. Most tone control circuits are capable of making the necessary corrections.

All of the above discussion of frequency response refers to the effect on a listener at one particular position. It is important, of course, that the response be as uniform as possible over as wide an angle as is required to cover all listening positions.

Transient Response

Proper reproduction of the instantaneous wave forms associated with the starting and stopping of sound vibrations requires a much more extended high-frequency response than is called for by the steady-state tone. The initial percussive or plucked impulse contains many high-frequency partials which are not part of this steady tone and which disappear after a short time.

Inadequate high-frequency response deadens the quality created by transient components. But transients suffer from accentuated response as well. The existence of a resonant response peak increases the tendency of the system, when stimulated by an impulse (especially at or near the frequency of the peak), to continue to oscillate after the stimulating impulse has stopped. This tendency is directly proportional to the height of the peak and to the extent to which it is confined to a narrow band of frequencies, that is, to the "Q", and is inversely proportional to the degree of damping. The effect is called *hangover*

in the bass; in the treble ranges it is often referred to as *singing*. We thus see that transient response is directly related to both the range and the uniformity of frequency response.

Distortion

The output of a device is said to be distorted when the instantaneous response is not directly proportional to the instantaneous stimulus at all times. This distortion has several synonymous titles: it is called *non-linear*, *amplitude*, or *harmonic*. Figure 8-3 illustrates how the wave form distortion produced by a non-linear transfer characteristic⁴ may be analyzed into partials consisting of the fundamental and second harmonic.

The spurious harmonics that are created in this way do not have as great a direct irritation value as might be supposed. They are, after all, harmonically related (in a musical sense) to the fundamental, and they may serve to intensify or cancel natural harmonics which already exist. Yet harmonic distortion is very unpleasant, and we are sensitive to very small amounts of it, as indicated in Fig. 8-4.

The explanation lies largely in an effect of harmonic distortion called intermodulation, which was touched upon in the discussion of subjective tones. When a complex tone consisting of both low- and high-frequency components is passed through a device with the transfer characteristic of Fig. 8-3, the high-frequency signal will be reproduced with increased amplitude during most of the first half of the cycle, and with reduced amplitude during most of the second half of the cycle. This is because during these periods the device has, in turn, exaggerated and diminished response to all stimuli. The amplitude modulation created by this non-linear transfer characteristic is illustrated in Fig. 8-5.

Certain wave forms, such as those produced by combinations of fundamentals and harmonics, are easily derived graphically and understood intuitively. Others, more complex, do not have com-

⁴ A transfer characteristic is a graph which plots instantaneous response against instantaneous stimulus. For example, the transfer characteristic of a vacuum tube is normally plotted as output plate current vs. stimulating grid voltage; of a pickup, output voltage vs. stimulating velocity, etc.

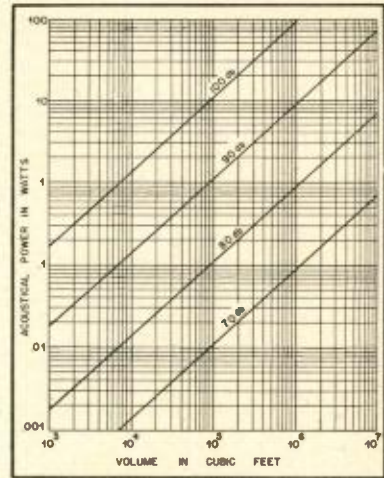

Fig. 8-7. Acoustical power required to create sound and intensity levels of 70 to 100 db. To convert to electrical power, divide by efficiency of the loudspeaker.

ponents that appear quite as obvious. For example, the wave form that results from combining, in a linear system, signals of 940 cps, 1000 cps, and 1060 cps is a 1000-cps wave, amplitude modulated at 60 cps. It is a little difficult to see 940 cps and 1060 cps in this last wave form, but an application of the principles of beat phenomena will indicate that every one-sixtieth of a second the phase of the 940-cps signal will have advanced, and the phase of the 1060-cps signal will have retreated, by 360 deg. relative to the 1000-cps signal. The three signals thus return to the same phase relationship every sixtieth of a second, and a 1000-cps wave pulsating in amplitude at the rate of 60 cps implies the existence of the two sum and difference frequencies, which are called *sidebands* in r.f. parlance. (It must be emphasized that this modulated wave form does *not* result from mixing 60 and 1000 cps in a linear system.⁵ The reference to beat phenomena is used here to indicate how an amplitude modulated wave implies the existence of sideband components, and not to explain intermodulation, which is *not* a beat phenomenon.)

When the amplitude modulated wave form of Fig. 8-5 is created through non-linear distortion, therefore, two new sideband frequencies are also created. If the input signals of Fig. 8-4 are 60 and 1000 cps,⁶ the output will contain, in addition to these two frequencies, the intermodulation products 940 and 1060 cps. Both are discordant to 1000 cps.

When the amplitude distortion is such that the positive and negative halves of the cycle are symmetrical (odd orders of harmonics), the complete

[Continued on page 60]

⁵ It is this fact which makes it necessary to operate the heterodyning "mixer" stage of a super-het receiver in Class C.

⁶ These two frequencies are harmonically related; 1000 cps is the tenth harmonic of 100 cps, which is separated from 60 cps by a musical interval of a major sixth.

AM STATIONS			
MAXIMUM HARMONIC DISTORTION AT LESS THAN 84% MODULATION	MAXIMUM HARMONIC DISTORTION 85% TO 95% MODULATION	MAXIMUM HUM AND NOISE, 150-5000 cps	MAXIMUM HUM AND NOISE, OTHER FREDS.
5%	7.5%	50 db BELOW MAX. AUDIO OUTPUT	40 db BELOW MAX. AUDIO OUTPUT
FM STATIONS			
MAXIMUM HARMONIC DISTORTION 50-100 cps	MAXIMUM HARMONIC DISTORTION 100-7500 cps	MAXIMUM HARMONIC DISTORTION 7500-15000 cps	MAXIMUM HUM AND NOISE, 50-15000 cps
3.5%	2.5%	3%	60 db BELOW MAX. AUDIO OUT.

Fig. 8-6. Maximum harmonic distortion and noise permitted broadcast stations by the FCC.

The Great Loudspeaker Mystery

H. A. HARTLEY*

An exercise in Metaphysical Philosophy

A YEAR OR TWO AGO there appeared in a certain British technical journal an article by a loudspeaker manufacturer concerning the design of loudspeaker diaphragms. In it, there appeared the old platitude that the perfect diaphragm was a rigid piston of negligible mass. From this premise it was argued that since the perfect diaphragm could not exist, attempts should be made in practical work to approach this perfect concept as closely as possible. Therefore . . . and so on.

Now it so happens that I have never been particularly attracted by this notion of the perfect diaphragm, so I wrote a letter for the correspondence columns of the journal in question, the burthen of which was that the idea that the perfect diaphragm should be an infinitely rigid piston was nonsense, because, I went on to say, if the diaphragm were infinitely rigid it could produce only one frequency at a time—in other words it could reproduce only a sine wave. The editor's technical adviser wrote a private letter to me to ask if this letter of mine was a leg-pull, for if they were to take me at my word, the publication of my letter would make me the laughing stock of the audio industry of Britain. I said that it wasn't, and that I was quite ready to stand by the consequences of my letter being published, and would they please publish it? They did not, and I have never been able to determine whether it was done out of kindness to me or out of consideration for themselves. During a recent visit to New York I mentioned this incident to *your* editor, and he looked at me in a quizzical sort of way, not quite sure whether I was pulling his leg, or whether I had got something. I threatened him with a full thesis on the matter, and here it is. You have my assurance that it is a serious contribution to audio thinking, and I am prepared to abide by the consequences of putting my name to a major heresy.

Let us get the problem clearly stated. It is the conventional idea that the perfect speaker diaphragm should be an infinitely rigid disc, preferably of no mass. It is my idea that the perfect speaker diaphragm should be a flexible entity (shape not specified) which in its various parts vibrates in various ways so that the over-all effect is to reproduce all frequencies with constant output. The problem is therefore: Which is correct? I shall try to help you solve the mystery.

Logic vs. Mathematics

There has been some feeling that the articles in *Æ* should butter the popcorn. If this can be done without spoiling their authenticity I am all for it. Mathematical treatment of loudspeakers is not easy and can be so difficult as to be impossible in certain directions. I believe that my thesis

can be comprehensive without being mathematical. Those readers who would like to have an extremely able exposition of the mathematical analysis of loudspeaker behavior are recommended to study the book "Loud Speakers" by N. W. McLachlan. I warn them that it calls for mathematical knowledge of a high order, and that is why I have considered my treatment should be rather one of non-mathematical logical thought. However, the technical statements I make are provable by rigorous mathematical processes.

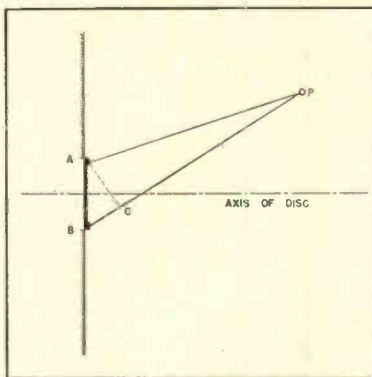

Fig. 1. Representation of a circular disc, AB, in a rigid baffle to show the cancellation due to phase distortion when the listener, P, is not on the axis of the disc.

My argument comes in the domain of metaphysics, and I hasten to add that metaphysics has nothing to do with mysticism. It is characteristically anti-metaphysical to suppose that this science of thought processes has anything to do with psychology, theology, or demonology. It is an exact science, concerned with the examination of thought, argument, and knowledge.

It is an axiom of metaphysical philosophy that argument based on opposing absolute presuppositions can never be resolved. If you and I start arguing in a general sort of way as to what is the most nearly perfect diaphragm for a speaker, and you say "The cone must be made as stiff as possible" and I retort that that is all wrong, we can argue about this until all is blue without getting any further because we hold conflicting presuppositions. Every statement made by a man is, consciously or otherwise, an answer to a question, and the question has arisen out of some earlier statement which in turn derived from another question. The metaphysician traces these statements and questions back to their source until he arrives at something which is not susceptible to logical treatment. That "bit of knowledge" when examined is found to be a matter of belief, not knowledge, and he calls it an "absolute presupposition" because it is the absolute source of your subsequent argument. He does not attempt to criticise the

validity of your absolute presupposition, but he will unerringly point out any flaw in the logical development of your argument based on it.

On this basis let us consider the problem I have put to you. The statement that the perfect speaker diaphragm should be an infinitely rigid disc of no weight is an absolute presupposition, because it is an article of faith. How can it be otherwise? It is clearly impossible for any person to produce an infinitely rigid disc of no weight, so why call for an abstraction as the goal, except as an act of faith? But if we seek to find a *reason* for the common acceptance of a hypothetical device as the aim of all speaker designers, then the search is a short one, for the mathematicians will tell you that whereas analysis of the behavior of a disc *in vacuo* is comparatively easy, it has not yet been found possible to analyze the behavior of a cone. If, therefore, mathematical treatment is not available for this case it passes out of the realm of exact science, and there must be substituted something which can be analyzed mathematically, and that is the disc.

Now it can also be proved mathematically that under the impulse of a voice coil actuated by alternating currents the disc will distort in a way which can be exactly foretold without experiment. If, therefore, we are conscious that the disc in practice does distort, we easily pass on, or back, to the supposition that the disc, to be perfect, should not distort, and to achieve that it must be rigid. By the same process, but by different mathematical treatment, it can be proved that transient reproduction is differentially distorted the greater the mass of the disc, and the perfect diaphragm should also have no weight. And so you are back to your absolute presupposition, which, as I have pointed out, is not a matter of scientific knowledge but of faith. And I am entitled to disagree with your faith, even if I accept your facts.

But, I can imagine you saying, what am I getting at? On the one hand I admit that mathematics proves that a practical disc distorts, but a theoretical rigid disc would not distort, and mathematics also proves that a practical disc having mass also distorts, and by inference a theoretical massless disc would not distort. On the other hand I am obviously not satisfied with the idea that the perfect disc, infinitely rigid and infinitely light, which can be mathematically proved not to distort, is the ideal to which, in an imperfect world, we can only approximate to. Am I just being difficult? The statement made above would probably be acceptable without careful thought, but it contains two serious flaws in logical argument.

First is the assumption that if it can be mathematically proved that a non-rigid disc must distort, it follows that a rigid disc will not distort; and that a disc with mass hav-

* 152, Hammersmith Road, London W. 6, England.

ing been proved to distort transients, it follows that a massless disc will not. The second is the assumption that there is no other form of distortion accompanying the use of a rigid massless disc. Both these assumptions are wrong, as can be proved mathematically. Let us take only two examples of the latter's wrongness.

In Fig. 1, AB represents a rigid circular disc mounted in an infinite rigid baffle. P is a point off the axis of the disc, a position such as might be taken by any listener to a speaker. Now P is nearer to A than to B and the radiation from B will be out of phase with that from A by an amount $2\pi(BC)/\lambda$, where BC is the difference in the two distances and λ is the wavelength of the radiation. At low frequencies BC is small compared with λ , and the phase difference is negligible; but at high frequencies λ may be larger than BC with consequent considerable phase distortion. Specifically, if $BC = \frac{1}{2}\lambda$ the radiation from A and B will be in opposite phase, and cancellation of the radiation will occur.

This can be translated into the form of a polar radiation curve. If the phase difference effect is not noticeable at low frequencies it can be assumed that the polar curve for a low frequency would be semi-circular, and that the radiation would be hemispherical; mathematically treated it can be shown that at, say, a frequency of 4000 cps the polar curve will be an ellipse and the radiation ellipsoidal. Worse, the larger the disc the narrower the ellipse; and a little reflection will show that this must be the case, since the difference between PA and PB will be greater, the larger the disc. Since it is the purpose of a loudspeaker (and its diaphragm) to radiate sound as well as possible, one can naturally suppose that the radiation should be hemispherical at all frequencies, but we have just seen that the rigid disc is inherently incapable of achieving this.

The Flexible Disc

If the mathematical analysis be carried some stages further to examine the behavior of a flexible disc, one which develops nodes under the impulse of an electric current applied to the voice coil, we find that the polar curves at high frequencies are much better than those of a rigid disc, and again some reflection will indicate why this should be so, for in my figure B may be on a node and A at an antinode, thus reducing the difference between PA and PB.

Our metaphysician may now be allowed to say a few more words. He did not quarrel with your absolute presupposition that a rigid massless disc was the theoretically perfect diaphragm, because he showed that that was a matter of belief, and you are entitled to believe what you like; but you are now under an obligation, if you insist on adopting the scientific way of thinking, to find out if there are any grounds for your belief, and I have just shown that there are not. I am not prepared to accept the excuse that you believe your perfect disc is the best compromise, for science has no room for compromises—a thing or a thought either is or it isn't. But it has been truly pointed out by no less a savant than the late Professor R. G. Collingwood that people are very touchy about their absolute

presuppositions, so I shall not labor the point. I shall content myself by observing that the belief that a massless disc is the perfect diaphragm has no justification either in theory or practice.

And now, if I may, I should like to put my second cat among the pigeons—my argument that if the perfect diaphragm, the infinitely rigid disc of no weight, could be made, it could only reproduce a sine wave. I am afraid that when we enter this field of speculation we cannot have confirmation from mathematics, for the problems are so complex as to defy analysis. Our speculation can only be philosophical, and we can only accept what appears to be the more reasonable theory. Let us examine this notion of mine.

A rigid disc is inflexible. If vibrations can be transmitted through it then it is flexible. Since it is rigid it can only act as a pure piston incapable of being deformed. Apply a sine-wave to it through the medium of the voice-coil and former of any frequency you like, say 100 cps. The disc, being a suspended diaphragm, vibrates to-and-fro at that frequency. Now, while continuing to cause it to vibrate at 100 cps, you also apply another frequency of, say, 200 cps. What will happen? Since it is your supposed perfect diaphragm it will reproduce both frequencies at amplitudes strictly proportional to the amplitudes of the applied currents, but how can it do this? Since it is infinitely rigid it cannot vibrate in one part at 100 cps and in another part at 200 cps so the only possible theory is that it moves forwards and backwards non-sinusoidally, the form of its movement being the counterpart of the harmonic sum of the two separate frequencies. This also involves the acceptance of the consequence that the movement of the diaphragm includes accelerations and decelerations with each half-cycle. I agree that if the diaphragm has no mass it could perform in this way, but only *in vacuo*, for in air the air friction would be enough to cause distortion of the necessary accelerations and decelerations. This implies that the definition of the perfect diaphragm being an infinitely rigid disc of no mass must also be restricted to the condition *in vacuo*, but this makes nonsense of the whole idea, for without air we cannot hear sound, and without sound output the perfect diaphragm is useless.

But the perfect piston protagonist has another headache coming. We have seen that his belief necessitates the diaphragm moving forwards and backwards in a non-sinusoidal manner exactly reproducing the non-sinusoidal current applied to the voice-coil. Forgetting the *in vacuo* restriction, a fatal snag, we have to envisage the piston moving forwards and backwards reproducing the fantastically complex waveform of a full orchestra by vibrating to-and-fro with hundreds, possibly thousands, of accelerations and decelerations in a tiny fraction of a split second. Is this conceivably possible? And if it is, how can it, having escaped the air friction, transmit this extraordinarily complicated waveform to an elastic medium like air, which will initially absorb all the fine detail long before it has a chance of being propagated? As we must expect the perfect diaphragm to reproduce all the frequencies applied to it, it is clearly

impossible for it to do so by complex oscillation to-and-fro, so whether my statement that the infinitely rigid disc could only produce a sine-wave is true or not, the chances are overwhelmingly in its favor that it is true and it certainly cannot be proved wrong. We have also seen that the rigid disc cannot be perfect by its very nature, so it seems time that the whole of this absolute presupposition can be jettisoned. It follows that all the theoretical ideas based on this presupposition must also be thrown out. In short I am constrained to follow the late Henry Ford's example when he spoke of history and say that all conventional loudspeaker design of a theoretical nature is bunk.

"Design" of Speakers

How, then, you may well ask, how does one design loud speakers?

I invite you now to consider my absolute presupposition, which is that the perfect diaphragm is a flexible entity which vibrates in various sorts of ways so that the sum total of its performance is to reproduce all the frequencies imparted to it by the current applied to the voice-coil by imparting movement to various zones of air so that the ultimate sound-waves impressed on the listener's ears create a sensation exactly similar to that created by listening to the original performance. This rather complicated sentence carries within it an inferential absolute presupposition—that you cannot design speakers by any mathematical process, since analysis of the process is beyond human knowledge. I have already explained how even high-grade mathematics can only undertake what are really the simplest phenomena, and then only suppositional cases, for, in general, the formulas developed presuppose conditions which are not met with in actual practice.

There is a good deal of justification for accepting my absolute presupposition as an article of faith (for it is nothing more) and using it as a basis for a logical development of argument. Consider, for example, a musical instrument such as a violin.

It is an ordinary commonplace scientific fact that the fundamental frequency of the note produced by drawing the bow across the string is a function of the length of the string between the bridge and the performer's applied finger. Whether the performer is a virtuoso or a tyro, provided the distance is x inches the frequency of the note will be y cps. But in practice the quality of the note (of given frequency) depends on at least two things, one the way in which the bow is drawn across the string, the other the nature of the body or belly of the instrument. It requires no great musical knowledge to be able to hear the difference between the sawing of the beginner and the polished perfection of the great violinist. It is not just a matter of producing the right notes at the right moment—sheer practice in manual dexterity will in time produce this result—but more important is the nature of the sound produced, and that depends on bowing. But the expert is not content with this; he will try to obtain a specimen of the work of an Amati or a Stradivari so that his fingering and his bowing will not be spoiled by poor instrumental tone. When all this has been

[Continued on page 53]

IT MAKES Good Sound... AND Good Sense, TOO

You buy good records so you can enjoy good sound. You fondle these records, and handle them ever so gently, because you know that once the surfaces are marred, the quality will be gone to you forever.

You must realize then, that your record changer becomes an all-important factor in the matter of record quality. It must treat with your records even more gently than you could yourself, and it must contribute nothing which might impair the quality of the sound. Its tone arm must track at

light stylus pressures and with free lateral compliance to protect the groove walls from wear.

Its speed must be constant for correctness of pitch, and to avoid 'wow'. It must be free from rumble, and from audible resonances. It must retain and reproduce all of the quality in the record, protect it for future plays, and it must contribute no distortions of its own.

In the light of these requirements, examine the features of the COLLARO, and see if they don't meet all the exacting specifications that make this

The High Fidelity Record Changer for High Fidelity Reproduction

Model 3/522—Fully Automatic Intermix Model

List Price.....\$65.00

Model 3/521—Fully Automatic Non-Intermix Model

List Price.....\$54.50



ONLY THE Collaro INTERMIX 3/522 HAS ALL THESE HIGH FIDELITY FEATURES:

- Intermixes 10 and 12 inch Records at All Speeds.
- Steady, Constant Speeds—No Rumble or Wow.
- Weighted, Rubber-matted, Rim-driven Turntable.
- Four Pole Motor with Self-aligning Oilite Bearings.
- No Hum Pickup.
- Molded Rubber Drives—No Belts to Slip or Replace.
- Automatic Muting Switch.
- Stylus Pressure Adjustment—Tracks at as little as 3 grams.
- Absolutely Jam-proof Operation.
- Ball-bearing Mounted Turntable and Tone Arm.
- Automatic Shut-off after Last Record.
- Tone Arm Clamp for Portable Applications.
- Base Dimensions: 14 3/4" x 12 1/4"
- Depth Below Base: 2 1/2"

Complete Service and Replacement Facilities Maintained for your Convenience.



Record Player 3-Speed Model 3/514 List Price \$33.60

Model 3/522
Collaro
Fully Automatic INTERMIX
3-SPEED RECORD CHANGER

FOR 7, 10, AND 12 INCH RECORDS

At Leading Distributors, or Write for Literature.

ROCKBAR CORPORATION
211 EAST 37th STREET • NEW YORK 16, N. Y.

The Protection of Ideas

ALBERT WOODRUFF GRAY*

Legal aspects of creative thought are also important to engineers.

THE SUGGESTION for an improvement in radio cabinets, accompanied by sketches of the proposed innovation was submitted to a radio manufacturer by a firm of cabinet designers. Later the sketches were returned by the manufacturer with a letter that it was not interested but should any of the designs be used, payment would be made on a royalty basis of 1 per cent of the cost of the cabinet, to be paid by the cabinet manufacturer.

The sketches submitted by these cabinet designers to the radio manufacturer had no earmarks by which the designers might identify the plans as their own. When later these same features appeared in a cabinet produced by this manufacturer, suit was brought by the designers for the value of the plans they had submitted.

The defense of the company, which the court sustained, was that the design incorporated in these cabinets was conceived by the president of the company from the suggestion of an automobile hood and that at no time had he ever had any knowledge of the ideas or suggestions submitted by these designers.

Nearly two hundred years before this incident an English judge said in the decision of a case involving the exploitation of ideas,

"Nothing can be the object of property that is not capable of distinguishable proprietary marks. The principle of this first institution of property was established to preserve the peace of mankind which could not exist in a promiscuous scramble. Therefore a moral obligation rests on all that none should intrude upon the possessions of another.

"But this obligation could only take place where the property was distinguishable and everybody knew that it was not open to another. The breach of a duty must be willful to make it criminal. It was necessary therefore that every person should have some indicia, some distinguishing marks upon his property to denote his being the proprietor, for hard would be the law that should judge a man guilty of a crime when he had no possibility of knowing that he was doing the least wrong to any individual.

"Now where are the indicia or distinguishing marks of ideas," asked that eighteenth century English judge. "What distinguishing marks can a man fix upon a set of intellectual ideas so as to call himself the proprietor of them? They have no earmarks upon them, no tokens of a particular proprietor."

There was lacking in these radio cabinet designs the earmarks or indicia, mentioned in that English decision, that

would have aided them in the support of their claim for compensation, had the ideas for this innovation been submitted under the provisions of an agreement or contract between themselves and the radio manufacturer.

This lack of means of showing the identity, the absence of the earmarks, in circumstances of this character, was the subject of a comment by the Court of Appeals in New York state, in denying recovery to the proprietor of another idea claimed by him to have been wrongfully appropriated by another.

"Without denying that there may be property in an idea or trade secret or system," said that court, "it is obvious that its originator or proprietor must himself protect it from escape or discovery. If it cannot be sold or negotiated or used without disclosure it would seem proper that some contract should guard or regulate the disclosure, otherwise it must follow the law of ideas and become the acquisition of whoever receives it."

Idea Outlined in MS.

An action before a New Jersey court involved a manuscript in which had been outlined a valuable idea but with no provision for compensation to the originator. The plan was adopted. Later when an action was brought to recover the value of this plan the court said of the recovery claimed by the author,

"He has undoubtedly the right to claim protection for his manuscript. The combination of words of which it is composed is also protected. The law has never attempted to go beyond this and to enjoin for the benefit of the author, after publication, the use of ideas contained in his work. In the case of secret processes of manufacturing the law does to a certain extent enjoin the use of ideas. In enjoining the use of formula it restrains the wrongdoer from putting the ideas formulated to practical account. The protection ends when the secret becomes known.

"If the idea contained in a patented device of 'A' suggests to the mind of 'B' another idea that would not have arisen in the mind of 'B' but for the stimulus of the prior idea, 'A' can claim no property in that, and yet 'B' has mentally appropriated 'A's' idea and made it the basis of his own; and I do not suppose it has ever been contended that the entire public are not at liberty to subject 'A's' idea to such investigation and discussion as it may desire.

"It was, as far as its originator was concerned, an idea, pure and simple. Now it has never in the absence of contract or statute, been held, as far as I am aware, that mere ideas are capable of legal ownership and protection."

In a later opinion rendered in this same litigation the New Jersey court made this supplementary comment, "Undoubtedly ideas, if valuable or even thought to be valuable, may be the subject of bargain and sale. They may be the subject of contract but they must be protected by contract."

An idea once released by publication freed for the use of whomsoever may so wish, like a wild animal freed from its cage, can be the property of no one. Substitute for a cage a contract and for the bird or beast of the outdoors, an idea, and the analogy is complete. In every instance there must be a contract, either express or implied. Lacking that the idea is irrecoverable when once it has gone from its owner.

An idea was submitted to a manufacturer who had made no agreement for payment and the outline of this idea was unaccompanied either by drawings or the findings of experimental work.

If the manufacturer derived benefit from the idea, asserted the federal court denying to the originator of this idea a recovery, it is nevertheless not indebted to this originator because it did not offer to or make any agreement to pay for such mere suggestions as the possessor of this idea made. When he voluntarily divulged his mere idea and suggestion, whatever interest he had in it became common property and was available to the manufacturer.

A contract protecting an idea against exploitation and loss must obviously precede the disclosure of the idea itself. The idea, however, must be thus protected in its disclosure but it must be novel to the recipient and of a substantial value to him.

"When information is proffered as consideration for a contract it is necessarily implied—it is indeed the essence of the proffer that the information shall be new to the one to whom it is proffered," said the Connecticut Supreme Court in its decision of a case of this character.

"A statement to one of what he already knows is not, as to him, information but merely a statement of fact already known. The imparting of information in a situation like this must involve an active process, resulting in arousing or suggesting ideas or notions not before existent in the minds of the recipient, otherwise it is not information in the true sense of the term, although it may be a statement of fact."

In Indiana some years ago an idea or scheme was submitted with a letter that said, in substance, that the plan was submitted for approval. This was followed by an outline of the scheme and the letter concluded with, "I trust that this idea

[Continued on page 51]

* 3536 76th St., Jackson Heights, N. Y.

★ America's Finest Home Music Amplifiers ★

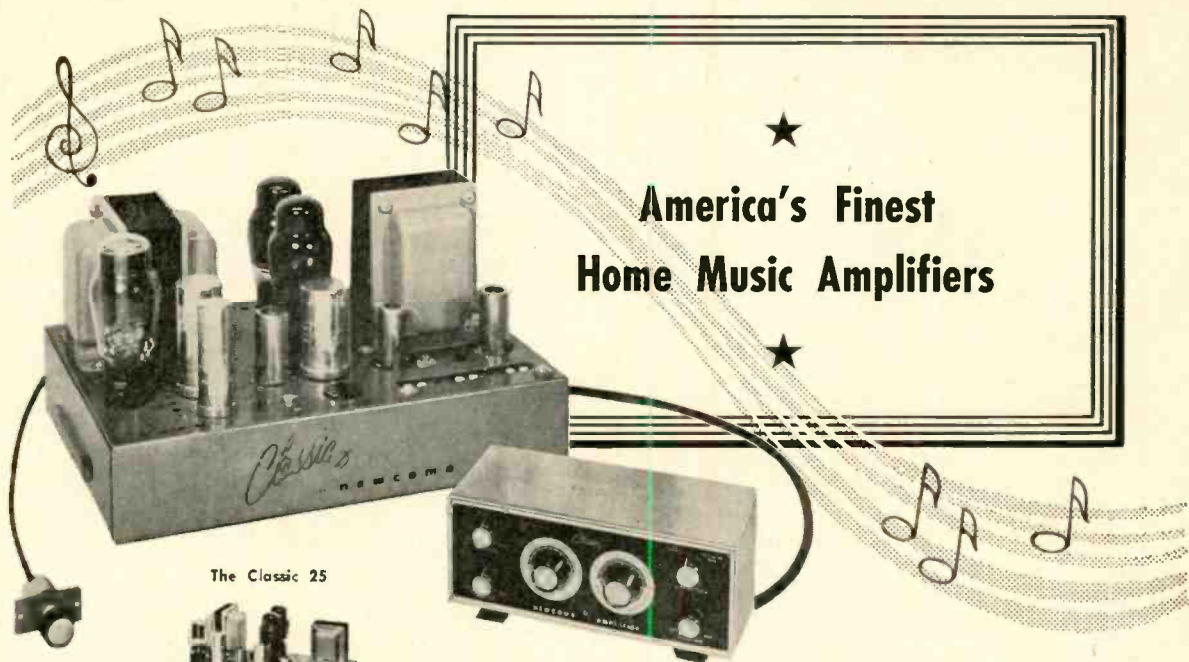

The Classic 25



The Classic 15



Model A-15



Model A-104R



Model A-104



Model AM-10R



Model AM-10



Model A-10

modern classics in sound by newcomb

Music lovers are discovering a new world of musical enjoyment, actually hearing whole octaves more music from their own favorite recordings, with custom home music systems built around these remarkable new amplifiers. Exclusive new developments make them sound better, simpler to operate and easier to install.

THE CLASSIC 25. There is nothing, short of live music itself, to compare with the brilliant, clear, full-bodied tones of this latest 25-watt amplifier. Distortion has been reduced to the practical limits of measurement to make it the lowest distortion producing element in the entire process of reproduction from original recording to your speaker, yet reserve power has not been sacrificed. Unique tone curves insure utmost realism and true bass. "Audi-balance" feature balances output tubes in seconds to insure a consistency of performance previously impossible. "Adjusta-panel" device extends control shafts instantly for cabinet mounting. There are 6 inputs for radio, TV, tape, crystal and magnetic (2) pickups. "Fletcher-Munson" compensated volume control maintains perfect aural balance. Crossover selector simplifies attainment of correct playback response, includes foreign and domestic frequencies as well as the new A.E.S. standard, provides automatic microgroove level correction. 5 position record condition compensator controls surface noise. The beautifully finished, complete remote control permits substantial installation savings. The savings in cabinetry and labor can easily amount to more than the cost of this superb amplifier.

THE CLASSIC 15. This 15-watt model permits the same installation economies as the Classic 25 with many of its luxury features, including "Adjusta-panel," "Audi-balance," crossover selector, and the beautiful, complete remote

control. 6 inputs. ± 1 db 10 to 25,000 cycles. 15 watts at less than 1% distortion.

MODEL A-15. 15 watts. Similar to Classic 15 in most particulars without remote control. "Adjusta-panel" feature extends control shafts up to $\frac{3}{4}$ " for convenience in cabinet mounting.

MODEL A-104R. A value packed 12-watt (2%), 10 watts (1%) amplifier ± 1 db 20 to 20,000 cycles. Features response to 100 kc, remote control for easier installation, record crossover selector with A.E.S. position, built in pre-amp, Fletcher-Munson compensation, separate bass and treble controls, "Adjusta-panel" mounting.

MODEL A-104. Identical to A-104R without remote. Has "Adjusta-panel" for easy installation.

MODEL AM-10R. A low cost 10-watt remote control amplifier. ± 1 db 20 to 20,000 cycles. Built in pre-amp. A.E.S. or standard playback curves. "Adjusta-panel" mounting. Dual tone controls. New "Interlocked" circuit. Extremely easy to install.

MODEL AM-10. Identical to AM-10R without remote. Has "Adjusta-panel" feature for easy installation.

MODEL A-10. Essentially similar to AM-10 without pre-amp. Designed for crystal pickups. Includes "Adjusta-panel." Write for catalog of all 8 completely new amplifiers priced from \$39.50 to \$269.50 audiophile net.

Newcomb
15 years of quality leadership
DEPT. T, 6824 LEXINGTON AVE., HOLLYWOOD 28, CALIFORNIA



The Audio Fair—Los Angeles

Well on its way toward topping the New York Audio Fairs in attendance and number of exhibitors, this newest of showings will play host to many who have been unable to attend the Eastern exhibits.

IT IS SAID about one state in the Union that whatever anyone else does, they do it better. And it is beginning to appear that this same statement might also be applied to the audio industry in Southern California, for the first Audio Fair—Los Angeles seems slated to come a very close second to the 1952 Audio Fair in New York—if it doesn't top the Eastern event, which it could well do.

February 5, 6, and 7 are the dates, and the Alexandria Hotel in Los Angeles is the place. The entire audio industry will supply the "who" unless the attendance should be entitled to that distinction. And those who have ever attended an Audio Fair know what is in store for the Alexandria for those three days—never a dull (or quiet) moment.

The Alexandria Hotel—one of Los Angeles' older and most aristocratic hotels of earlier days—is admirably suited for the Audio Fair. The rooms are large and the ceilings are high, which offers ideal listening conditions for audio equipment. The hotel is located in downtown Los Angeles, and is easily accessible from any part of the great metropolitan area.

The exhibits will feature custom high-fidelity television, home-music systems, and associated components, along with stereophonic and binaural demonstrations, and will be open to the public at no charge. According to Cap Kierulff, publicity director for the Audio Fair—Los Angeles, approximately 100 exhibitors will demonstrate their latest products which are now coming off the production lines to meet the increased consumer demand for higher quality radio-phonograph reproduction and for cus-

tom-built home entertainment centers. Exhibits will be open from 1:00 p.m. to 9:00 p.m. each of the three days, and will be located on the 6th and 7th floors of the hotel.

Hi-Fi Installations

Engineers, architects, contractors, and the home owner will see demonstrated the manner in which record changers and radio-phonographs, with their associated loudspeakers and cabinets, can be integrated into the design of walls, ceiling, and furniture; how all electronic equipment and components, including cable, can be installed to match the decor of any room, yet maintain an ease of accessibility for rapid servicing.

Educators and industry will see and hear the latest in public-address control facilities. Pre-recorded educational tapes, reproduced on the latest commercial and professional tape recorders, will be in actual operation, as will be new designs of record and transcription players, microphones, FM-AM-TV tuners, remote-controlled amplifiers, and corner loudspeaker enclosures.

Evidence of the trend toward high-fidelity reproduction of recorded and broadcast programs in the home, office, school, and club is reflected in the fact that the recent Audio Fair in New York drew over 13,000 spectator-listeners. Further evidence is in the fact that high-fidelity phonograph records have found a national market which is being well serviced by thousands of specialty dealers from coast to coast—catering to more and more consumers who desire near perfection in audio reproduction equipment, the only means by which they can achieve true listening pleasure.

Industry Advisory Committee

Recognizing the potential growth of High Fidelity Audio for home sound reproduction, youthful William L. Cara organized an industry Advisory Committee of some 14 members, and has developed the Audio Fair—Los Angeles into an attraction which will satisfy the growing need for the consumer and dealer to investigate all available top-quality audio equipment under one roof—with the added advantage of being able to hear as well as see the equipment in operation.

The Advisory Committee is composed of Boyd McKnight, chairman of the Los Angeles Section of the AES; manufacturers Robert Newcomb of Newcomb Audio Products Co. and William Thomas of James B. Lansing Sound, Inc.; Representatives George Davis, Richard Hastings, Frank Koessler (Neely Enterprises), Lee Owens, and George Tivy; distributors Harry Braverman of Universal Radio Supply Co., James Pelham of Figart's Radio Supply Co., and Harry Shaffer of Hollywood Electronics; and publicity director Cap Kierulff, of Kierulff Sound Corp.

One feature of the show will be the selection of "Miss Audio Fair—Los Angeles." The accompanying photo shows candidate No. 1, Miss Gina Lund, with several members of the advisory committee.

Technical Sessions

The Los Angeles Section of the Audio Engineering Society has scheduled approximately 20 papers to be given during the three days of the Fair. Among them are the following, which are only representative of the subjects to be covered:

- "FM Carrier Magnetic Sound System," by John T. Mullin, Bing Crosby Enterprises.
- "Motor Drive Systems," by Olin L. Dupy, Metro-Goldwyn-Mayer Studios.
- "Structure and Performance of Magnetic Transducer Heads," by Otto Kornei, Brush Development Co.
- "Use of Electrical Delay Lines in Studies of Binaural Hearing," by R. S. Gales and R. G. Klumpp, U. S. Navy Electronics Laboratory.
- "The Disc Recording Characteristic," by E. H. Uecke, Capitol Records, Inc.
- "Aircraft Public Address System Operation Under High Level Ambient Noise Conditions," by J. C. Baker, Lockheed Aircraft Co.
- "History and Development of Stereophonic Sound Recording," by R. H. Snyder, Ampex Electric Corp.

While the complete list of papers to be presented is not available at press time, Allan L. Wolff, chairman of the AES Papers Committee, West Coast, has indicated that there will be a full program of technical papers, and the Society plans to publish the entire text of all of the papers as soon as possible after the Fair.

The Los Angeles Section of the Society is sponsoring the show as part of its service to the industry.



Some of the members of the Industry Advisory Committee list the qualifications of Gina Lund, candidate No. 1 for the title of Miss Audio Fair—Los Angeles. Left to right—Robert Newcomb, James Pelham, Miss Lund, Bill Thomas, Boyd McKnight, and Fair Manager Bill Cara.

presto change-o

If you're *not* using Presto discs at present, then it's time for a change. The reason, in one word . . . quality! From the meticulous preparation of the aluminum base in the Presto plant to the final play-back in the studio, quality is the byword . . . your assurance of consistent performance, unmatched fidelity of reproduction, long service. That's why Presto is the proven leader in the professional disc field . . . a leader that merits your consideration when you decide that it's time for a change . . . right now.



PRESTO
RECORDING CORPORATION
Paramus, New Jersey

Export Division: 25 Warren Street, New York 7, N. Y.

Canadian Division: Walter P. Downs, Ltd.,
Dominion Square Bldg., Montreal

WORLD'S LARGEST MANUFACTURER OF PRECISION RECORDING EQUIPMENT AND DISCS

Making the Best of an Audio Transformer

N. H. CROWHURST*

A discussion of the effect of the various characteristics of a transformer on its performance. Curves are shown for low- and high-frequency performance of both input and interstage transformers.

THE PREVIOUS ARTICLES have clarified the properties of audio transformers bearing on its performance, and shown how the electrical properties of an individual specimen can be measured up. To make the best use of this information, charts have been devised to simplify prediction of performance, and adjustment of circuit values for optimum.

In any audio circuit, frequency response is usually considered first. Generally it is desirable that this should be as flat as possible for as wide a frequency range as possible, but sometimes deliberate narrowing of the band or correction for deficiencies elsewhere is required. The charts here given enable any of these requirements to be met with the minimum of effort.

Low-Frequency Response

Treatment of this end of the spectrum falls into two groups, as explained in the first article:¹ (1) direct-coupled transformers, either single ended or push-pull; and (2) parallel-fed transformers.

The treatment for direct-coupled transformers is simple, as previously explained. The response is generally of the form shown in Fig. 3. of the first article (reproduced here as Fig. A), the 3-db point on this curve being found by equating the reactance of the primary inductance to the total shunt resistive impedance, consisting of the input impedance or plate resistance of the tube, in parallel with the referred secondary load resistance and the resistive component of magnetizing current. To adjust this l.f. cut-off frequency, any of these impedances, or the primary inductance, may be altered to produce the desired result. Plate resistance can be modified by the use of feedback. The load resistance may be fixed, but in some applications, such as input and interstage transformers, resistance shunted across the secondary is not regarded as a load, and may be adjusted to suit response requirements. The primary inductance can be modified by adjusting the air gap, or by altering the d.c. polarizing through the primary, in the case of single-ended interstage transformers.

* 82, Canterbury Grove, London, S. E. 27.
¹ N. H. Crowhurst, "How good is an audio transformer?" AUDIO ENGINEERING, March, 1952.

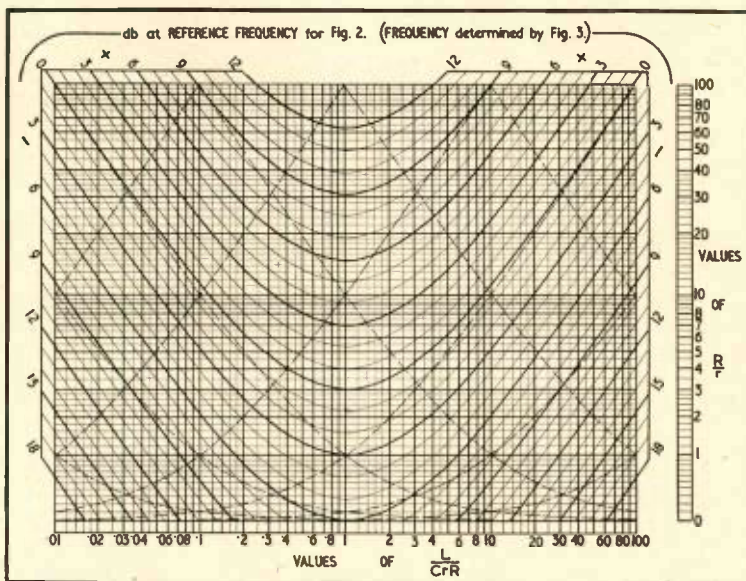

Fig. 1. Chart for determining response shaping from known values of L, C, r, and R (for significance of which see text); and for estimating effect of varying circuit values.

In direct-coupled transformers where d.c. polarizing is present, the inductance of the primary is reasonably constant, and the response curve follows the shape of Fig. A quite closely. But where there is no d.c. polarizing, and the transformer is cored up without an air gap, the primary inductance changes quite considerably with both amplitude and frequency, so the shape will not conform at all closely to this response. However, in these cases the l.f. response is usually made better than minimum requirements at all levels, so that its exact shape at any level is unimportant.

When using parallel-fed transformers the treatment is somewhat different. The l.f. cut-off network is analogous to a tuned circuit, and the shape of the response depends on the degree of damping present, series and shunt. Here again the primary inductance value is likely to vary with level and frequency, unless a component with a gapped core is used, so accurate prediction is rendered difficult. For this reason charts specifically for l.f. response prediction are not included, but those provided for h.f. response prediction are made adaptable for l.f. as well, where required. When using

the charts for working out a suitable l.f. response, the frequency scale of Fig. 2 is reversed.

Although selection of conditions resulting in critical damping, or even a small degree of peaking, has been known, for the purpose of extending the l.f. range, it is not to be recommended for the reason that response will vary with signal level. On the other hand, when space or cost is restricted, it will be found that use of a coupling capacitor larger than an optimum value for critical performance, will deteriorate the l.f. response, rather than improve it.

High-Frequency Response

Variable inductances do not make the job so difficult at this end. Leakage inductance is constant, so quite accurate prediction is possible.

In Figs. 1 and 3, r always stands for the impedance connected to the low-impedance winding, and R for that connected to the high winding. So in step-up transformers, such as input or interstage, r is the input impedance or plate resistance in parallel with the coupling resistor, and R is the referred secondary shunt resistance.

Everybody's Talking-

about the
sensational new
1953
Hi-Fidelity

PILOTUNER

FM-AM TUNER



MODEL AF-821A

Behind this brilliant new Tuner stands Pilot's 53-year-old, world-wide reputation for producing the most advanced communications instruments that science has yet developed. Once enjoyed only by a select circle of engineers "in-the-know" . . . Pilot sensitivity, selectivity, stability — are now yours, in this incomparable new PILOTUNER. No better tuner can be made at any price . . . yet the Pilotuner is modest in cost, at \$99.95



Built by
PILOT RADIO CORP.
the name that has been a
by-word for the greatest in
precision communications
equipment since 1919.



PILOTONE Amplifier Model AA-901

Designed for high fidelity audio reproduction from phonograph, AM or FM radio, television or microphone input. Full Williamson circuit. A supreme amplifier with traditional Pilot quality. Priced at \$99.50

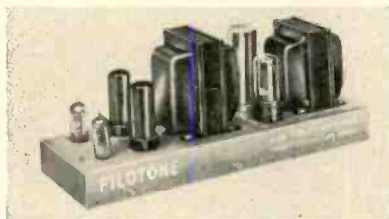

PILOTONE Amplifier Model AA-902

A compact, medium price, high fidelity unit for use where cabinet or other mounting space is limited. Can be operated with PILOTUNER model AF-821 and similar tuners for FM-AM radio, television or phonograph reproduction . . . \$42.50

NEW! High-Fidelity PILOTONE AMPLIFIERS and PRE-AMPLIFIER



PILOTONE Pre-Amplifier Model PA-911

A companion unit for Pilotone Amplifier Model AA-901 . . . built up to the same exacting standards. Selector switch allows quick choice of auxiliary, TV, radio or phono inputs. Handsome in appearance, unsurpassed in performance. Exceptionally low priced at . . . \$29.95

Write Dept. AE-1 for free descriptive literature

PILOT Radio Corporation • 37-06 36th Street, Long Island City, New York

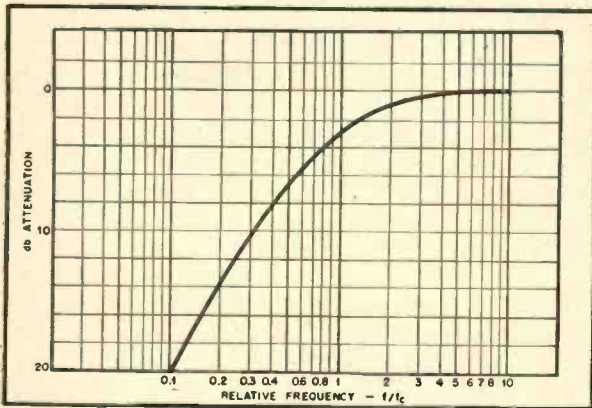
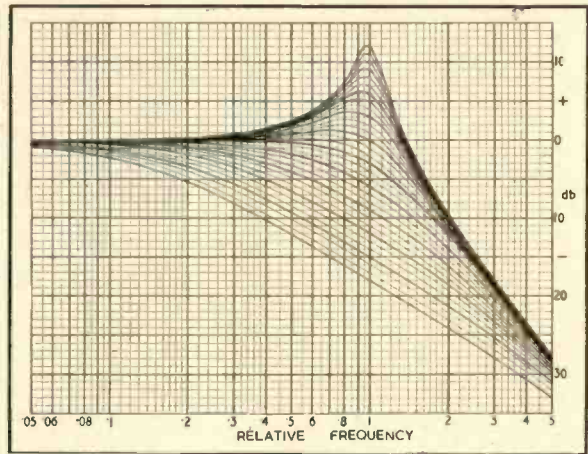

Fig. A. (above) Low frequency cut-off attenuation characteristic, 6 db per octave. Fig. 2. (right) Showing the possible variations of response shaping. The shape applicable to a particular case is determined by the Chart of Fig. 1.



To apply the charts to l.f. responses, r is the parallel combination of the tube plate resistance and its coupling resistor, and R is the parallel combination of all shunt resistance components after the coupling capacitor, referred to the primary.

Output transformers employ a step-down ratio, so R becomes the source impedance of the plate circuit, and r is the load resistance referred to the primary.

For h.f. circuits, L is the leakage inductance referred to the appropriate winding, and C is the total shunt capacitance "seen" by the high winding, including its own self-capacitance, referred to the same winding as everything else.

For l.f. circuits, L is the primary inductance, and C the coupling capacitor value.

To use the charts, values of r and R are assumed, L will be fixed by the transformer itself, and C will have a minimum value fixed by the transformer and its associated circuit. From these values the quantities L/CrR , R/r , and LC are evaluated (L in henries, C in farads, r and R in ohms). The chart of Fig. 1 is then used to locate the shape of the response among those shown in Fig. 2, and the chart of Fig. 3 locates its position on the frequency scale.

The right half of Fig. 3 applies to h.f. cut-offs and the left half to l.f. circuits. Figure 1 finds the db response at the frequency given by Fig. 3, which is marked 1 on the RELATIVE FREQUENCY scale of Fig. 2. This reference frequency is the point on the curve at which the slope is downwards at 6 db/octave.

Explanation of the reason for choosing this reference frequency will help to clarify the information conveyed by the charts. An alternative presentation² uses the peak frequency as reference, where peaking occurs, and an imaginary equivalent where there is no peaking, the exception being the boundary case between the two regions, which has to be treated separately. This presentation has the advantage of providing precision prediction of any individual response more readily, because a "universal" curve representing each region can be drawn, which is interpreted by its own db conversion chart to suit all values within the region. Its disadvantage for the present purpose is that the reference frequency slides off the opposite end of the scale as the critical boundary condition is approached, i.e. it falls to zero

² *Electronic Engineering* (England) Nov. and Dec., 1951, and Jan. and Feb., 1952.

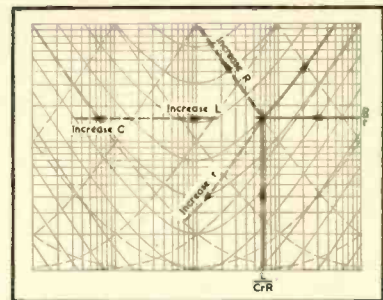

Fig. 4. Showing how the effect of changing circuit values is estimated by use of Fig. 1.

for h.f. cut-offs and rises to infinity for l.f. cut-offs; this makes presentation of varying response with different circuit values obscure, if this reference is used. The use of the 6 db/octave reference point enables continuous presentation through both regions.

The 6 db/octave slope point is also the frequency at which phase delay (or advance in l.f. cut-offs) is 90 deg. The phase characteristic is always symmetrical about this point, and the amplitude response may also be regarded as centered about this point, if it is referred to a 12 db/octave cut-off at this same frequency, instead of to zero level both sides of cut-off.

Notice that the curve in Fig. 2 with zero level at the reference frequency has a peak of about 1/4 db at a relative frequency of 0.7; the -3-db-at-reference-frequency curve is the critical or boundary case where peaking ceases; this is not quite the same as what is generally known as critical damping in connection with the introduction of transient distortion; critical damping, according to the accepted definition, is achieved by the -6-db-at-reference-frequency curve.

The scales used in Figs. 1 and 3 have been chosen to assist accuracy in drawing. The R/r scale on Fig. 1 is based on the law $\log(1+R/r)$, which allows a template to be used for the db rulings. By adjustment of the L/CrR scale, straight db rulings could have been used, but the conventional log scale makes reading of L/CrR values easier. In Fig. 3 the scale for R/r is based on $\log(1+$

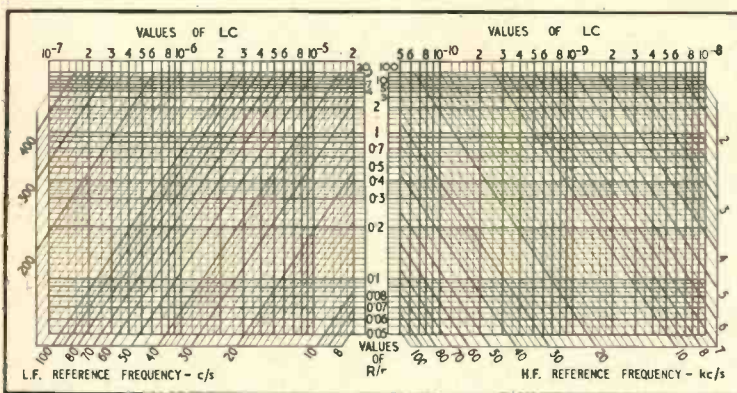

Fig. 3. Charts to determine the frequency location of the response predicted by Figs. 1 and 2. The left chart applies to l.f. cut-offs and the right chart to h.f. cut-offs.



At least one more octave of silky highs!

ADD THE T-35 *Super Sonax* VERY HIGH FREQUENCY DRIVER

THRILLING UPPER OCTAVES are silky smooth and completely reproduced with E-V's new Super Sonax very-high-frequency tweeter. Economically add it to your extended range single speaker for a 2-way system . . . to your coaxial for a 3-way . . . or to your separate multiple 2-way for a super 3-way system. It is easily installed in a few minutes. Takes over from 3500 cycles to limits of audibility. Famous E-V patented diffraction horn insures 180° dispersion. Readily mounts into your present enclosure or E-V folded horn corner enclosures.

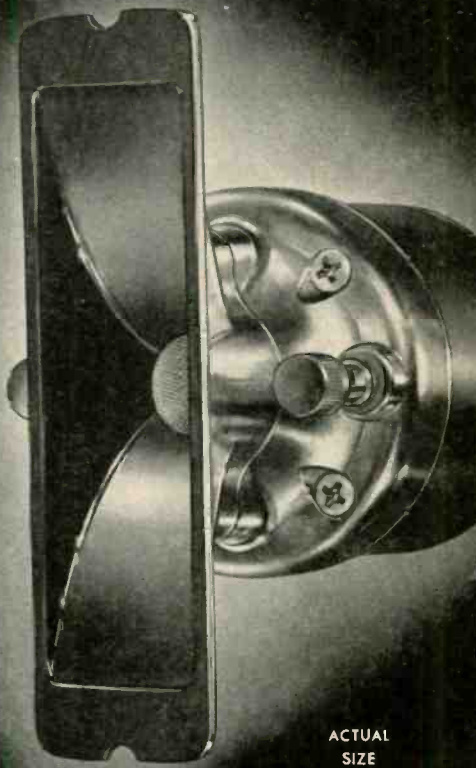

ACTUAL SIZE

T-35 SUPER SONAX	
	A Complete VHF Reproducer. Includes both the Driver Unit and unique Diffraction Horn. Can be added to any existing speaker system.
T-35 + X-35	FULL RANGE SPEAKER = ... 2-WAY SYSTEM
T-35 + X-36	COAXIAL = ... 3-WAY SYSTEM
T-35 + X-36	TWEETER + WOOFER = SUPER 3-WAY SYSTEM
	The new T-35 reproduces the brilliant highs, the treble overtones, the sparkling harmonics that typify the broadest sweep of orchestral fancy.

T-35 SUPER SONAX. For any system up to 40 watts. Response: 3500 cps to beyond the range of audibility. Polar Pattern: 180° dispersion. Impedance 16 ohms. Cut-off of Diffraction Horn 1500 cps. RTMA Rating: +56 db. Horn: 4½" long x 1¼" wide. Pot Diam: 2½". 3¼" deep over-all. Net Wt. 2 lbs. List Price, \$49.50 Audiophile Net, \$29.70

X-36-1 CROSSOVER. Recommended for use with T-35. Full M-Derived ½ section. 3 db lc35 point, 3500 cps. Impedance: 16 ohms in and out. Metal case: 3¼" w x 3½" d x 3¾" h. List Price, \$11.25 Audiophile Net, \$6.75

AT-37 LEVEL CONTROL. 16 ohm L Pad; for use with Model T-35. Adjusts output level to individual taste. List Price, \$5.00 Audiophile Net, \$3.00

See Your E-V Distributor
or Write for Bulletin.

Electro-Voice

409 CARROLL STREET • BUCHANAN, MICHIGAN
Export: 13 East 40th Street, New York 16, U. S. A. Cables: Arlab

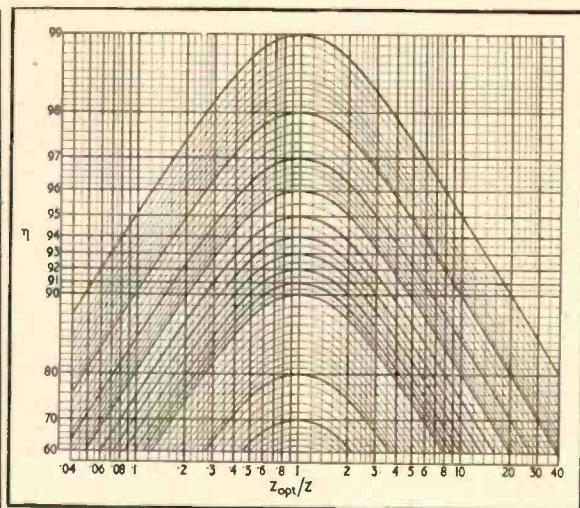
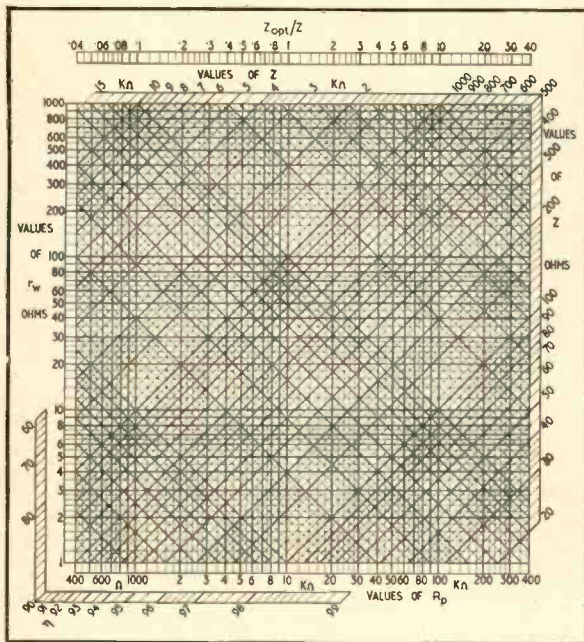

Fig. 5 (left). Chart to determine maximum efficiency, η , of a transformer, and the ratio of actual operating impedance to the impedance giving maximum efficiency. Fig. 6 (above). Chart applying the information from Fig. 5 to find the actual efficiency at the operating impedance.

r/R), allowing straight rulings to be used for frequency reference. Here the cramped spacing of the R/r scale toward the top gives an idea of the reduced effect on frequency when its value is large. The author has in preparation a book on the use of audio transformers, using charts with a different configuration again: a cut-out log scale can be applied to show the effect of variation in R , r , L , or C values more definitely; however, it was felt that this idea was not appropriate for a magazine article, so advantage is here taken of the construction yielding greater accuracy.

Adjustment of Values

Use of the 6 db/octave slope frequency as a reference does not mean that the frequency does not change at all as circuit values are altered, but that the change is easier to visualize or assess. If either $r=0$ or $R=\infty$ (the former never occurs and the latter seldom), variation of the other value would change the response in the way shown at Fig. 2 without changing the reference frequency. Values of R and r such that both contribute to the damping push the reference frequency upwards for h.f. circuits or downwards for l.f. circuits, to the degree indicated by the chart of Fig. 3. Variation of L or C will change the reference frequency in inverse proportion to the square root of their value, the chart of Fig. 3 again being used to calculate this.

Figure 4 shows how the chart of Fig. 1 may be used to visualize or estimate the effect of changing circuit values. The dotted lines on Fig. 1 represent a condition where L , C and either r or R are maintained constant, while the fourth quantity is varied. Figure 4 shows clearly the direction of movement along these dotted lines (or paral-

lel with them) for increasing values of r and R respectively—decreasing values naturally produces movement in the opposite directions. Increasing L , or decreasing C , moves the reference point horizontally to the right, and increasing C , or decreasing L , moves it to the left.

In h.f. circuits, L is set by leakage inductance, but C can be increased by the addition of shunt capacitance across the high-impedance winding. In l.f. circuits, L may be variable by adjustment of the gap, and definitely does vary with signal level; C , the coupling capacitor, can be made any desired value.

No provision is made on the chart of Fig. 1 for $R=\infty$. In cases where a step-up transformer may be working without a secondary loading resistor, a high value may be assumed. It will be noted that the dotted lines representing

variation of R , with other values constant, converge to become parallel with db rulings towards the top left hand corner of the chart. A high value of R will produce a reading in this area, where its precise value will not appreciably affect the db reading.

Efficiency

In transformer circuitry, insertion loss is more readily dealt with in terms of efficiency. Percentage efficiency can easily be converted to db insertion loss by log table, slide-rule, or one of the ready made conversion tables frequently published. Efficiency relates to power transfer—and not voltage transfer—so for example, an efficiency of 60 per cent is an insertion loss of 4 db, 90 per cent

[Continued on page 74]

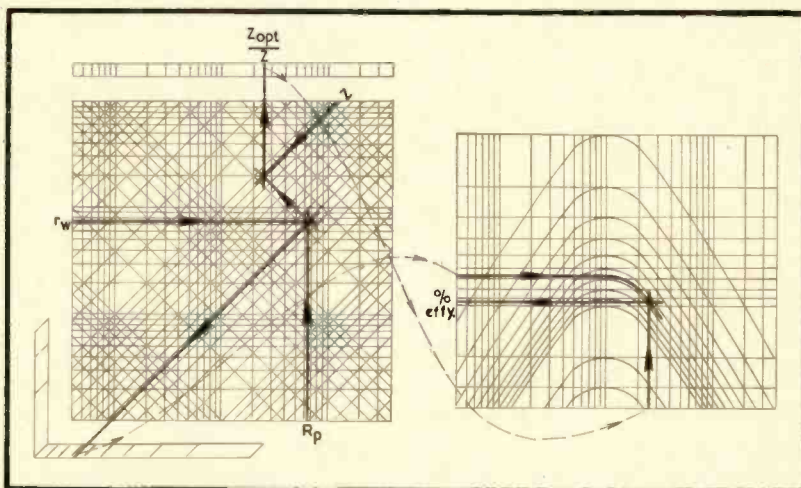

Fig. 7. Showing how the charts of Figs. 5 and 6 are used to find the efficiency of a transformer.

HARVEY the House of Audio



STROMBERG-CARLSON FM-AM RADIO TUNER Model SR-401

An unusually high quality tuner with separate FM and AM sections, using variable permeability on FM, variable capacitance on AM, and a sensitive bar-type tuning eye. Delivers 3 volts across a .25 megohm load with less than 1% total harmonic distortion. Has 5 microvolt sensitivity for 30 db. of quieting. Frequency response is 20 to 20,000 cps flat within 1 1/2 db. on the FM band. Four knobs furnish the following controls: VOLUME combined with Power Switch... FM and AM SELECTOR with choice of Band Pass or Narrow Band selectivity on AM... AFC "on/off" SWITCH... and TUNING FM and AM Station Selector. Dimensions: 11 1/4" long, 6 1/2" high, and 11" deep.



\$139⁹⁵



STROMBERG-CARLSON 10-WATT HI-FI AMPLIFIER Model AR-410

A high quality amplifier, ideal for medium power requirements such as found in home installations. Power output is 10 watts with less than 1% total harmonic distortion, and response is flat from 20 to 20,000 cps. within 1 db. Has a hum balancing control, and attains a hum level 70 db. below full rated output. Six input jacks for the following front ends: Low Level and High Level Magnetic Phono Cartridges... Low Level and High Level Radio Tuners... Low Level Microphone... and Auxiliary for TV, Tape Recorder, Crystal Pickup, etc. Four knobs provide front panel controls: SELECTOR SWITCH for Microphone, Foreign Records, American Records, Radio, and Auxiliary... LOUDNESS CONTROL which compensates for Fletcher-Munson curves... BASS CONTROL with 15 db. boost to 20 db. attenuation of 30 cycles... and TREBLE CONTROL with 12 db. boost to 20 db. attenuation at 10,000 cycles, plus power switch. Output impedances are: 4, 8, 16, 150, and 600 ohms. Built-in pre-amplifier/equalizer serves the record types covered by the selector switch. Dimensions: 11" wide, 7" high, and 8" deep.

Complete with tubes: 12AU7, 12AX7, 12AT7, 2-6F6, and 5Y3. \$79⁹⁵



R-J SPEAKER ENCLOSURES BOOKSHELF MODELS

The new famous R-J cabinet developed to new dimensions. Small enough to permit it to be inconspicuously mounted on a bookcase shelf. Reproduces amazingly clean, smooth, bass fundamentals while permitting direct radiation of high frequencies. An ideal system

where space is at a premium or as an extension reproducer in an extra room. May be finished to match the decor.

- Model S-8-U for 8 inch speakers (11" high x 10" deep x 23 1/2" long) \$24.50
- Model S-12-U for 8 inch speakers (24" high x 10" deep x 21" long) 29.50

WESTERN ELECTRIC 755-A SPEAKER (8" PM)

A remarkable value, ideal for use with the R-J Model S-8-U. Provides full frequency range coverage and wide angle high-frequency distribution. SPECIAL \$24⁶⁰

HARVEY is the HOUSE of AUDIO

Whatever it is in the field of Audio, you can be sure to find it at Harvey... in stock, and ready for immediate delivery wherever you may be. Your inquiries are invited. NOTE: Prices Net, F.O.B., N.Y.C. Subject to change without notice.



The NEW MINIFON Miniature, Portable WIRE RECORDER



Measuring only 1 1/2 x 4 3/4 x 6 1/2, and weighing only 2 lbs. 7 ozs., the Minifon is just about the world's smallest sound recording instrument. Records, rewinds, erases, and plays back through either a pair of stethoscope type earphones or an external amplifier. Capacity 2 1/2 hours uninterrupted recording. Powered by 1 1/2 v. A battery, standard 30 v. B battery, and 7 Mallory RM-4Z mercury batteries. An ideal tool for executives, engineers, doctors, and wherever there is need for recording notes, interviews, and other data.

Complete with microphone, stethoscope type earphones, 1 hour spool of wire, tubes, batteries, and instructions. \$250

Morocco Leather Zipper Case \$7.50
Transformer-rectifier Unit for operation of motor from 117 v. AC line \$20.00

RECORDING WIRE On spools, in dust-proof plastic containers, suitable for mailing.

1/4 hour	\$5.00	1 hour	\$9.00
1/2 hour	7.00	2 hour	17.90
	2 1/2 hour		21.50

The ORIGINAL WILLIAMSON HR-15 Amplifier Kit

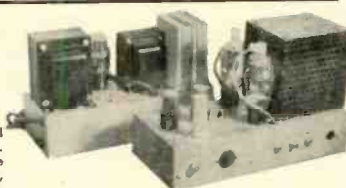

The famous, original Williamson HR-15... still acclaimed the leader... In kit form, with the Partridge Output Transformer specified by Williamson in his original design. Assemble this kit, and in 3 hours or less, enjoy the finest sound you ever heard. Operates from a tuner, phono-preamp, crystal pick-up, or other signal source. Absolute gain is 70.8 db with 20 db of feedback. Frequency response: -5 db, from 10 to 100,000 cps. Output impedances to match all speakers from 1.7 to 109 ohms. Kit is complete with 5 tubes: 1-5V4, 2-6SN7, and 2-5881 (or 807 if requested), 2-Punched Chassis, 2-Resistor Mounting Strips, Sockets, Partridge WWFB Output Transformer, Assembly Instructions, and All Other Necessary Parts for Amplifier and Power Supply \$76.50

PARTRIDGE OUTPUT TRANSFORMER WWFB - Available Separately \$26.50

HR-15T Williamson Kit - Furnished as above, with TRIAD Transformers and Chokes \$69.50

NOTE: HR-15 and HR-15T Kits may be had with British KT-66 Output tubes for \$3.00 additional.



CARTER SUPER CONVERTERS

Deliver clean 60 cycle AC power at 115 volts. Operate from storage batteries or other DC source, and available for 6, 12, 24, 28, 32, 64, or 115v input voltages. Ideal for an-notation recordings with quality equipment. Write for complete data and prices.

CANNON PLUGS and CONNECTORS

The standard of quality for over 15 years. You'll find them wherever the ultimate is required in low level sound transmission, and general electrical and electronic applications. Write for complete data and prices.

COMPLETE STOCKS CARRIED AT ALL TIMES FOR IMMEDIATE DELIVERY



HARVEY RADIO COMPANY, INC.

103 W. 43rd Street, New York 36, N. Y. • LUXemburg 2-1500

RECORD REVUE

EDWARD TATNALL CANBY*

SUSPENDED IN SPACE

WHAT ABOUT all this excitement over "binaural" recording, broadcasting, reproduction? It was only a year or so plus some, that we first heard of commercially available two-channel recording, via Magnecord. At that time the "binaural" Magnecorder was no musical instrument. On the first announcement, down in a small paragraph headed HOME, there was a brief mention of the enhancement of music by twin-channel recording; but the rest of the blurb was all about industrial uses, business conference work and the like. A lot seems to have happened since then!

"Binaural"—the quotes used advisedly—was the sensation of the recent Audio Fair and the pronouncements concerning its wonders were so joyous and jubilant that many went forth astounded. A few, I regret to say, went away convinced that the whole thing was publicity. It was surely that! The demonstrations were impressively staged and expensive, indeed a bit overpowering in their splendor. Wherever one went, there was "binaural," in an assortment of forms from earphones to batteries of trumpet speakers. Steam engines as big as a house snorted in and out deafeningly, shaking the rafters, ping-pong games were played twenty times life-size, musical comedies, symphonies, great organs peeled forth both loud and soft (but mostly loud), persuasive gentlemen announced, "binaurally," that they would now walk to the right . . . and then to the left . . . and few of the enthralled listeners were disturbed when for some reason they seemed merely to tromp up and down on the same spot, vaguely located near the ceiling. Soloists performed grandly out of the Right Speaker and the Left Speaker and only a handful were heard protesting that there were two of each, like double vision. "Binaural" music for you and me was everywhere proclaimed, but somehow the details were left a bit indefinite.

Quarter-Baked

Don't be misled—in the wrong direction—by all this "binaural" excitement, in case you have already discounted two-channel recording as one more publicity stunt. Maybe it won't be *that* good (nor that

soon). But there is definitely something in it, behind the big-gun stuff now going on. The trouble with "binaural" music right now is that it is scarcely begun to be developed for practical use. A fine big chocolate cake, but somebody took it out of the oven quarter-baked. And the "binaural" programs at the Fair and via broadcast, in spite of some very excellent results, were in the large just that. Confusions, contradictions, false and faulty effects, happily swallowed up in the general excitement. Perhaps this is as it should be. We Americans usually launch our new projects in this high, wide, and handsome way. But somebody has got to untangle things sooner or later or the fine little "binaural" boomlet will collapse . . . well, like a quarter-baked chocolate cake.

This department did some speculating on this question a year ago (*Æ*, Dec. 1951), nor was that the first time "binaural" had been injected here, an earlier and very long-winded piece of mine (*Æ*, Jan. 1950) having had to do with the strange relations between binaural and monaural liveness, for recording and broadcast. Not a simple area at all, but the present "binaural" experiments have got us far more confused than ever before. I'll make only one major, fundamental point here, to illustrate the sort of straightening out that must be done before we know where we're going in this. Do we really mean binaural?

Binaural—Without Quotes

All recording and broadcasting is now done via one channel, with from one to *n* mikes and the same at the speaker end. Monaural *Illusions* of reality can be accomplished extraordinarily well, given good microphoning and good listening acoustics in the reproduction. Nothing new about that. True binaural reproduction must, however, duplicate the two sounds heard by two ears—and, ideally, reproduce the effect of the original two eared listening. True binaural, effecting complete separation for each ear, is done only with earphones. The dual microphones are placed as nearly as possible to simulate a head with ears. No loudspeaker combination can possibly give a true binaural reproduction, since not only will the two channels overlap, both ears hearing both speakers, but there is a false

sense of direction injected by the fact that the speakers themselves are directionally spotted—thanks to our hearing each of them with *both* ears. But do we need true, literal binaural? That is an interesting question.

Simple Substitution

There is an entirely different plan of action called stereophonic sound. This plan is simple. Forget about two ears, one channel for each. Instead, use two, or three, or numberless channels to put the sound sources spatially in the place where they ought to come from, right to the right and left to the left. With but two channels you can record a piano on one side of a stage and a singer on the other, each with his mike; then put speakers in place of the mikes, remove the performers and play the recording. You'll have them in their proper spots—because they *are* in their proper spots, by recorded proxy. Substitution. You can move the speakers about as if they were the performers themselves and have them "perform" in any old position you want. Nothing whatsoever to do with two-eared, binaural transmission.

For more than two performers, for a whole area of sound, more mike-record-speaker simultaneous channels are needed—theoretically an infinite number. But, as was shown 'way back in 1934 by Stokowski *et al*, three channels—one to each side and one for the middle—will give an excellent and close approximation of full substitution coverage. You'll find a similar system in use now for the fabled "Cinerama". It is *not* binaural. No earphones! (Nor is "Cinerama's" picture a stereo picture—one picture for each eye. Its several pictures are spread out exactly as is the sound, the simultaneous projections overlapping at the edges as do the sounds from the simultaneous recording channels.)

20 Feet

Now, my chillun', for the \$64 question. Just which of these systems are we trying to use, in our so-called "binaural" recording?

It should be apparent to you that we have been dabbling heavily in both, mixed together. We have had something of every-

* 780 Greenwich St., New York 14, N. Y.

In music,
listening
quality
is everything

"My wife and I drove some 400 miles to New York, just to witness that concert of yours at the Audio Fair. For over an hour we waited in line, but it was worth it. No amount of advertising could have made me believe such a thing possible. Closing our eyes, we could not tell which was playing—the live artists or the AUDAX CHROMATIC. Thank you for this thrilling experience. It will stay a memorable event in my musical life. I am going to" (from a letter)

The revolutionary new records are so true to the original that almost any pick-up is bound to give some results . . . but—it takes a reproducer of the highest order, one sensitized to the nth degree . . . a CHROMATIC POLYPHASE—to bring out every subtle shading, every nuance so essential to the real music of which these discs are capable. . . . Therefore . . . SEE and HEAR CHROMATIC and —YOU be the judge.

- Audax costs no more than ordinary pickups
- One single magnetic pickup plays all home records
- Only AUDAX has individually replaceable Sapphire or Diamond styli.
- Response 10 to over 15,000 cps.
- Needle-talk practically nil*
- Near-infinite compliance
- Phenomenal tracking

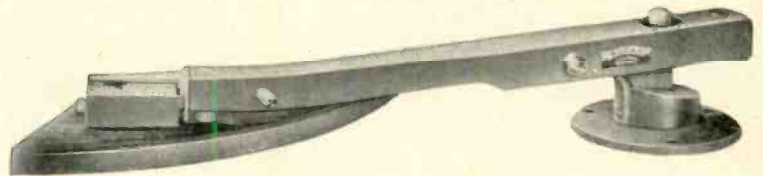

Available with the new compass-pivoted Audax arms and to fit record changers. Audax arms are the simplest and most efficient yet devised

***Be sure to obtain a copy of 1953 ELECTRONIC PHONO FACTS from your distributor.**

AUDAX COMPANY
500 Fifth Avenue New York 36

Creators of Fine Audio-Electronic apparatus for over 25 years.

"The Standard by Which Others Are Judged and Valued"

CANNON PLUG ACCESSORIES

for the "AN" Series



RIGID CONDUIT FERRULE
AN3053



CONDUIT COUPLING NUT
AN3054



ADAPTER
AN3055



CONDUIT COUPLING
AN3056



CABLE CLAMP AN3057



CABLE CLAMP AN3057A



CONDUIT COUPLING
AN3058



90° CONDUIT COUPLING
AN3062



90° CONDUIT COUPLING
AN3063



BOX CONNECTOR
AN3064

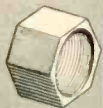

CONDUIT COUPLING LOCKNUT
AN3066



STRAIGHT JUNCTION SHELL
NO. 2179

CONDUIT COUPLING ADAPTER
AN3069



ANGLE 90° JUNCTION SHELL NO. 2245



DUMMY RECEPTACLE
NO. 2182



DUST CAP NO. 2709



BONDING RING
AN3111

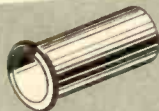

TELESCOPING GLAND BUSHING
AN3420

Here is the answer to a frequent question we receive from people everywhere. Yes, Cannon *does* make a complete line of accessories to be used in conjunction with the AN Series of connectors. Complete engineering data on each of these is given in the Cannon AN Bulletin, available on request.

CANNON ELECTRIC

Since 1915



Factories in Los Angeles, Toronto, New Haven, Benton Harbor. Representatives in principal cities. Address inquiries to Cannon Electric Company, Dept. A-109, P. O. Box 75, Lincoln Heights Station, Los Angeles 31, California.

We have had mikes at 20 or more feet separation—fed into earphones, as though for a binaural effect. Do we intend, thus, to make a "giant" head for ourselves, putting our two ears thus far apart? We do just that, if we play the result through earphones, filling each ear totally with the sound from one mike alone. The two sounds can then only be fused inside the head. The earphones obviously are not located at the place where the sounds are supposed to come from; we'll have to do the locating mentally, via interaction of the two ears. That's binaural, pure and simple. No substitution.

But play the same recording, with 20 foot mike spacing, into two speakers 20 feet apart, and you have something else again. Very different. The speakers are actually in the positions of the original sound, more or less. They act as substitutes, proxies on the spot—and this is the substitution system again. Stereophonic.

We've also had much two-channel recording (or broadcast) with mikes close together, as on a head more or less. Say between 6 and 20 inches. A slightly swelled head, but a head, nearly enough. What happens when such a recording is played through loudspeakers spaced apart—say 20 feet? Interesting. The close-to mikes can give no substitution effect, on the spot. Too close. Whatever effect there is must be binaural—the interacting of the two sounds inside your head, to produce a *seeming* direction—if there is any direction-effect.

\$10,000 question

Is it possible, then, to get a *binaural* effect in any degree with two speakers—i.e. an effect that is independent of the actual position of the two speakers themselves, as you look at them? To put it concretely, can you record a single person's voice, say, two-channel via two closely spaced mikes, then play him back through two speakers widely spaced—say 20 feet apart—and *have just one of him appear, midway in space between the two speakers?* This, rather than two of him, one coming from each speaker. That, my friends, is the \$10,000 question. Direction is only one aspect of binaural realism, to be sure. There's lots more to it. But if you can achieve that, you'll have the rest in the same measure. And music in the home will be impressively benefited.

Let's pause here, for a good breather. I'll say only that once—just once, so far—I have had definite proof that this is possible. I heard my own voice suspended in space between two speakers. Just one of me. I'm going to do my best to find out how I did it!

RECORDS

Opry and Drama

(There are such floods of standard repertory opera now appearing on LP that this department takes a big breath and swims dizzily towards the quieter reaches—here—with a few unusual works of great interest.)

Mozart, Zaide. Paris Philharmonic; Mat-tiwilda Dobbs, Hughes Cuénod, Bernard Demigny, etc., Leibowitz.

Polymusic PR 901/2

Old Mozart fans will gulp at this—for it is only half an opera, unfinished, and was never performed; few music lovers even know of its existence. Not a minor opera, either—this would have been one of the major works; but for reasons probably commercial, Mozart casually dropped it in the midst and went on to another which was commissioned and would, he knew, be

performed. Zaide was, however, re-done in the later work, *Die Entführung*, one of the gayest, silliest, most brilliant pieces of Turkish slapstick you can imagine. (London has it on fir.) This one was to have a similar Turkish harem sort of plot. Only the arias for two acts and some wonderful "Melodram"—spoken text with musical accompaniment and interludes in a style suggesting today's radio technique—were completed.

A good performance, in spite of the polyglot cast, a French orchestra and conductor, a Swiss hero (Cuénod) and so on; the playing is a bit rough and a trace hard, but the essential Mozart gets over beautifully, especially through the superb singing of the leading lady named Dobbs. If you enjoy this sort of Mozart, here is a wealth of new material of the first rank.

Purcell, Dido and Aeneas. Flagstad, Schwarzkopf, Mermaid Theatre Company, Jones.
HMV LHMV 1007

The first, and perhaps greatest English opera, here at last complete and done in the original shape without fancy "arranging"—but the feature of this HMV LP is Flagstad, who has never sung more beautifully, nor been recorded more gracefully. If you don't know Henry Purcell, the first time through may leave you with a feeling of strangeness—but in no time the wry, penetrating strength of this composer will get you, the silly text ("Our plot has took, the Queen's forsook!") will reveal the tragic emotions beneath it. Elizabeth Schwarzkopf is also superb—both ladies sing and speak perfect English, in the purest English manner; the direction is rhythmic and lively; the orchestra, harpsichord, and chorus all tops. Recording is unusually fine, with but one drawback: the LP sides are too long, with considerable distortion in the inner grooves, as heard wide-range.

Mozart, Così fan tutte. Steber, Thebom, Peters, Tucker, Metropolitan Opera Orch. and Chorus, Fritz Stiedry.
Columbia SL 122 (3)

You'll have to buy three LP's here, to experience some of the finest technical opera recording yet done. Whatever the method (and artificially added liveness is a good bet), the effect of depth, perspective, "width" in this sound is no less than fabulous. Shows what extraordinary illusions can be created in the monaural medium, given the right mike setting. The orchestra seems huge, yet is not, and each instrument is ultra-clear, the drums full and sharp, the strings close and stringy (close-up mikes?). The voices are recorded quite close, a convention which, if quite unfaithful to the original opera-house sound (the voices at stage distance), is clearly the best way to get opera over on records.

The opera itself? First Mozart to be done complete here, it is in English—the frothy, silly but ultra-clever little farce translated into language that—thank Heaven—not only makes reasonable sense but, more important, is beautifully fitted to the music. Sounds natural—which is a feat in opera-in-English! Very complete notes and comment are a tremendous help in the listening. This is the way to hear opera! When you know it cold, on records—then go to the opera house and see it in the flesh, with enormous appreciation. Lively performance under Stiedry, the slighty Americanized atmosphere following naturally from the American text. You can understand every word.

Offenbach, La Belle Hélène. Linda Felder, André Dran, Paris Philharmonic Orch. and Chorus, Leibowitz.

Renaissance SX 206 (2)

Know French? If you understand three words of it, this opera—operetta, I should say—will knock you over with a feather, to mix metaphors. This is the ultra-French version of Gilbert and Sullivan, mixed up with a considerable dash of what might be U. S. musical comedy. Preposterous plot involving the great Greeks—who turn out to be side-splitting imbeciles, canny plotters, the story making about as much sense as G & S, moving at least ten times as fast in the most incredibly clear and lightning-speed French, both spoken and sung. It takes the French to put on a whirlwind show like this, screamingly funny, yet with a technique that is breath-taking in its virtuosity. You'll recognize a lot of the music and,

ADD A
DUPLEX
FOR
QUALITY



• Few radio, phonograph console loudspeakers have a frequency range as great as the radio or phonograph itself. To realize the full quality range of your console, replace the present loudspeaker with an Altec "duplex." You can do it yourself in minutes . . . without special tools or engineering knowledge. And you will hear every tone your radio is capable of producing . . . for the Altec "duplex" has a range far exceeding that of the finest console on the market. Add a "duplex" and you can have high quality sound in your home today.

See and hear the complete Altec "home music system" at your nearest high fidelity studio.



Write for the
"duplex" brochure.

9356 Santa Monica Blvd., Beverly Hills, California • 161 Sixth Avenue, New York 13, New York

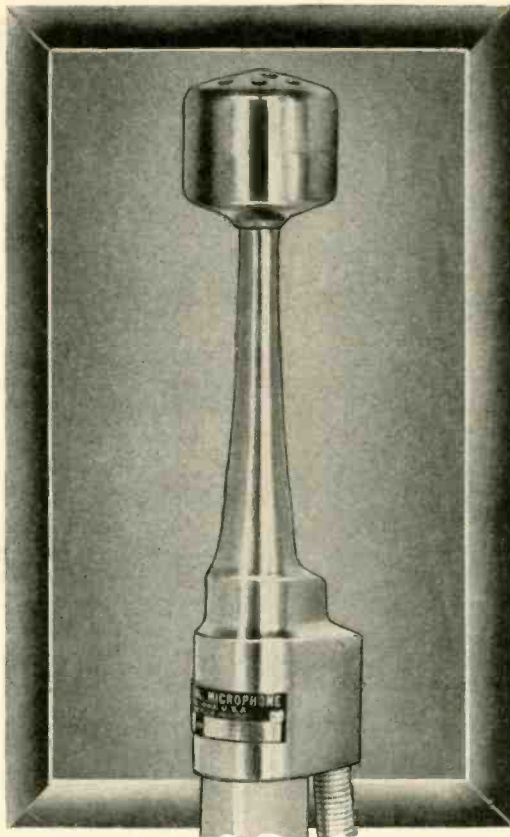

portrait of a great new microphone . . .

THE TURNER 80

Why the 80 is best for you . . .

Reports are pouring in from all over the country.

- 1 "Greatest little mike on the market . . . it's a beauty!"
- 2 "It's tops for sound performance and versatility."
- 3 "Congratulations on maintaining your high quality."

These are typical of the comments from purchasers of the new Turner Model 80 crystal microphone. The Turner 80 has proved itself in hundreds of applications—and has become immediately popular for public address work as a result of its small size and excellent performance. Pictured actual size here, the Model 80 is so tiny it hides in the palm of your hand—weighs only 5 ounces. It's a natural for PA, home recorders, dictating machines and amateurs. Finished in satin chrome. 7 foot attached single conductor shielded cable included. Level: 58 db below 1 volt/dyne/sq. cm. Response: 80-7000 c.p.s. List Price _____ \$15.95

THE TURNER COMPANY

929 17th St., N. E. Cedar Rapids, Iowa

CANADA: Canadian Marconi Co., Toronto, Ont., & Branches

EXPORT: Ad. Auriemo, Inc., 89 Brood St., New York 4



Crystals licensed under patents of Brush Development Co.

with the complete printed text, will be delighted at the book. Just repeat "L'homme a la pomme" at a speed of 100 times a minute and you'll get the feel of the show. That's one of the choruses. Terrific.

NOVELTIES

Mozart, Piano music (Sonata, K. 533; Rondo, K. 494; Adagio, K. 540; Fantasy and Fugue in C, K. 394; Rondo, K. 485.) Paul Badura-Skoda.

A. On a modern piano.

Westminster WL 5154

B. On a piano of 1785.

Westminster WL 5153

Mozart, Piano Sonata in B flat, K. 570; Suite, K. 399; Fantasy and Fugue in C, K. 394. Ralph Kirkpatrick, Challis 18th century type piano. Bartok BRS 912

Here is a challenging musical and intellectual experience for the curious minded. Mozart wrote, in the late 1700's, when the piano was scarcely begun on its modern development—yet he obviously found it good for his purposes, as did his listeners. Is Mozart improved when played on our perfected modern piano? Is the piano itself better now?

Tricky questions. Technically the modern piano is of course "improved." Louder, smoother, more sure in its action, bigger, and so on. But mechanical improvements often change the character of an instrument. A skilled composer writes for his instrument, as is, and takes advantage of its qualities, even the "bad" ones, for positive musical ends. The plain fact is, as these records will persuade you, that Mozart sounds extremely well on a Mozart-period piano—perhaps a good deal better than on the modern instrument. The peculiar soft, twangy tone qualities that, for later music, might seem ugly, are for this music rather perfectly suitable. The effect, paradoxically, is richer, more emotional than on the big new piano—perhaps you will now discover why Mozart so often sounds thin and unimportant on our instrument.

Badura-Skoda, a young player who is one of the finest Mozart pianists we have, gives us a splendid working comparison on the two pianos, my only reservation being technical: from what I know of the instrument, I suggest that the old piano's bass is somewhat unnaturally heavy and big here. This is a rebuilt Viennese piano dating from Mozart's day. Ralph Kirkpatrick, harpsichordist and authority on the older music, gives a good performance too, of a drier, less fluent sort (influenced, I'd say, by the harpsichord style of playing). His piano is a newly built one, a compromise reconstruction taken from a number of different piano types of around 1800 "averaged" together. The Bartok recording is superb, giving a better idea of the instrument than the Westminster.

What are we coming to—when, after a century of constant technical improvement, we now go back and deliberately build a Mozart piano, reversing the entire piano development! Same thing for the so-called "Baroque" organ, now so popular; it is no more than a revival of 17th and 18th century organ mechanisms, on which to play the music of that time, for better effect. Makes one think a bit.

Schubert, Symphony #7 in E major, arr. Weingartner. Vienna State Opera Orch., Litschauer. Vanguard VRS 427

It is not often—or it was not often—that a major work of a supremely great composer appears on the scene for the first time. Here, for most of us, is such a work. The 7th symphony was left by Schubert in sketch form, "complete," but in a sort of shorthand. (How many of us leave unfinished projects about in this fashion, waiting for the convenient time to do a bit more hard work. . .) It was not heard until Weingartner, the conductor, made a playable version of it in 1934 for orchestra—here recorded.

This symphony (and we hear substantially what Schubert intended) comes between the early six, of which several are now very popular, and the Unfinished, of endless fame. Between that and the "Great C Major", almost as popular, came that other mystery-work, the "Gastein" symphony, which disappeared without a trace but is presumed to be the same music as the Grand Duo for two pianos opus 140. It was recently re-

corded, on this assumption, in an orchestral arrangement approximating what Schubert intended. (Vanguard VRS 417). What a human and fallible man this Schubert was—his musical affairs in a constant state of semi-confusion, his fantastic musical ability pouring out new music faster than he could organize it into properly finished products!

Both the "Gastein" and this E Major work are thoroughly big pieces; both are full of the things we know better in the familiar Schubert. If you have been captivated by the Great C Major (wrongly called #7 or #9, though it is actually #10)—or by any of the fabulous Schubert works for smaller instrumental combinations—you'll not go wrong on this one. Sympathetically, rather mellowly played by the Viennese orchestra.

Bird Songs of Dooryard, Field and Forest.
Recorded by Jerry and Norma Stillwell.
12" LP (Ficker Recording Svce., Old Greenwich, Conn.)

The first LP bird record (though Folkways Records has a South American Rain Forest recording of mingled sounds), this one follows roughly the pattern of the famous Cornell recordings issued in 78 r.p.m. form—spoken comment introducing the birds, pointing out features of the songs, etc. The recording quality of most of these is not as good as that in the Cornell records; there is much buzzing distortion, neither the highs nor the "lows" are as clear, and the birds seem often unnaturally close. (Both recordings use the parabolic mike extensively.) But the Stillwells have done good things, in comparing a series of different individuals of one species, in playing some songs half-speed, "slow motion," in the wealth of specific material on how to distinguish one bird from another. The long-play medium allows for greater leisure, longer excerpts. An important documentary disc as well as a most enjoyable production.

Anna Russell Sings? (Advice on Song Selections for Concert Singers.)

Columbia ML 4594

This dizzy dame, recorded at a "recital", is a take-off genius, making delightful and very musical fun of any number of styles and manners and schools of singing. The more you know of music the more pointed her satire—but the stuff is wonderful (in smallish doses) for anybody at all. Fine sense of presence, audience participation, belly laughs—on the record—until your own sides ache. Her English accent is lavhly!

PROTECTION

(from page 36)

will be of sufficient value to merit a reasonable charge therefor."

No response was made to this letter but later, when the suggested idea was put into operation, the Indiana court said, holding the originator entitled to recover,

"While we recognize that an abstract idea as such may not be the subject of a property right yet when it takes upon itself the concrete form which we find in the instant case, it is our opinion that it becomes a property right subject to sale.

"Of course, it must be something novel and new; in other words, one cannot claim any right in the multiplication table."

REFERENCES

- Millar v. Taylor, 98 Eng. Reprint 201, 234
Pidot v. Zenith Radio Corp., 31 N.E. 2d 385, Illinois
Bristol v. Equitable Life Assur. Soc., 30 N.E. 506
Haskins v. Ryan, 64 Atl. 436; 78 Atl. 566, New Jersey
Lueddecke v. Chevrolet Motor Co., 70 Fed. 2d 345
Masline v. N. Y., N. H. & H. R. Co., 112 Atl. 639, Connecticut
Liggett & Myers Tobacco Co. v. Meyer, 194 N.E. 206, Indiana



Model AI-900



RECORD COMPENSATOR

EFFECTS FLAT RESPONSE



General Electric engineered to bring you as close to the beauty of the original orchestration as possible when used with standard type G-E variable reluctance cartridges.

ADJUSTABLE PLAYBACK



Five selective settings which include two scratch filter positions for noisy records.

NEW RECORD LIFE



Noticeable high frequency distortion and background noise on old 78 records is greatly reduced. Your favorite collector's items take on a new, magic quality that rivals the original.

EASILY MOUNTED



Compact design permits mounting in any position. Easily connected between the pickup cartridge and the pre-amplifier input.



SEND FOR THIS NEW BULLETIN...

General Electric Company, Section 4413
Electronics Park, Syracuse, New York

Please send me the G-E Record Compensator Bulletin with Playback Curves.

NAME

ADDRESS

CITY STATE



GENERAL  ELECTRIC

the people who know
come to **LAFAYETTE**

Discriminating audiophiles have made Lafayette their headquarters for the world's finest high fidelity reproduction equipment. Lafayette, famous for over 30 years, invites you to stop in and talk over your requirements, or write for further information on Lafayette's components for your custom installation.

CUSTOM COMPONENTS IN STOCK!

PILOT

PILOTUNER AM-FM TUNER AF-821

Covers AM (535-1720 mc) and FM (87.5-108.5 mc.) Sensitivity 10 microvolts for 3 volts audio output with quieting on FM and 10 microvolts for 3 volts audio output on A.M. Automatic-frequency control circuit can be switched in or out from front panel as needed on FM. Built-in two stage pre-amplifier for high fidelity phono cartridges can be switched out for crystal phono cartridges. Separate input jacks for phonograph and TV. With tone controls in "Flat" position audio frequency response 20 to 20,000 cps ± 2 db. IF response on FM 200 KC, 9KC on AM. Audio output impedance 7,000 ohms. Panel controls: power on-off, volume, treble, selector, bass, tuning, AFC on-off. 8 tubes plus rectifier. Completely ready to install with all hardware. Size: 14 1/4" x 7 1/4" x 8 1/2" behind panel. **\$99.95**
Ship. Wt. 12 lbs.



PILOTONE HI-FI amplifier AA-901 **\$99.50**

PILOTONE Pre-amplifier PA-911 **\$29.95**

BOGEN

R701 AM-FM TUNER

Three range tuning, a dual limiter in the FM discriminator and a push button controlled AFC circuit provide maximum ease of tuning and an absence of drift. The AM circuit includes a variable band-width IF channel to permit selection of wide range response or maximum selectivity. A low impedance loop antenna is furnished. The R701 has built-in preamplifier to accommodate all popular crystal and magnetic phono cartridges, separate bass and treble tone controls, tuning and volume controls and input selector switch. Beautifully styled acutcheon permits easiest possible custom high fidelity installations. Sizes: 15" x 8 1/2" x 9". Ship. Wt. 17 lbs. **\$145.20**

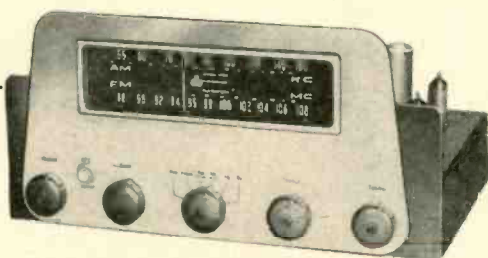

PHio-1 Amplifier now incorporates complete function selector switch **\$33.35**

"Baton" Remote Control Amplifier System with RXPX **\$149.95**

Lafayette
RADIO

HIGH FIDELITY HEADQUARTERS
100 SIXTH AVE., NEW YORK 13, N. Y.
BOSTON: 110 FEDERAL ST.
BRONX: 542 E. FORDHAM RD.
NEWARK: 24 CENTRAL AVE.
PLAINFIELD: 139 W. 2nd ST.

LAFAYETTE

FREE! HIGH FIDELITY CATALOG
Complete information on the world's finest tuners, amplifiers, speakers, etc. Mail coupon today!

Lafayette Dept. WA
100 Sixth Ave.
New York 13, N. Y.

Please send FREE Hi-Fi Catalog.

NAME
ADDRESS
CITY STATE

PATENTS

(from page 6)

curve 2; too low, like curve 3. Though the patentee does not say so, it seems that a safe setting to take care of tape variations would be a bit high but not so high that dynamic range is limited by nonuse of too much of the straight portion of the B-H curve of Fig. 1. Connell claims that his system gives high-quality results, without any of the usual bias-caused deterioration of the high frequencies.

Wide-range Probe

Today audio amplifier circuits have reached such a state of perfection that often the usual measuring instruments are not good enough to cope with them. For gain measurements or oscilloscope observation in early stages at high impedance, for example, the measuring instrument leads or probe must have negligible resistance and capacitance, which is far from true for most.

Edward W. Yetter has designed an instrument input stage which is simple and small enough to be built into a probe of reasonable size but has extraordinarily good characteristics. The patent covering it is No. 2,601,485, and it is assigned to Sun Oil Co. The probe has an input capacitance ranging around .01 μ f, input resistance of 1,000 megohms or so. It is linear for all input voltages from zero to around 100 volts and up to 1 megacycle. Its output is at low (cathode) impedance and can be fed to any sort of measuring equipment at all.

The circuit is diagrammed in Fig. 6. there are two tubes, a 954 acorn-type pentode and a 12AU7 miniature duo-triode. Probably the only component which need be mounted in the probe is the 954, with a short probe wire soldered or clipped to the grid pin.

The 954 is operated as a cathode follower. While the permissible range of input voltage of a cathode follower is greater than with plate output, it is still not particularly high when linearity is to be maintained. This is because of variations of potential difference between cathode and screen. The purpose of the 12AU7 is to maintain the screen-cathode voltage substantially constant so that the voltage range of the probe will be very wide.

Output is taken from the junction of R_1 and R_2 for the instrument being used. The value of R_2 plus R_1 is adjusted for linear operation of the first 12AU7 triode. Its grid is excited from the tap on potentiometer R_3 . With the two cathodes of the 12AU7 tied together, the second section is operated almost as a grounded-grid amplifier and the combination is simply a phase inverter. The cathode-plate path of the second triode acts as the grounded leg of a voltage divider, the upper half of which is R_4-R_5 ; screen voltage from the pentode is taken from this divider.

When the probe voltage goes positive, plate current in the 954 increases. As is usual in cathode followers, the cathode also goes positive, and some of the positive voltage is coupled to the grid of the first triode.

The first triode is also a cathode follower and its own cathode goes positive, as does that of the second triode, which is directly tied to it. The positive triode cathode voltage appears across R_6-R_7 to ground, which means that the grid of the second triode is somewhat negative with respect to its cathode. For that reason, plate current in the second triode falls; the tube is effectively a higher resistance and its plate goes

positive. The positive-going voltage at the plate of the second triode is the screen voltage for the 954. Thus, while the probe signal caused the 954 screen to go negative because of increased current flow, the second triode compensates for this by bringing it positive again. The amplification added by the triode to the compensating signal actually produces a positiveness which is more than proportional to the original change in 954 screen voltage. In this way, instead of going negative with increasingly positive 954 grid and cathode voltage, the 954 screen actually goes more positive than before to keep in step with its own cathode voltage. This maintains a fairly constant screen-cathode potential, preventing distortion for probe signals as high as 100 volts.

The four potentiometers need be adjusted only once, then locked. The idea is to adjust them for linear operation at the highest possible input voltage.

The additional features of wideband operation and low input capacitance are, of course, inherent in cathode followers, but they are bettered by the screen compensation as well.

A copy of any U. S. patent may be had on request from The Commissioner of Patents, Washington, D. C., for 25¢.

LOUDSPEAKER

(from page 34)

brought together you have great music.

Now it is conceivably possible that all this complicated ritual might be scientifically analyzable, but I do not think it has ever been done. The result is determined by long empirical experiment both in making the instrument and in playing it, and the excellence of the result is determined by aural testing in the presence of musical experts. The Amati family, for example, found by repeated trials that a certain type of wood, cut and shaped in a certain way, assembled in a particular manner and varnished with a lacquer of a certain composition, produced violins that were esteemed by musicians, and they had not the foggiest notion of the mathematical principles underlying their work, nor—may we hazard a guess?—has anyone else. Their instruments had a certain "tone color" which was greatly admired by violinists and musically conscious listeners, and how they got that tone color was their family secret, found out by empirical experiment.

When one comes to consider the design of a loudspeaker a similar state of affairs exists, but the aim is different. A speaker is not a musical instrument, it is a reproducer of musical instruments, and therefore it must have no tone color at all, otherwise its reproduction of the original music will be false. There is no way of scientifically determining beforehand how to achieve this desirable property, and when the design has been completed there is no way of finding out if the design is successful except by listening to it. And that is where the trouble starts. That is why so many musicians do not like that type of reproduction commonly called "high-fidelity." They seem to prefer the sort of distortion that one gets with "middle-fidelity" rather than the distortion one gets with high-fidelity. It is useless to point out that "high-fidelity" means freedom from distortion, for freedom from

For a Glorious BIG TONE ON ANY STRINGED INSTRUMENT specify the Genuine AMPERITE "KONTAK MIKE" THE ONLY NO-DISTORTION "KONTAK MIKE"

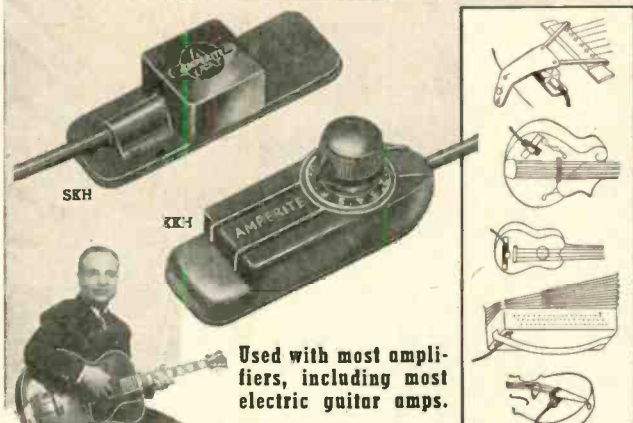

Anthony Amato, widely known as "the most versatile artist of the frets", is an enthusiastic user of Amperite Kontak Mikes.

The Amperite "Kontak Mike" improves the tone and volume of any Stringed or Fretted Instrument — also Pianos, Accordions, Harmonicas, etc. It is the only "Kontak Mike" that does not introduce peaks or distortion.

Model SKH, hi-imp..... List \$12.00

Model KKH
(with hand volume control)..... List \$18.00

AMPERITE STUDIO MICROPHONES at P. A. PRICES! Ideal for CLOSE TALKING or DISTANT PICKUP



AMPERITE CARDIOID
DYNAMIC MICROPHONE
Model's PGH-PGL..... List \$32.00

You can shout right into it, or stand away; in either case, the quality will be perfectly natural.
Model RBLG (200 ohms)..... List \$42.00
Model RBHG (hi-imp)..... List \$42.00



SPECIAL OFFER:
Write for Introductory
Offer, and 4-page
Microphone Folder 53-M.

AMPERITE Company, Inc.

561 Broadway • New York 12, N. Y.

In Canada: Atla; Radio Corp., Ltd., 560 King St., W., Toronto 28

Yours for the Aspiring

76 PAGE

ANTENNA CATALOG SECTION
as reprinted from Radio's Master

Antennas • Boosters • Accessories

Catalogs the products of 32 leading
Antenna and Accessory Manufacturers

FREE! See coupon

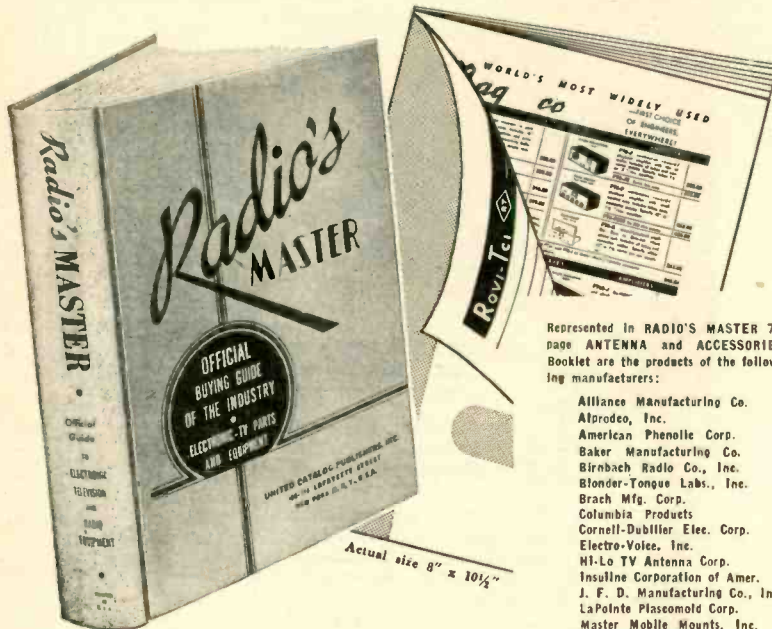

Represented in RADIO'S MASTER 76 page ANTENNA and ACCESSORIES Booklet are the products of the following manufacturers:

- Alliance Manufacturing Co.
- Alproco, Inc.
- American Phenolic Corp.
- Baker Manufacturing Co.
- Birnback Radio Co., Inc.
- Blonder-Tongue Labs., Inc.
- Brach Mfg. Corp.
- Columbia Products
- Cornell-Dubilier Ele. Corp.
- Electro-Voice, Inc.
- Hi-Lo TV Antenna Corp.
- Insuline Corporation of Amer.
- J. F. D. Manufacturing Co., Inc.
- LaPointe Plascomold Corp.
- Master Mobile Mounts, Inc.
- Mosley Electronics
- Peerless Products Industries
- Penn Television Products Co.
- Premax Products
- Radefco Manufacturing Co.
- Radlart Corporation
- Radio Corporation of Amer.
- Radio Merchandise Sales, Inc.
- Regency Division I.D.E.A., Inc.
- Walter L. Schott Co.
- South River Metal Prod. Co.
- Spirling Products Co., Inc.
- Technical Appliance Corp.
- Tel-A-Ray Enterprises, Inc.
- Telrex, Inc.
- Tricraft Products
- Ward Products Corporation

Actual size 8" x 10 1/2"

You can obtain without cost or obligation, a complete 76 page antenna catalog section as reprinted from the Industry's Official 1220 page Radio's Master, 17th edition.

Whether you buy, sell or specify, you will find this handy booklet extremely helpful for quick reference. It catalogs in detail the products of the leading Antenna and Accessory manufacturers with complete descriptions, specifications and illustrations.

This offer is made possible by a special arrangement between Audio Engineering and the publishers of RADIO'S MASTER. Fill in the coupon NOW and a copy will be sent you by return mail.

CLIP and MAIL TODAY!

AUDIO ENGINEERING
P. O. BOX 629, Mineola, N. Y.

Please send me, without cost or obligation, the 76 page ANTENNA and ACCESSORY Booklet reprinted from Radio's Master.

Name

Address

City Zone State

distortion in that sense only implies that scientific measurement does not reveal distortion. The non-musical scientist may "prove" that there is no distortion, but the musician will not be impressed with such a "proof." He will merely point out that it doesn't sound like the real thing, and that is enough for him.

Checking the Results

With this in mind we can now consider my presupposition that the speaker diaphragm is something flexible which flaps about in the air to produce a complexity of sounds. I have shown that mathematical analysis of this is impossible, but scientific experiment has been able to lay down certain desiderata. It has been shown, for example, that a restricted frequency response will not permit of satisfactory reproduction of music—there is lack of bass and wooliness owing to suppression of the higher harmonics of the instruments being "reproduced"; speech, also, is "plummy." Accordingly, for what is called high-fidelity reproduction, a frequency range of about 50 to 15,000 cps is postulated. But in addition to this there must be good reproduction of transient noises otherwise the reproduction will lack what is usually termed "attack." Apart from wide frequency response this requirement postulates a very low degree of inertia in the reproducing system, otherwise it will not be able to deal with sudden impulses without delay, or return to the normal sufficiently quickly to deal with the next impulse. If we assume that the design of the amplifier has been completed satisfactorily (and the design of this can be done mathematically, and tested scientifically, because it is designed to handle electrical currents which can be measured for amplitude, frequency, phase, and transient distortion) we are left with the problem of designing a physical body which has to produce audible sounds which can only be partially measured.

If the speaker cannot be designed by scientific methods it can only be done by trial and error, and this requires a knowledge of what is required, how it can be done, and how it can be checked. Leaving out the magnet system and the voice-coil assembly, we are left with the problem of designing a diaphragm which will flap about in such a way that the sum total of its flapping is the reproduction of all musical sounds within the prescribed limits without audible distortion. How this can be done does not come within the scope of this article, but how it can be checked has already been mentioned—by listening to it. You may object that it is not fair to condemn a certain technique without offering a replacement technique, and provided the terms of reference of the argument had not been laid down the objection would be valid.

Terms of reference were, however, laid down. They were: an injury into the contention that the perfect diaphragm should be an infinitely rigid disc of no mass is absurd and also my assertion that if such a diaphragm could be produced it could only reproduce a sine-wave. From this inquiry emerged an argument which suggests that the mathematical design of a loudspeaker is impossible, and if this is so, then

the thing can only be done by trial and error guided by practical experience. Finally, it can only be assessed by subjective artistic standards. That is the result of adopting my absolute presupposition, but as the two opposing presuppositions are by their very nature articles of belief, since there is no *a priori* knowledge to which you can refer, your acceptance of one or the other is a matter for your taste and logical conscience. But your choice will determine the final result.

In selecting a loudspeaker to entertain and instruct you you can, on the one hand, go to a great deal of trouble in finding out all about it in a technical way, having previously armed yourself with the technical specification of what is required electrically to create undistorted reproduction. You will demand response curves, figures for electro-acoustic efficiency, intermodulation distortion, and anything else that occurs to you, and when you have made your choice you will erect the reproducer and say "That is the last word on high-fidelity reproduction." You will, in fact have joined the ranks of what some people call "audiophiles," and you will be hurt and annoyed when some ordinary individual comes along, listens, and says "I think it is lousy." You will dismiss him as a man who knows nothing about musical reproduction.

On the other hand you can say "I do not believe that the sound of an orchestra can be defined by a mathematical equation. When I go to a concert I hear things which please me or annoy me, but whatever I hear is the result of people consciously making music. What I want in my home is as close an approach as possible to the sensation created in me when I go to a concert." And the only way you can assess the qualities of any equipment offered to you is to listen to it, taking very great care that you are comparing its performance with original music and not with other equipment. If this is how you select your equipment, then the very last place to go to is one of those "audio test rooms" wherein a dealer will let you hear twenty different speakers working on twenty different amplifiers. In such a place you will certainly be able to compare one equipment with another, but your ears will become so "conditioned" to the sound of an electronic device that you will forget what happens in real life. If you do not believe me, go and listen to all the equipment you can hear in any big city, try and carry it in your mind. And then go to a concert. The shock is profound. You will, in fact, realize, as others have done before you, that "high-fidelity" is getting farther and farther away from realism. Without the audio engineer you cannot have the foundations of realism, but without the musician you will remain an audiophile.

WHAT'S NEW?

See for yourself at the
**AUDIO FAIR-
LOS ANGELES**

Feb. 5, 6 & 7

Alexandria Hotel
Los Angeles, California

Stephens "500" SERIES GIVES NEW CONCEPT TO HIGH FIDELITY

• NEW 500 D DIRECT DRIVE AMPLIFIER AND MATCHING
500 OHM VOICE COIL SPEAKERS



500 D DIRECT DRIVE AMPLIFIER FINEST EVER OFFERED

Designed for use with speakers having 500 Ohm voice coil. Never before has such fidelity been possible. Stephens matching speakers with 500 ohm voice coil used in conjunction with the 500 D amplifier provide the finest reproduction of sound yet achieved. This is the first amplifier to successfully eliminate the output transformer thereby eliminating hum and distortion introduced by transformers. At full 20 watt, distortion is less than 1/4 of one percent. Phase shift is less than 15° at 20 c.p.s. (far less than can be obtained with a transformer.) Learn more about this outstanding development. Write for technical data.

List Price:
500D Amplifier, \$184.00

5106AX COAXIAL SPEAKER

This fine coaxial speaker reproduces true-to-life tones across the entire audio spectrum. Space saving compactness makes it the choice for most broadcast station monitoring and the finest set manufacturers. It is one compact assembly combining a 15" low resonate cone reproducer with a separate lightweight metal diaphragm and voice coil assembly coupled to an 8 cell horn with 40° x 80° dispersion.

Also has a 1200 cycle high pass filter. Power rating, 20 watts,* Impedance—500 ohms. Frequency Response—40 to 20,000 c.p.s. Diameter—15 1/4". Recommended for broadcast monitoring, motion picture sound, and especially FM and record reproduction. Available as a 16 ohm system, Model 106AX.



List Price: Model 5106AX . . . \$179.00
Model 106AX . . . \$166.00

For superior listening qualities be sure to get Stephens
Tru Sonic components . . . complete illustrated
catalog available on request.

EXHIBITING AT THE LOS ANGELES AUDIO FAIR

STEPHENS
TRU-SONIC

STEPHENS MANUFACTURING CORP.

8538 WARNER DRIVE • CULVER CITY, CALIF.

Equipment Report

SONOCRAFT FM TUNER

Compact new FM tuner offers advantages for installation in small cabinets, yet provides satisfactory reception even in fringe areas.

FOR high-fidelity radio reception, it is generally conceded that FM provides better quality and less distortion than AM, and listeners located in cities where FM stations carry the programs of local or network stations simultaneously usually prefer to use only one type of receiver—FM. Actually, a good AM receiver is capable of high-quality reception, particu-

larly when the receiver is of the t.r.f. type, but while such receivers are satisfactory in areas close to the transmitters, they are not nearly so desirable at long distances, because of atmospheric noise. Therefore, the listener desiring good quality will usually turn to FM, even if he may be in what is commonly termed a "fringe" area.

FM reception in outlying areas offers a problem to many listeners, however, due to lack of sufficient signal strength. The Sonocraft FM tuner, however, has excellent sensitivity, and under test conditions at a location 40 miles from New York performed very satisfactorily.

The tuner is of conventional design, except for the r.f. and oscillator circuits, which are slug-tuned. It employs a ganged assembly of cores which move in and out of the coils, and the construction is such that trimming may be accomplished at both ends of the tuning range. The i.f. amplifier consists of three stages, followed by two limiter stages and a discriminator. The 6AG5 r.f. stage provides plenty of signal sensitivity, the figure claimed by the manufacturer being 5 microvolts for 20-db quieting. The bandwidth at 6 db down is 200 kc, with sufficient selectivity

to reduce adjacent channels by 50 to 60 db.

The tuner is equipped with an effective a.f.c. circuit, which may be switched on or off from a front panel control. With the a.f.c. switched off, the drift is excessive for the first ten minutes of operation, but thereafter the drift is negligible over a period of hours.

One feature of the tuner is the indicator, which is simple and of clever design. A 6J6 serves as the indicator driver, being connected as a v.t. voltmeter tube. The indicator tube is an NE-51, connected between the plates of the 6J6. One plate of the NE-51 glows when the set is tuned on one side of the correct frequency, and the other glows when the set is tuned to the other side. When the set is correctly tuned, neither plate glows—from which the tuning indicator derives its name, "Blackout."

Because of its compactness, this tuner is adjudged to make a satisfactory addition to a home music system in which only FM is desired and which must be housed in small cabinets. It is self powered, and is not equipped with a volume control, since the tuner output is usually fed directly into the control amplifier.

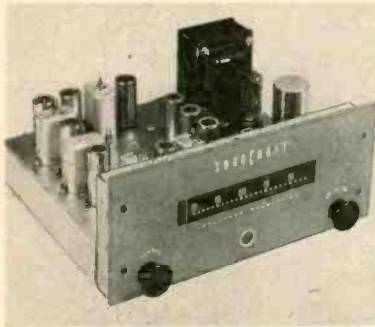

Fig. 1. External appearance of the tuner, which has a panel only 10-in. wide and 4 1/4 in. high.

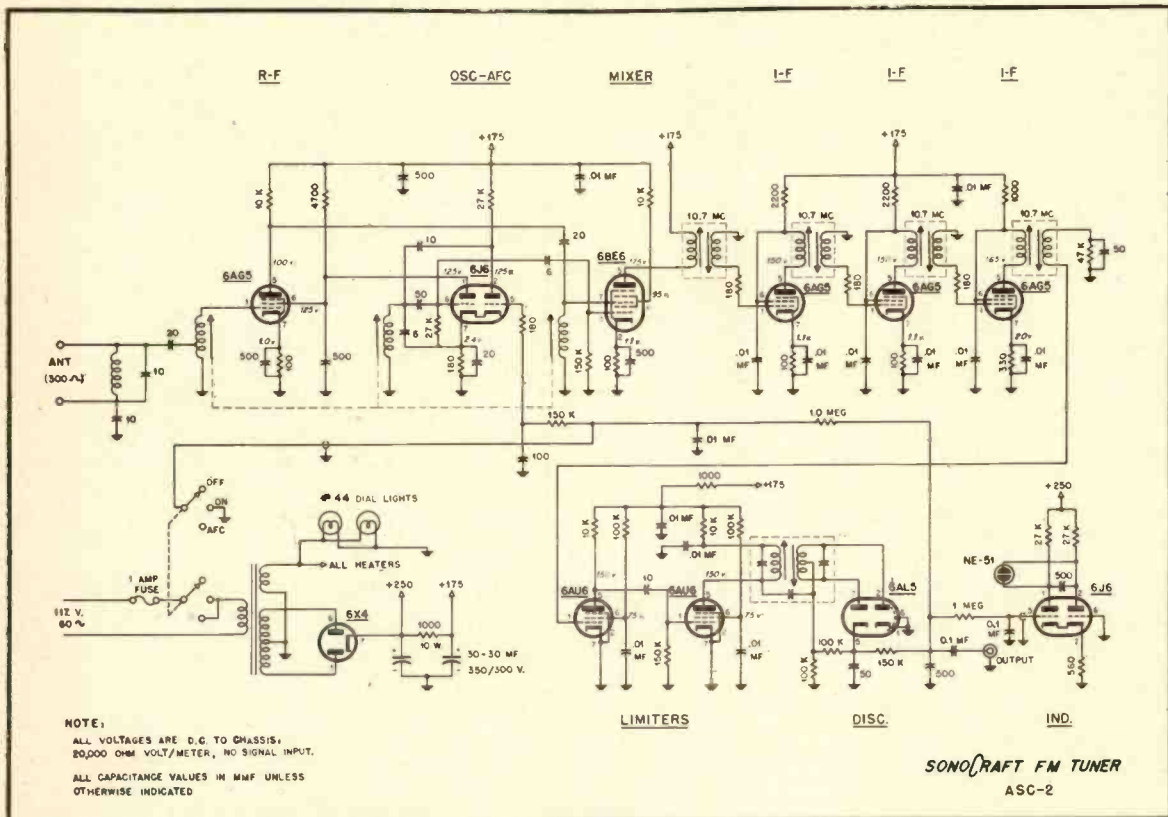

Fig. 2. Complete schematic of the Sonocraft FM Tuner, with operating voltages.

BINAURAL OR STEREOPHONIC?

[from page 24]

Something should be said about suitable tape recording equipment. Figure 4 shows a typical two-channel portable recorder. One case contains the tape transport mechanism, another contains two separate record and simultaneous playback amplifiers, one set for each of the two tracks. The third contains the power supplies for the amplifiers. The erase/bias oscillator, mounted in one amplifier, supplies bias directly to one channel and through a buffer amplifier to the other, so that the same bias frequency is used in each recording head, thus eliminating the beat frequency which would result from using two separate oscillators of approximately the same frequency. Figures 5 and 6 show the head assembly with a full track erase head, two side-by-side record heads which record two simultaneous tracks, running parallel along the length of the tape, and two appropriate pickup heads. Tape motion is from left to right across the heads. Thus the tape is first erased, then recorded upon, and then monitored a fraction of a second later over the playback system. The record heads are well shielded between the two and have 50 db attenuation on cross-talk between channels. The gaps of both the record and playback structures are critically aligned in parallel so that the time error between the two separate tracks is less than .00003 sec. at 15 in./sec. tape speed, or .00006 sec. at 7½ in./sec. This has an interesting sidelight. Tapes recorded stereophonically (or binaurally) on this type of inline gapped head may be played back on a standard full-track reproducer in an entirely satisfactory one-channel manner. This makes it possible to produce pre-recorded stereophonic tapes which may be played on either a stereophonic or a standard playback machine.

It will be noted that binaural headphone listening to orchestral music, for example, appears to give a much greater sensation of a completely "new" way of listening, and that loudspeaker stereophonic listening (correctly done) is not as astonishing. Headphone binaural listening is best for many special investigative problems. But speaker reproduction should sound more natural than the headphone method because we are used to being in a room-acoustic environment. In fact, it is for this very naturalness that we search.

The author is indebted to his early teachers in acoustics, his many customers, his associates, and several midwest university musical organizations for background and experimental set-ups which have led to the conclusions set forth above. Some of the conclusions reached might be somewhat controversial. Much three-dimensional acoustics still is. As one acoustician has said: "In no branch of science is the theory so simple and the measurement so difficult."

5687 Basing

The Tung-Sol 5687—used in the Kiebert version of the "Williamson Amplifier Up-To-Date" described in the August issue—is similar to the 12AU7, but is not directly replaceable for the latter tube. The principal difference of importance is the basing, with that for the 5687 being shown at the right. Note that the heater center tap is on terminal 8, rather than on terminal 9 as in the 12AU7. Note also that the connections to Section 1 of the tube are entirely different.

While the 5687 has certain advantages over the 12AU7, the user is cautioned not to attempt to replace directly without change in socket connections.

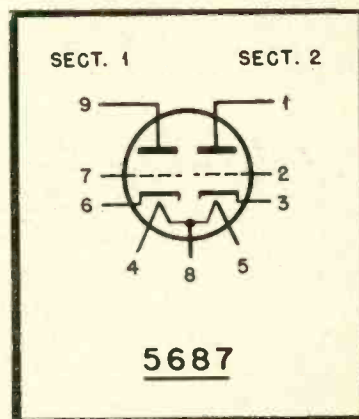

HYCOR

TYPE 4200

Sound Effects Filter



This unit has been developed to meet present day requirements for compactness. The filter requires only 3½ inches of rack space.

Features:

- **LOW HUM PICKUP** through the use of toroid coils. The unit may be used in circuits having signal levels as low as -40 dbm without the necessity for taking special precautions against hum pickup.
- **LOW DISTORTION:** The filter may be used at levels up to plus 20 dbm with negligible intermodulation distortion.
- **RELIABILITY:** All capacitors and inductors are hermetically sealed for lifetime service. Aging effects are negligible.

General specifications:

- DIMENSIONS:** Standard rack panel, slotted, 3½" high. Maximum depth 7½".
- CONTROLS:** Low frequency cutoff selector knob, high frequency cutoff selector knob, on-off key.
- RANGES:** Both low and high frequency cutoff controls cover 100, 250, 500, 1000, 2000, 3000, 4000 and 5000 cycles.
- ATTENUATION:** Approximately 16 db, per octave on both high and low frequency cutoff points.
- IMPEDANCE:** 500/600 ohms, in-out.
- FINISH:** Engraved panel finished in medium gray baked enamel. (Special colors available upon request.)

The filter has standard input and output jacks located on the front panel in addition to the terminal block at the rear.

HYCOR

Company, Inc.

Send for Bulletin S

11423 VANOWEN STREET, NORTH HOLLYWOOD, CALIFORNIA • SUNset 3-3860

Manufacturers of Toroid Inductors, Decade Inductor Instruments, Wave Filters, Resistive Networks, and Precision Resistors

Eastern Representative: Burlingame Associates, 103 Lafayette Street, New York 13, New York

NEW PRODUCTS

● **New Turnover Cartridge.** Pickering's latest contribution to the technique of re-creating recorded music is their new Model 260 Turn-Over Pickup. The factors which have earned the present high reputation for Pickering Audio Components are inherent in the development, engineering,

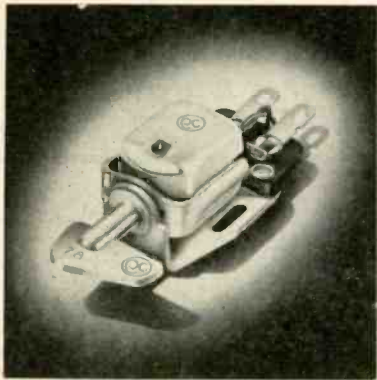

and manufacture of this new model, which has an output of 30 millivolts at a stylus velocity of 10 cm. per sec., and which mounts easily in any type of arm. Detailed literature may be obtained by writing Pickering & Company, Inc., Oceanside, N. Y.

● **Radio-Phonograph Cabinet.** A compact, convenient, and well-made piece of furniture is currently being offered by Jeff Markell Associates, 108 W. 14th St., New York 11, N. Y. Featuring a modern design in 12 finish colors on birch, mahogany, korina, walnut, and oak, these cabinets provide space for changer, tuner, and am-

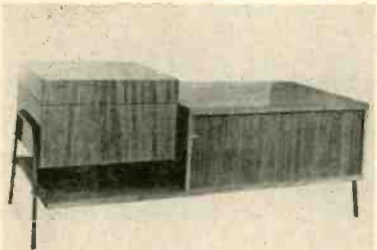

plifier, and are of modern design, using half-inch square wrought iron legs. In addition to its duty as a housing for audio system components, the RC-118 also serves as an attractive cocktail table. The cabinets are available from dealers and jobbers.

● **TV Signal Range Calculator.** The new Pioneer calculator for determining the signal range of TV stations quickly shows the approximate Grade A, Grade B, and "Principal City" coverage for all VHF and UHF television channels. Resembling a slide rule in appearance, the instrument readily shows approximate field strength



in microvolts-per-meter for distances up to 100 miles from a TV transmitter. Coverage radius is read directly, and with one rule setting, for stations operating with ERP from 10 to 1000 kw, and for antenna heights up to 3000 feet. Pioneer Electronic Supply Co., 2115 Prospect Ave., Cleveland 15, Ohio.

● **45-RPM Recording Disc.** Said to be the first 45-rpm recording blank to be marketed commercially, the new Soundcraft "45" is made with a perforated center which permits use of the disc with all types of recorders and players. With the center section in place, the disc fits the



conventional recorder spindle. When the section is punched out, the disc is suited for use with standard 45-rpm turntables. The "45" is now in production and available for delivery. Reeves Soundcraft Corporation, 10 E. 52nd St., New York 22, N. Y.

● **FM Tuner.** An all-triode r.f. section and dual cascade limiters are among the features of the new Browning Model RV-31 FM tuner. Input signals of 3 microvolts will afford 20 db quieting; a.f.c. locks the local oscillator into correct tuning and may be switched off if desired. Selector

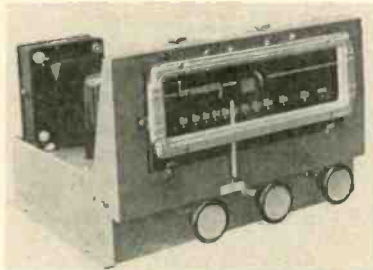

switch permits FM, TV, Phono, or recorder playback to be fed through the tuner volume control to the basic amplifier when desired. Extremely well-adapted to custom installation, the RV-31 is only 11 in. wide, 9 3/4 in. deep, and 6 3/4 in. high. Full 15-kc audio output is fed through a cathode-follower output stage, thus permitting long cable runs without affecting high-frequency response. Power supply is self-contained. Browning Laboratories, Inc., Winchester, Mass.

● **Noise and Distortion Analyzer.** Design engineers in many phases of the electronics industry will welcome the Model ND-110 analyzer recently introduced by Empire Devices, Inc., 33-25 Bell Blvd., Bayside, N. Y. In essence the ND-110 is a harmonic wave analyzer capable of measuring the mean power of complex

signals (broad band), and the distribution of this power within the ultrasonic frequency spectrum (narrow band). It may also be used to determine signal-to-noise ratio, distortion and intermodulation characteristics of telephone transmission equipment and various ultrasonic

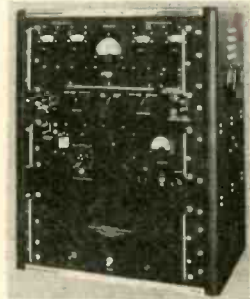

devices. Frequency range is 4 to 110 kc. The local oscillator is housed in a thermostatically controlled oven for maximum stability.

● **High-Quality Cabinet Speakers.** An exponential horn, compactly folded within an enclosure, assures excellent audio quality in a new series of speaker assemblies recently announced by White Sound, Inc., Suite 1105, 105 W. Madison St., Chicago, Ill. Available in four sizes, the new speak-

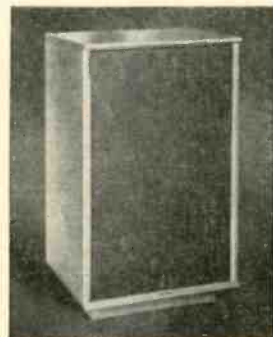

ers are designed on the principle that there must be a proper relationship between driver and housing if ideal performance is to be achieved. As a result, all cabinets are supplied complete with a speaker unit which affords optimum audio quality. Folded horns are within 2 per cent of a true exponential formula. Corner installation is not necessary.

● **Ferrite Recording Head.** Manufacturers of tape recorders will find interest in a new recording head which makes use of

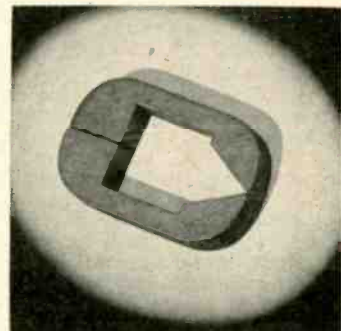

a Ferroxcube non-metallic ferromagnetic core. A new material, designated Type 1-20-1, has been developed especially for use with magnetic recording equipment. It is very homogeneous and is more nearly free from voids and cracks than most commercially available ferrites. Technical information will be supplied upon letterhead request to the Application Engineering Department, Ferroxcube Corporation of America, 241 Marshall St., North Adams, Mass.

• **Junction Transistors.** The immediate availability of two PNP Germanium Junction Transistors types CK721 and CK722 has just been announced by the Receiving Tube Division of Raytheon Manufacturing Company, 55 Chapel St., Newton 58, Mass.



Both of these types of transistors have noise factors averaging 22 db at 1000 cps, with the type CK721 showing an average power gain of 38 db and type CK722 showing an average gain of 30 db. The units require a volume of 0.03 cu. in., and the leads may be soldered or welded into the circuit or cut for insertion into standard subminiature sockets. Both types are described in data sheets now available from Raytheon's Technical Information Service, at the above address.

• **LP Test Recording.** There is hardly any turntable or record-changer test which cannot be conducted with a new disc recently produced by The Dubbings Co., 41-10 45th St., Long Island City 4, N. Y. The record consists of two identical sides,



each of which contains 20 test bands. In addition to frequency checks from 30 to 12,000 cps, test bands are available for determining amount of rumble, correctness of stylus pressure, and extent of wow. An excellent set of instructions supplied with the record greatly extends its usefulness.

Leonard Presents . . .

A WELL BALANCED SYSTEM!

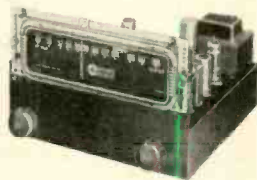

BOGEN FM-801 FM TUNER

Now . . . the perfect unit for adding FM to an AM system! The Bogen Tuner employs a 3 gang tuning condenser . . . a dual eliminator in a

Foster-Sealey discriminator, and separate AFC circuit that assures easy tuning and absence of drift. Light-edged slide rule dial for quick station selection. Complete FM coverage (88-108 MC) with a frequency response of ± 1 db 50-15,000 cps. Six micro volts sensitivity make it ideal for fringe areas. Power required: 117 volts, 60 cycle, 50 watt. Size: 20" x 9" x 7"; weight: 12 lbs. Complete with 8 tubes, 1 rectifier. **\$72.22 net**

BELL 2200

20 WATT AMPLIFIER



Under development for over a year, the Bell 2200 is an extremely versatile and flexible machine. SPECIFICATIONS: Frequency response:

$\pm .05$ db 20-20,000 cps.; Hum Level: 80 db below; Output impedance: 4, 8, 16 ohms; Controls: 5 position

equalizer, 5 position selector, volume, bass, treble, on-off switch; 7 tubes, Power requirement: 117 volts, 50-60 cycle, 150 watts. Size: 8 $\frac{3}{4}$ " x 7 $\frac{3}{8}$ " x 16". Weight, 24 lbs.

\$97.31 net

JENSEN H-222 COAXIAL LOUD SPEAKER

Specially designed to bring improved performance to those applications where speaker size is limited to enclosure limitations. A new high in 12" size performance! SPECIFICATIONS: Power output: 25 watts; Frequency range: 32-17,000 cps; Voice coil impedance: 16 ohms; Size: 12 $\frac{1}{8}$ " x 8 $\frac{1}{4}$ ". Weight: 12 lbs. Complete with H-F balance control.



\$48.71 net

GARRARD RC-80

3 SPEED RECORD CHANGER



Here's masterful custom performance for 7", 10" or 12" records and 33-1/3, 45 and 78 rpm speeds. Fully automatic including switch-off at end of last record and automatic return of tone arm to rest position. Easily adapted

for either 110 V or 220 V current. Complete with automatic 45 rpm spindle and 2 empty cartridge shells for mounting G. E., Audax, Clarkstan or Pickering cartridges.

\$41.45 net

MM Magnetic turnabout cartridge G. E. RPX-050 mounted in Garrard shell . . . 8.37

Write for FREE Hi-Fi Guide, "MUSIC FOR MODERNS"

Mail & Phone Orders Filled—25% Deposit, Balance COD



LEONARD-RADIO-INC.

69 CORTLANDT ST., NEW YORK 7, N. Y.

Electronic Equipment

CORTLANDT 7-0315

The House Built on Service

SOUND HANDBOOK

(from page 32)

amplitude modulation occurs twice per low-frequency cycle. The intermodulation frequencies in this case will consist of the sum of and difference between the high-frequency signal and double the frequency of the low-frequency signal, the latter figure representing the rate of modulation of the envelope.

Harmonic distortion is described quantitatively as the ratio, in percentage, between the r.m.s. amplitudes of the spurious harmonics and of the fundamental. Each order of harmonic may be listed separately, or the total distortion may be expressed in a single percentage representing the graphical addition of all component orders. The total will thus be less than the arithmetic sum of its various parts. Higher orders of harmonic distortion have an especially great irritation value.

Figure 8-6 is a table listing the maximum harmonic distortion allowed broadcast stations by the FCC. Modern high-quality recording equipment, pickups, and amplifiers in particular are able to do considerably better than the FM performance standards. These standards are still too high for loudspeakers, however. Speaker distortion data is rarely published, but when such data does appear it reveals the fact that the very best and expensive loudspeakers create distortion, at certain lower portions of the

frequency spectrum and at moderately high power levels, of the order of 5 per cent.

Intermodulation distortion is also indexed as a percentage ratio, that between the amplitude of the unmodulated high-frequency carrier and the amplitude of the low-frequency modulating envelope. This is the same figure as the percent of modulation referred to in AM transmitter work. The ratio between harmonic and intermodulation percentage is not fixed, and depends upon factors such as the signal frequencies, their relative intensities, and the type of non-linear distortion involved, but usually the intermodulation distortion is between three and four times the harmonic distortion. It will be seen that multichannel systems, in which the low and high frequencies are not allowed to pass simultaneously through the same distorting system, discriminate against the intermodulatory effects of harmonic distortion.

Power Capability

The generally accepted goal of a home reproducing system, as far as power capability is concerned, is to be able to create intensity levels of sound in the living room equal to the intensity level of sound at a good seat in the concert hall. This is not as overpowering an intensity as it might at first seem; the relatively quiet coughs and sneezes of one's neighbor at the concert hall may be heard with ease during the performance.

The acoustical output of the repro-

ducing system is spread over a much smaller area, and is therefore able to recreate concert hall intensity levels with much smaller amounts of power. The acoustical power of a seventy-five piece orchestra may approach peak instantaneous values of 75 watts, which, with a typical home speaker system of 5 per cent efficiency, would require an instantaneous electrical power capability of 1,500 watts to reproduce. We are obviously not concerned with absolute values of power, however, but with sound intensity, in watts per square centimeter (watts/cm²).

The walls and other surfaces of a room are partially reflecting, so that sound directed against these surfaces will not disappear immediately after the source stops, but will be reflected back and forth, losing part of its energy with each reflection. The sound will take a certain amount of time to die away; the time required for the steady-state intensity to decay to a value one millionth of the original (60 db down) is called the *reverberation time*. It is directly proportional to the volume of the room and inversely proportional to the total absorption present.

The acoustical power required to create a given intensity level is inversely proportional to this reverberation time, because new sound energy being pumped into the room finds some of the old sound energy still working. Thus the absorptive materials in a room require a source of sound to radiate greater power for the same intensity level. Figure 8-7 is a

Fleetwood

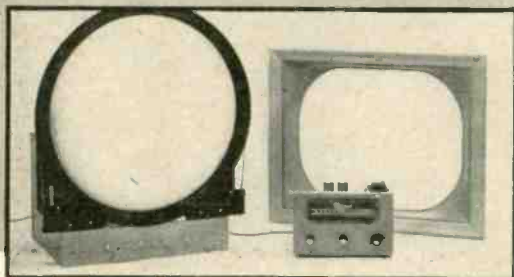

THE FINEST IN Remote Control TELEVISION RECEIVERS

with High Fidelity Audio Output

Complete 2-Chassis System Featuring The New 27" Rectangular Picture Tube

ALSO AVAILABLE FOR 21 AND 24 INCH PICTURE TUBES

For the finest in television picture quality, with the convenience of electronic remote control, enjoy the many features of the Fleetwood. A complete two chassis, full remote control, television system, built to professional standards which provides high fidelity audio output to match the finest home music systems.

The separate tuner chassis, with edgelit dial and individual channel pilot lamps, includes off-on, volume, picture channel selection and fine tuning controls. The tuner is of the Super Cascode type, completely adaptable to UHF by

simple interchange of strips. UHF provision on tuner dial. Four I. F. Stages and full 4 megacycle bandpass. Separate cathode followers for audio and video. Two audio outputs: —4 watts for loudspeaker or high impedance for connection to existing amplifier.

Both Tuner and Picture Chassis attractively finished in gray and black baked lacquer.

ALSO AVAILABLE WITHOUT REMOTE CONTROL—THE FLEETWOOD 610

See Us At The West Coast Audio Fair in Los Angeles, Room 623

SEE YOUR LOCAL JOBBER OR WRITE
CONRAC, INC. ★ Since 1939 ★ Glendora, California

chart indicating the acoustical power required to produce intensity levels of 70 to 100 db (above threshold) for various auditorium or room volumes with typical reverberation characteristics. Since the desired concert hall levels may approach peaks as high as 100 db (Fig. 8-1), a room 10 x 15 x 20 ft. would require a maximum acoustical output of 0.45 watts. With a loudspeaker system of 5 per cent efficiency, this output would call for an amplifier with a maximum power capability of 9 electrical watts. Larger rooms, a great deal of sound absorbent furnishings, and less-efficient speakers increase this requirement.

The power rating is determined by the number of watts that can be drawn from the system without distortion exceeding a specified amount. This rating tends to drop at the frequency extremes. Figure 8-1 shows that such a deficiency may be offset by the reduced intensity levels of orchestral music in the end frequency regions.

Dynamic Range

The dynamic range required for the reproduction of orchestral music with perfect subjective fidelity is about 70 db (see Fig. 8-1). The upper limit of the dynamic range of reproducing equipment is determined by the power capability of the system (in the case of disc recording by the maximum groove deviation allowable); the lower limit is determined by the level of noise, which would mask low-intensity sounds. Older records used a dynamic range severely limited by considerations of over-cutting of grooves and of surface noise, and the dynamic range of AM broadcasts is limited at each end by modulation percentage and signal-to-noise ratio respectively. These program sources therefore have a restricted range, often 40 db or less.

The use of expander circuits, which increase the gain of the amplifier to loud signals and restore some of the dynamic range lost in the original compression, was fairly common a few years ago. Although the characteristics of the expansion could not be perfectly matched to those of the original compression, the better circuits afforded considerable over-all improvement. Today, because of the extended dynamic range of records and of FM broadcasts, approaching the full requirement, the use of expanders has decreased.

Noise Level

The spurious noise components introduced into the output of reproducing systems include hum, thermal noise, microphonics, record surface noise, and turntable rumble. The annoyance value of noise is not determined exclusively by its relative amplitude to the signal, but also by other of its characteristics, particularly frequency content (due to the increased hearing sensitivity at certain parts of the spectrum described by the Fletcher-Munson effect). Noise of very low frequency may be inaudible but may create intermodulatory products in in-

teraction with the signal. Noise level is normally described in terms of the ratio to the maximum signal amplitude, as this rating is more accurately indicative of annoyance value in a given situation than a rating in terms of absolute power would be. Figure 8-6 shows the maximum power level of noise allowed broadcast stations by the FCC. When the noise level is 60 db below the maximum signal power the absolute value of the hum in microwatts is equal to the value of the signal output in watts.

Due to the influence of acoustical conditions, hearing characteristics, and other such factors on the irritation value of noise, a listening test may in some situations be superior to a quantitative

measurement, unless the quantitative results are properly weighted.

Binaural Reproduction

Sound which originates from an orchestra approaches the listener from several directions. The path length to each ear is therefore not the same, and in addition the waves are diffracted around the head, so that the version of the sound which each ear receives is slightly different in time, phase, intensity, and even timbre (this last due to the frequency discrimination of diffraction). Experience has enabled our perceptive mechanism to interpret these differences in terms of directional loca-

**From
Station Break
to Feature . . .
the NEW
"BALANCED"
TV Tripod
is doing a
whale of a job
every day!**



**"BALANCED"
TV TRIPOD**
mounted on
3-wheel
portable
collapsible
dolly
illustrated.



We THREW THE book away and engineered a brand new "BALANCED" Tripod for every photographic and video need. The result—a revelation in effortless operation, super-smooth tilt and 360° pan action.

PERFECT BALANCE prevents mishap if the lock lever is not applied. Quick release pan handle locks into desired position. Mechanism is enclosed, rustproof, needs no lubrication. Tension adjustment for Camera Man's preference. Built-in spirit level. Telescoping extension pan handle. We defy you to get anything but the smoothest, most efficient operation out of this tripod beauty.

WE CALIBRATE LENSES . . . Precision "T" STOP CALIBRATION of all type lenses, any focal length. Our method is approved by Motion Picture Industry and Standard Committee of SMPTE. Lenses coated for photography. Special TV coating.

WE RENT AND SERVICE
CAMERAS * MOVIOLAS *

DOLLIES . . . Complete line
of 35mm and 16mm equipment available for rental.

MITCHELL: Standard, Hi-Speed, BNC, NC, 16mm. **Bell & HOWELL:** Standard, Shiftover, Eyemos. **MAURER:** 16mm Cameras. **ARRIFLEX.** MOVIOLA: Editing machines, Synchronizers.

WE DESIGN and manufacture Lens Mounts and camera equipment for 16mm — 35mm and TV cameras.

FRANK C. ZUCKER
CAMERA EQUIPMENT
1600 BROADWAY NEW YORK CITY

IF YOU WORK WITH FILM . . .
It will pay you to get to know us. The country's foremost professionals depend upon our portable, versatile, adaptable equipment.



At your age!

If you are over 21 (or under 101) it's none too soon for you to follow the example of our hero, Ed Parmalee (above) and face the life-saving facts about cancer, as presented in our new film "Man Alive!"

You and Ed will learn that cancer, like serious engine trouble, usually gives you a warning and can usually be cured if treated early.

For information on where you can see this film, call us or write to "Cancer" in care of your local Post Office.

American Cancer Society



tion of the source or sources. Monaural reproduction from a single reproducing source eliminates this factor of realism, and has a definite effect on the illusion created, although there may be differences of opinion on the importance of the musical values associated with the loss.

The lost illusion may be restored, to a greater or lesser degree depending upon the method used, by stereophonic or binaural reproduction. A practical binaural system that is perfect can only work through earphones. Two recording microphones are mounted as though each were one human ear; the sound received by each is recorded separately, and each recorded channel is played back into its corresponding left or right ear-piece. In this way each ear receives a version of the music with just those characteristics that the left or right-side version would have contained in the concert hall.

Since earphones are much less convenient than loudspeakers, most practical stereophonic systems are designed for speakers. Each channel no longer represents the sound received by each ear, but the sound coming from the left or the right of the hall, all of which is received by both ears. This arrangement, for accuracy of stereophonic effect, would require many channels and a careful arrangement of the speaker array calibrated to the original layout of instruments. Such a procedure is obviously impractical except for the thea-

ter, and typical stereophonic systems use two channels and two permanently mounted loudspeakers. The results are a compromise but nevertheless afford an appreciable increase in "liveness."

Binaural demonstrations with earphones are always much more dramatic than those with loudspeakers. The reason for the greater illusion is described above, but there is another factor that increases the contrast between the monaural and binaural sound. Single-channel reproduction through earphones creates an artificial and impossible acoustical condition; each ear receives the identical sound at the same instant. Because of the fact that the normal left-right differences associated with diffraction around the head and reflection from room surfaces are eliminated when the ears are covered, such reproduction is unusually "flat", even when compared to that of a single loudspeaker. The contrast is thus widened by a particularly weak monaural standard.

GO WEST!

It's the West Coast

AUDIO FAIR

Feb. 5, 6, 7

Alexandria Hotel

Los Angeles, California

ORDER NOW!

1952 Bound Volumes—\$8.95

(Outside U.S.A. add 75 cents postage)

Over the years, **AUDIO ENGINEERING** has proven itself a valuable reference work worthy of a permanent place in your library. Many 1952 issues are already exhausted but you may have a complete bound volume of new copies for the entire year if you order now.

For the years to come—

Subscribe to **AUDIO ENGINEERING** on the combination offer which includes a bound volume at the end of the year. Each month you receive the magazine by mail as usual—read it, cut out coupons to your heart's content, mark on the pages as much as you like. Around January 15, 1954, you receive a fresh, new, bound volume of 1953 issues—no creases, no dog-eared pages. The cost?—only \$10.00 per year, a saving of \$1.95 over the price of the bound volume and the one-year subscription. Same offer, for two years, \$18.50.

(Canada and Pan-American Union—1 yr. \$11.00, 2 yrs. \$20.00; all other foreign—1 yr. \$12.00, 2 yrs. \$22.00)

Dept SV,

AUDIO ENGINEERING,

P. O. Box 629, Mineola, N. Y.

This offer expires

February 1, 1953

Enclosed is my check (or money order) for \$..... for copies of the 1952 Bound Volume of **AUDIO ENGINEERING**, to be delivered about January 15, 1953.

Enclosed is my check (or money order) for \$..... for a new renewal subscription for one year, plus a 1953 Bound Volume which will be delivered without further charges approximately January 15, 1954.

Enclosed is my check (or money order) for \$..... for a new renewal subscription for two years, plus a 1953 Bound Volume which will be delivered without further charges approximately January 15, 1954, and plus a 1954 Bound Volume to be delivered about January 15, 1955.

Name

Address

City Zone State

NEW LITERATURE

• **Engineering Products Department, RCA Victor Division**, Camden 2, N. J. has produced a full-color sound film titled "You Are the Producer," which demonstrates and explains how educators, industrial training groups, home movie makers, etc., can record their own sound on 16-mm. film at nominal expense and without laboratory processing. The 12-minute film features the RCA "400" magnetic recorder-projector, in an interesting dramatic sequence based on the ability of the unit to record on magnetic track, play back, erase, reproduce both optical and magnetic track, and operate at sound or silent speed. Information concerning use of the film for showing before interested groups may be obtained from any RCA visual products distributor, or by mailing an inquiry to the address shown above.

• **Thordarson-Meissner**, Mt. Carmel, Ill., is now distributing the company's new general catalog No. 53-A, a complete listing of all items manufactured under the Meissner trade mark. Many new products are shown for the first time, including a 10-watt high-fidelity amplifier and a transmitter kit for novices. A special section is devoted to receiver and amplifier kits. Copy will be mailed free for the asking.

• **General Electric Company, Tube Department**, 1 River Road, Schenectady 5, N. Y., announces availability of a new booklet describing the essential characteristics of G-E Five Star miniature and subminiature high-reliability tubes. Included in the data are the specific differences between individual Five Star tubes and their standard-counterparts. When writing specify Publication ETD-548-A.

• **McIntosh Laboratory, Inc.**, 320 Water St., Binghamton, N. Y., will mail free a new 32-page booklet titled "Lost Instruments," which makes use of cartoons to explain the whys and wherefores of high-quality audio equipment. Shown graphically are the meanings of such technical terms as intermodulation, harmonic distortion, band width, etc. An informative publication for both beginners and veterans in the audio field. Write for it.

• **Gustin-Bacon Manufacturing Co.**, 210 W. 10th St., Kansas City, Mo., is introducing Ultrafine, a new thermal and acoustical insulation, with a handsome 4-page folder which includes illustrations of the product in use, as well as tables listing thermal and acoustical efficiency. Ultrafine is made of extremely fine, blown glass fibres, and can be obtained in a variety of facings.

• **Automatic Electric Co.**, 1033 W. Van Euren St., Chicago 7, Ill., describes and illustrates a complete line of telephone-type relays including hermetically-sealed subminiature and plug-in types, in a colorful new 12-page brochure designated as Circular 1702-A. This is one of the finer examples of industrial publishing to cross this desk in many moons. If you use small relays, you will find a copy of great value.



Employment Register

POSITIONS OPEN and AVAILABLE PERSONNEL may be listed here at no charge to industry or to members of the Society. For insertion in this column, brief announcements should be in the hands of the Secretary, Audio Engineering Society, P. O. Box 12, Old Chelsea Station, N. Y. 11, N. Y., before the fifth of the month preceding the date of issue.

★ Positions Open • Positions Wanted

★ **Audio Systems Engineer.** Opportunity in new Audio Systems Section to create new products in professional and reproducing equipment. Telephone Mr. Marshall, Independence 3-2100 days, FLoral Park 2-0578 evenings. Fairchild Recording Equipment Corporation, 7th Avenue and Powell's Cove Road, Whitestone, N. Y.

You are cordially invited to attend the first 1953

AUDIO FAIR LOS ANGELES

Sponsored by the AUDIO ENGINEERING SOCIETY
in conjunction with its Los Angeles Section Technical Sessions

HIGH FIDELITY audio equipment and home music components to be demonstrated and displayed for lovers of high-quality reproduction, audiophiles, sound enthusiasts, recordists, FM-AM-TV electronic engineers, distributors, dealers and technicians.

YOU WILL SEE—HEAR—ENJOY the largest and most concentrated exhibition of audio equipment under one roof—featuring the latest products and newest developments of more than 75 nationally known manufacturers.

ADMISSION FREE TO ALL EXHIBITS



ALEXANDRIA HOTEL • LOS ANGELES

SIXTH AND SEVENTH FLOORS

FEBRUARY 5 • 6 • 7, 1953

For further information, write:

William L. Cara, Fair Manager • 4245 Normal Ave., Los Angeles 29, Calif.
Richmond 7-3196 Olympia 4988

BUILD YOUR OWN Heathkit TEST EQUIPMENT

Heathkits are completely engineered instruments supplied unassembled. Every kit goes together smoothly and easily. All drilling, punching, and painting has already been done for you. All parts are furnished and are of highest quality.

Detailed construction manual shows clearly where each wire and part goes and tells exactly how to build the kit. Write for free catalog.



AUDIO GEN. KIT
\$29.50



R. F. SIGNAL GEN. KIT
\$19.50



5" SCOPE KIT
\$43.50



T.V. ALIGN. GEN. KIT
\$39.50



SIGNAL TRACER KIT
\$22.50



VACUUM TUBE VOLTMETER KIT
\$24.50



BATTERY ELIMINATOR KIT
\$24.50



IMPEDANCE BRIDGE KIT
\$69.50



TUBE CHECKER KIT
\$29.50



GRID DIP METER KIT
\$19.50



CONDENSER CHECKER KIT
\$19.50

HEATH COMPANY
BENTON HARBOR 12, MICHIGAN

EXPORT AGENT
ROCKE INTERNATIONAL CORP.
13 East 40th Street
NEW YORK CITY (16)



Attenuators

Precision and General Purpose, "T" Type

Both with impedance range from 30 to 600 ohms. Precision resistors held to within $\pm 1\%$ accuracy . . . general purpose within $\pm 5\%$. Also Bal. H types.



Range Extending

For use with all makes of V.U. and D.B. meters. All resistors within $\pm 1\%$.



Potentiometers

Precision and General Purpose grid control types with non-inductive, wirewound resistors. Also dual precision wirewound grid potentiometers.



Write for Complete Catalog

N. Y. Stock:
Audio & Video Products Corp. • 730 Fifth Ave., Plaza 7-3091



Export Agents: Frazer & Hansen, Ltd. • 301 Clay St • San Francisco, Calif. U.S.A.

FLEXIBLE CHANNEL

(from page 29)

because the final product would be on optical film and after making comprehensive listening tests it was decided that normal optical cut-offs would be useful for magnetic recording also. Due to the increased amount of recording being done, everything is first put on magnetic and then transferred to optical and held until the picture "answer" prints are delivered. In this way the advantage of magnetic is utilized as a safety, as well as for a temporary reference; it is erased after the "all clear" is given. Some time ago, the inventory of magnetic film increased to such an amount—because of the increase of jobs waiting for answer prints—that the system was later modified and magnetic film is erased and made available for re-use immediately after getting the "go ahead" from the editorial department when they are satisfied they have the proper footage to cover their needs.

As far as the actual operation of the channel is concerned, it was made as straightforward an operating chore as possible so as to eliminate mistakes, floundering for switches, and so on. Therefore, the entire unit is practically left to the Mixer for operation and he has all the switches and patch bays at his fingertips. In operating procedures with the channel, key K_1 permits the mixer to listen to the signal at the recording amplifier buss or to the signal that is actually recorded on the magnetic film. No change in equalization is needed—the Mixer has merely to throw a switch. This is used for all original scoring so that the Mixer himself can be sure that he "has" the take—some jobs not permitting time for a playback. This type of monitoring was not provided in the re-recording operation because of the trouble caused by the time delay. Incidentally, the time delay does not seem to bother the Mixer during direct sound recordings while watching the speaker's lips. It is felt that knowing the take is on the film and in good shape seems to offset the lack of synchronized monitoring. The talkback and monitor amplifiers are used in a conventional fashion but are interlocked by key K_1 , so as to eliminate any possibilities of feedback while using their circuits. Relay K_2 is also used as an interlock to prevent the same difficulty when the microphones are "hot" and a playback is needed on the stage. Key K_3 is used mainly for playing back any original scoring for checking purposes and automatically sends the signal into the linear and flat channel, thence to the playback amplifier and speaker. This is in line with the wanted design in that the Mixer does all the switching involved with the exception of actually rolling the recorders and reproducing equipment. This makes it possible to utilize the services of a relatively inexperienced recordist without having to keep a constant supervising vigil.

A New Development! by WHITE SOUND

GIVES YOU THE
Ultimate in Instrumentation

New! WHITE CABINET SPEAKERS

- A True Exponential Horn . . . (within 1%) Coupled to Speaker through a New Unique Phasing Device and Sound Trap • Nine foot Horn compactly Curled into Non-Resonant Cabinet • Response: 15-18,000 cps • Virtual Distortion Free Reproduction of Low Frequencies • Flowing Peakless Sound without Resonance • Blonde Korina or Mahogany • Hand Rubbed Finish • Bonded Formica Top • Size 35 1/2"H-23W-20D.

Model 3422 FOB \$595.00
White Cabinet Speakers offered in 4 Sizes . . . 3 Finishes . . . 5 Prices.

Ultra High Fidelity . . .

New! WHITE SOUND AMPLIFIERS

- Cross-Coupled Amplifier Circuitry
- Balanced Drive • Tapped Screen Output
- Balanced Impedance Phase Inverter

Exclusive! Non-resonant Cross-Over Circuit • Cross-Over (24db./Octave) at the Input of Dual Channel Amplifier.

For Complete Information, see your Distributor
or Write to Department H-11

105 W. MADISON ST. **WHITE SOUND, INC.** CHICAGO 2, ILLINOIS



Model 3422
15-18,000 cps.



Model 1020

Motor and Signal Circuits

Referring to Fig. 2—the schematic showing the motor and signal circuits—it will be seen that there are four “ready light” positions available—two of which are duplicated in the re-recording room. These positions utilize a holding relay that automatically lights a lamp of the proper color at each of the positions. When the machines start to roll, the power is lifted from the circuit and the lights automatically go out. It was originally thought that—because if a ready light was once put on, the operator could not turn it off if he changed his mind—there might be some trouble. However, this took place only in isolated cases, and then only because of unfamiliarity with the system—a condition encountered occasionally with new or inexperienced personnel. All that is necessary if the operator has to change his signal is for him to use the telephone which is normal between all sound-interested places. When the units start to roll, the ready lights are released and they go out. In case of trouble, the projection rooms have their own selsyn control, used only for stopping. If the machine room has trouble, the operator makes sure the projection lamp is out—by using the telephone—before stopping. For quick emergencies, the talkback microphone can be used. In addition, each selsyn control box has lights showing when it is in a locked position and when rolling so that all interested personnel know exactly what is operating. The “lock” lights are convenient in that they are a signal for the machine men and the projectionist to check their respective motors to make sure that they are in lock and not stalled on a “high spot.” This completely eliminates the possibility of having a runaway machine. The solenoid that disconnects the ready lights is energized by the selsyn control boxes during dubbing and by a separate push button during original voice or music scorings. The same solenoid also energizes the warning light system and automatically rings a three-second bell at the start of recording and sounds a three-second buzzer at the end. These unrelated audible signals have been found sufficient to alert any personnel completely while a “take” is on. Provision is also made to control any a.c. machinery needed by means of the same solenoid relay. A ratchet-type relay was selected so as to draw current only when the contacts are being moved from OFF to ON, or vice versa.

The installation has proved itself time and time again, with very few troubles, to operate in a straightforward and efficient manner in carrying out its sound recording duties, and has come up to the expectations of all concerned.

The author wishes to take this opportunity to thank everyone who has contributed directly or indirectly in the past five years to his film-recording “education.” Particular thanks go to Mr. H. D. Bradbury and his colleagues of RCA Victor Film Recording Division for their helpful advice and assistance.



FREE 236-PAGE ALLIED 1953 ELECTRONIC SUPPLY CATALOG

World's Largest Stocks of Electronic Supplies for Industry and Broadcast Stations

Simplify and speed your purchasing of electronic supplies and equipment—send *all* your orders to ALLIED—the reliable one-supply-source for *all* your electronic needs. Depend on ALLIED for the world's largest stocks of special-purpose electron tubes, test instruments, audio equipment, electronic parts (transformers, capacitors, controls, etc.) and accessories—complete lines of quality apparatus. Our expert industrial supply service saves you time, effort and money. Send today for your **FREE** copy of the 1953 ALLIED Catalog—the *complete, up-to-date* guide to the world's largest stocks of Electronic Supplies for Industrial and Broadcast use.

ONE COMPLETE DEPENDABLE SOURCE FOR EVERYTHING IN ELECTRONICS

We specialize in Electronic Equipment for Research, Development, Maintenance and Production Operation

SEND FOR FREE 1953 CATALOG

ALLIED RADIO CORP.

833 W. Jackson Blvd., Dept. 17-B-3 Chicago 7, Illinois

Custom Styled for Hi-fidelity

by **Cabinart**

MODEL 28
Equipment Cabinet



MODEL 27
Loudspeaker Cabinet

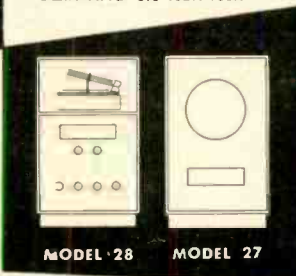

Designed for the audiophile, these handsome cabinets will accommodate any combination of high fidelity components. Panels are replaceable for future changes of equipment. The loudspeaker cabinet is acoustically correct, tuned for the average 12" or 15" loudspeaker, pre-cut as requested. Construction is of select birch, with a fine lacquer finish hand-rubbed to a high gloss. All joints are glued and screwed, and lock-joint miters are used throughout, affording utmost rigidity.

Dimensions:
35½" high, 23½" wide, 18" deep.

Finishes:
Blond Birch
Cordovan Mahogany on Birch.
Baffle Area: 6½ cubic feet.

Net Price
MODEL 27 . . . \$48.00
MODEL 28 . . . \$72.00

Sold through leading radio parts distributors. Write for free catalog and nearest distributor.

G & H WOOD PRODUCTS COMPANY - 75 NORTH 11th STREET - BROOKLYN 11, N. Y.
Pioneers in radio furniture for high fidelity equipment.

Sound Unlimited

Southern California's Finest Audio Headquarters for the
"Famous Modern Classics in Sound" starring the great

Newcomb Classic 25

For UNLIMITED selection of all the stars in sound

Altec • Concertone • Craftsmen • Electro-Voice • Fisher • Fleetwood • Garrard
G.E. • Jensen • Lansing • Magnecord • McIntosh • Newcomb • Pederson
Pickering • Rek-O-Kut • Scott • Stephens • University • Weathers



ZERO IMPEDANCE

(from page 21)

The output transformer should match the loudspeaker to this load. A good compromise for R_1 is 2 to 4 times the magnitude of Z and the time constant $R_1 C_1$ should be approximately 150 micro-seconds.

The value for Z used by the author was low, being around 5,000 ohms; R_1 was 15,000 ohms and C_1 was 0.01 μ f. These values are not critical.

For $R_1 C_1$ time constant of 150 micro-seconds, the reactance of C_1 is equal to R_1 at approximately 1000 cps. Consequently the power loss in the resistor is low below this frequency. In music, very few fundamental tones occur above this frequency which corresponds to two octaves above middle "C" on the piano. Even though some available power is lost at higher frequencies, it is not a serious matter.

In the usual 6V6 class "A" power amplifier, the average screen current and the average plate current both increase when a signal of sinusoidal or symmetrical waveform is applied. If the signal is keyed on and off and a d.c. milliammeter placed in the plate circuit, the meter fluctuates wildly. If instead of maintaining a constant screen voltage, a particular value of screen dropping resistor R_s is chosen, it is possible to minimize this fluctuation in d.c. plate current provided the screen bypass capacitor is removed. The action is simple. In the presence of signal, screen current increases. The resulting increased voltage drop in R_s causes a reduction in screen voltage just sufficient to provide the required compensation. In order to obtain instant action, the screen-bypass capacitor must be removed. The removal of this capacitor results in about 10 per cent reduction in voltage gain, and a loss in screen filtering.

The use of direct-coupled voltage feedback eliminates the need for a large blocking capacitor and ensures proper operation of the feedback circuit at the lowest audio frequencies. The current through the feedback resistor R_{fb} must come through the output transformer, which is a disadvantage. Resistors R_{fb} and R_{fb} should preferably be wire wound.

Positive current feedback is obtained from a portion of the cathode bias resistor R_{cb} of the 6V6, as shown in Fig. 1. R_{cb} is a wire wound potentiometer, and serves as a control to adjust the output impedance. This potentiometer may be replaced by a 200-ohm resistor and the current feedback taken across the full 200 ohms.

The positive feedback control is adjusted in the following manner so that the tube presents zero impedance to its plate load. With the loudspeaker connected, an a.c. voltmeter is connected across the primary of the output transformer with moderate signal applied to the amplifier. A resistor of 5000 to 10,000 ohms (not critical as to value)

and now —

The 2nd Audio Anthology

No bigger, no better than the original Audio Anthology—in fact, it's just the same size and a perfect companion to the most authoritative book you now have on the subject of home music systems. But it contains all new material—reprints of over forty of the valuable articles which have most interested \mathcal{A} 's readers during the past two and a half years.

Features—

- Amplifiers
- Preamplifiers
- Tone Controls
- Phonograph Equipment
- Loudspeakers
- Speaker Enclosures
- Tape Recorder Amplifiers

Customary discounts to distributors.

Board Cover \$3.00 Paper Cover \$2.00

-----CUT OUT-----MAIL TODAY-----

Book Division,
Radio Magazines, Inc.,
P. O. Box 629, Mineola, N. Y.

Sirs: Enclosed is my check money order for copies of the
2nd Audio Anthology.

(Please check one) Board Cover Paper Cover

Name (print carefully)

Address

City Zone State

is then shunted across the transformer primary. The feedback control is adjusted to a point where there is no change in output voltage as this resistor is connected or removed. With full 200 ohms in the feedback control, the output voltage actually increases when the resistor is connected across the transformer, indicating a negative-impedance source. It was found by measurement that the source impedance in the author's amplifier remains zero from 20 to 20,000 cps. It was not checked above this frequency. The drop off below 20 cps is due to the coupling capacitor C_1 .

It should be noted that a blocking capacitor cannot be used in series with the negative feedback resistance R_f . If one were used, the negative feedback would become ineffective at some low frequency, yet the positive feedback would still be effective, and low-frequency oscillation or motorboating is likely to occur.

This circuit has been used by the author for several months, with much enthusiasm. The high frequencies are clear and crisp and piano music is reproduced with excellent clarity. The power output is ample for low-level applications.

R-J SPEAKER

[from page 20]

Construction

The internal construction of the R-J speaker enclosure is shown quite clearly in Fig. 4. All wood used in the construction is $\frac{3}{4}$ -in. plywood, with the external surfaces veneered with suitable hardwood to provide an attractive finish. The dimensions shown will suffice for either 12- or 15-in. speakers, since the speaker size is not critical. The principal requirement is that the free-air cone resonance be relatively low, and the suspension is "soft" enough to provide a high compliance. In the cabinet of Fig. 4, a net internal volume of 4500 cu. in. is provided, exclusive of the internal padding. It will be noted that the speaker board is spaced from the frontal board by such a distance as to reduce the peak caused by the resonance of the enclosure so that the sound output is flat, essentially, from a frequency of 150 cps, let us say, down to 50 cps or less. As previously mentioned, the spacing between the speaker board and the frontal board determines the Q of the enclosure, and effectively eliminates the peak due to the Helmholtz resonator effect.

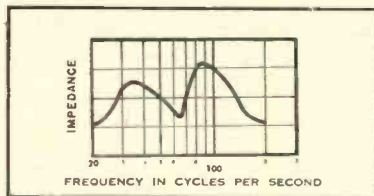

Fig. 5. Impedance curve of the R-J enclosure with the same type of speaker as used in the cabinet of Fig. 1.

Midget
Condenser
Microphone

for
PRECISION
MEASUREMENTS
AND HIGH QUALITY
RECORDING



Built to endure! Gives years of service without change in calibration. Shows no detectable drift in laboratory service, even without dessicators! Proved by use for optimum performance for more than 16 years.

- RUGGED CONSTRUCTION
- EXCEPTIONAL CALIBRATION STABILITY
- UNAFFECTED BY HUMIDITY VARIATIONS

PRINCIPAL CHARACTERISTICS		
	MODEL A	MODEL B
RESPONSE Referred to 1 volt /dyne/cm ²	—59 db	—55 db
FLAT TO WITHIN	±3 db from 20 to 11,000 cps, for closed cavity without grille.	±4 db from 20 to 15,000 cps with or without grille for perpendicular incidence in free field.

Users include government laboratories, universities, audio development laboratories, sound studios and industrial plants manufacturing sound equipment.

SEND FOR FULL SPECIFICATIONS TODAY!
WRITE DEPT. 27A



KELLOGG SWITCHBOARD & SUPPLY COMPANY
79 W. Monroe Street, Chicago 3, Ill.

An Associate of International Telephone and Telegraph Corporation

ATTENTION AUDIO-PHILES

A NEW ACHIEVEMENT IN AM-FM TUNERS

FM-3 Microvolt sensitivity • Pushbutton AFC disabler • Temperature compensated oscillator Foster-Sueley detector • AM-Variable IF bandwidth 5-Microvolt sensitivity • 10 kc whistle filter • 6 position selector switch • separate bass, treble controls • Cathode follower output • Phono pre-amp Flywheel tuning • A striking front panel design.

\$145.20*

*slightly higher in West



THE BOGEN R701



We invite your inspection of our modern sound demonstration room where all the latest components of high fidelity design are available for your comparison. Whether you wish merely an added component or are planning a complete new home system, feel free to write, call, or come in person for competent advice and courteous consideration.

WEST COAST HIGH FIDELITY CENTER
"IN THE AUDIC MILE"

HOLLYWOOD ELECTRONICS

7460 MELROSE AVENUE • LOS ANGELES 46, CALIFORNIA
Webster 3-8208

20-20 PLUS!

S-226-Q Output Transformer

±1 db 10—100,000 cycles
20 watts 30—40,000 cycles

5 watts at 10 cycles
10 watts at 15 cycles

Insertion loss
0.5 db

Primary impedances
6,600 CT & 1,650 CT

Connected between halved impedances, frequency response is extended at each end; between doubled impedances, ±1 db 15—45,000 cycles.



Write today for the new 1953 Peerless Catalog

Dimensions:
4 1/8" x 3 3/8" x 3 3/8"

PEERLESS
Electrical Products

A DIVISION OF **ALTEC**

335E Santa Monica Blvd., Beverly Hills, Calif.
161 Sixth Avenue, New York 13, New York

The opening in the speaker board is the same as the free cone area of the speaker used—10 1/2 in. for a 12-in. speaker and 13 1/2 in. for a 15-in. speaker. The opening in the frontal board was shown to have an area of 64 sq. in.

If the enclosure is to be used as a woofer exclusively, a rectangular slot—as shown in Fig. 4—would be perfectly satisfactory, and adequate performance would be obtained over the frequency range from the lowest transmitted frequency up to 400 or 500 cps. However, if the enclosure is to be used for a wide-range speaker, without the addition of any other speaker or horn for the high range, then the frontal opening must be modified. While the shape of the opening must be determined specifically for each individual cabinet type, it may be described roughly as resembling a "skinny lemon." It may be approximated by laying out a diamond-shaped opening with its major axis about 25 deg. from the vertical—at an azimuth of 025, for the nautical-minded—and with its minor axis at an angle of approximately 15 deg. from the horizontal, or at an azimuth of 295. The minor axis should be one half the length of the major axis, and the total area should be the calculated 64 sq. in. Then, after the diamond shape is laid out, round off the obtuse corners, and extend the acute corners so that the "skinny lemon" shape is attained. From this description, it is obvious that it would be difficult to prescribe the actual opening, but bear in mind that the low-frequency performance is a function of the enclosure volume and the area of the frontal board, and the high-frequency performance is a function of the shape of the frontal opening. The spacing between the speaker board and the frontal board adjusts the Q so as to avoid a peak in sound output throughout the range from 50 to 100 cps.

From the foregoing, it is seen that the low-frequency performance is not as dependent upon the speaker as it is with some other types of housings. It is only important that the free-air cone resonance be relatively low—from 40 to 70 cps. Since the object is to resonate the enclosure somewhat above the cone resonance, and since the volume and the size of the frontal opening determine the resonant frequency, it is readily possible to design a satisfactory cabinet for speakers smaller than the 12- or 15-in. models for which the cabinet of Fig. 4 was calculated. This has been shown by the performance of the 8-in. enclosure, which is 23 1/2 in. long, 11 in. high, and 10 in. deep. The design of this cabinet is the same as for the larger one, being modified only by the differences in size and resonant frequencies.

Comparative Measurements

To show the performance of the system, and to evaluate it in comparison with a conventional bass-reflex box, the equipment shown in Fig. 6 was set up. The amplifier is a modified Williamson employing two 5881's in the output stage, and with 30 db of feedback. The internal output impedance of the amplifier was approximately 0.5 ohms. The



Has Everything to Assure YOUR HI-FI SATISFACTION

- The World's Finest Audio Equipment
- Packaged Systems
- Custom Furniture
- Expert Technical Assistance
- Audio Comparison Sound Studios
- All Standard Makes in Stock at LOWEST PRICES

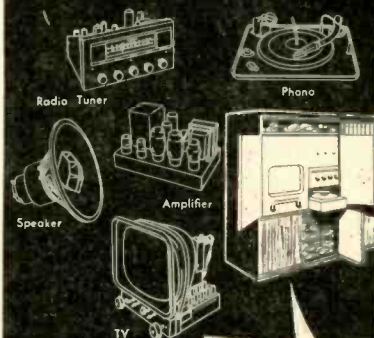

FREE! NEW 1953 HI-FI CATALOG

Complete new buying guide... has everything for the finest reproduction of broadcast and recorded music... ALL Famous High Fidelity Equipment in stock... Radio-Phono and Television Combinations, Record Changers, Recorders, Custom Furniture and Packaged Systems in all price ranges to suit your taste and budget.

Send for Your FREE Copy
Visit Our Sound Studios

HUDSON
RADIO & TELEVISION CORP.

48 WEST 48th ST. • 212 FULTON ST.
New York 36, N. Y. New York 7, N. Y.
Circle 6-4060

Hudson Radio & TV Corp. (Dept. D-1)
48 West 48th St., New York 36, N. Y.

Please send FREE 1953 HI-FI Catalog

Name

Address

City Zone.....State.....

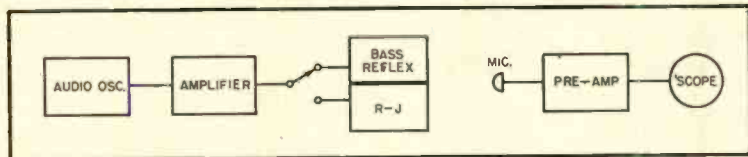

Fig. 6. Block diagram of the test set-up used to compare acoustic outputs of the two types of enclosures.

two enclosures used were the bass-reflex model of Fig. 1 and the R-J of Fig. 4, both being used with a moderately priced 12-in. speaker with an 8-ohm voice coil, and a free-air cone resonance of 63 cps. Both cabinets were placed side by side with the microphone on a horizontal axis through the two cones and in line with the two adjacent sides of the enclosures. The output of the microphone

was fed through a preamplifier to a 5-in. 'scope. The switch permitted feeding the output of the amplifier to either enclosure and the microphone output could then be observed on the 'scope screen. Thus all variables have been eliminated, with the possible exception of differences between the two speakers—although both were identical as to type and manufacturer. Figures 7 through 12

the only personal part of any communication system!

more LISTENING COMFORT with ...

TELEX lightweight headsets!

Modern, lightweight, durable . . . Easily adjustable and built for hard usage, TELEX Headsets give top quality reception without the punishment of extra weight and pressure.

Office Transcribing Machines • Radio Monitoring • Telecasting • Amateur Radio • Record Stores • Theaters • Phone-Order Boards • Wired Music Installations • Commercial Communications • Electronic Laboratories.

Telex produces headsets to manufacturers' specifications



For complete information on any of the above headsets, write

TELEX ELECTRO-ACOUSTIC DIV., Department, G-E St. Paul 1, Minnesota

In Canada ATLAS RADIO CORP., Toronto

*MONOSET
The modern styling and the dependability and superior performance of the TELEX Monoset have made old fashioned headphones obsolete. Magnetic.

*DYNASET
New dynamic under-chin TELEX Dynaset, with more highs and lows of both music and speech, is the delight of radio and TV monitors. Weighs only 1.25 oz.

*TWINSET
This lightweight 1.6 oz. TELEX Twinset pipes signal directly into the ear, blocking out ground noises and banishing listening fatigue. Magnetic.

*EARSET
Sensitive TELEX Earset slips onto ear and is preferred by all who use single-phone headsets. Weighs only 1/2 oz. and leaves other ear free for phone calls or conversation.

Trade Mark Standard of the World for Quality Headsets

TELEX HEARING AT ITS BEST

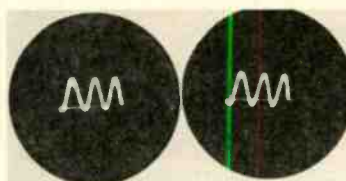

Fig. 7. Acoustic output from the two speakers cabinets as indicated on the 'scope at a frequency of 110 cps. Left, bass reflex; right, R-J.

show the patterns obtained, none of the controls being changed except the main frequency dial of the oscillator and the selector switch. In all of these figures the bass reflex cabinet is shown at the left and the R-J enclosure is shown at the right.

Figure 7 shows approximately the same sound pressure from both cabinets at 110 cps. Figure 8, at 84 cps, corresponds approximately to the cabinet air resonance for both enclosures, as shown by the impedance curves of Figs. 2 and 5. Note the higher output of the bass reflex, resulting in the characteristic "boominess." The R-J output is only slightly increased, and even this could be eliminated by a slight decrease in the spacing between the frontal board and the speaker board.

In Fig. 9, taken at 55 cps, both

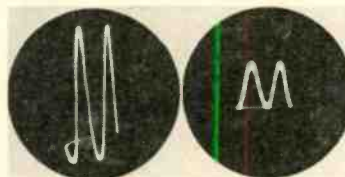
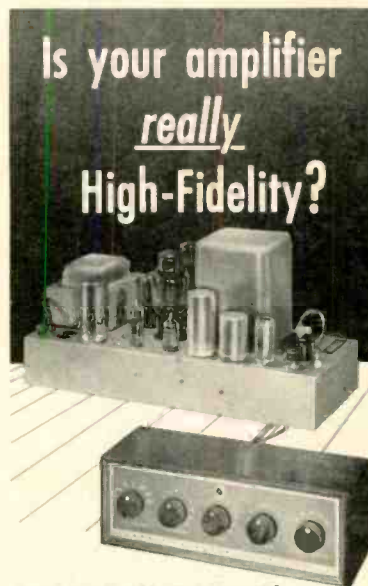

Fig. 8. Acoustic output at 84 cps. Left, bass reflex; right, R-J.

speakers exhibit approximately the same output, but in Fig. 10 at 48 cps, the bass reflex is beginning to exhibit traces of frequency doubling. The R-J is still entirely fundamental. At 44 cps, shown in Fig. 11, the bass reflex has an output which is almost entirely composed of double the frequency of the applied signal—which means almost 100 per cent second harmonic distortion. The difference in pitch is plainly evident upon switching between the two, the bass reflex sounding one octave higher than



ASK FOR ENGINEERING DATA SHEETS ON THE

Stromberg-Carlson

"CUSTOM FOUR HUNDRED" 25-WATT HIGH-FIDELITY AMPLIFIER "AR-425"

This is the amplifier tested and approved by Leopold Stokowski and described by him as incorporating "the latest technical knowledge." Stromberg-Carlson designed it to enable the Audiophile to realize the full capabilities of the finest speakers made—including our own superb 15-inch coaxial speaker! 20-20,000 cps \pm 1/2db. 20 watts at less than 1% total distortion.

BULLETIN SED. 40.70 offers 16 pages of complete engineering data, including tables, charts and curves. Ask your local "Hi-Fi" dealer or write us for a free copy.

NOTE: Amplifier "AR-425" is one of the component parts of the "Custom Four Hundred" line, including a 10-watt Amplifier, and AM-FM Tuner, Changer, 12" or 15" Speaker, Acoustical Labyrinth and TV chassis. Complete cabinet assemblies also available.

STROMBERG-CARLSON
Sound Division

1219 Clifford Ave. Rochester 3, N. Y.

"WHOLESALE RADIO"
For ALL The BEST In
HI-FI

ENJOY HI-FI RECORDING PLEASURE!

Duo-Speed
TAPE RECORDER
PENTRON

Model
9T3C \$134.50



Complete with crystal mike, 600 ft. reel of plastic tape and empty 5" reel. Life-like reproduction. Superlative features and styling. Semi-professional in operation. At the push of a button, provides two full hours recording on a 7" reel (3 3/4" per sec. 50 to 5,000 cycles) one full hour on a 7" reel (7 1/2" per sec. 50 to 8,000 cycles). Has fast forward and rewind speed, 20 to 1, or 70 sec. for 1200 ft. Five watts audio in 6" Alnico V speaker. Additional features include editing key; maple eye recording indicator; crystal mike; mike and radio input jacks; separate record and erase heads. 110 v. AC. Wt.: 27 lbs. A really great portable tape recorder unmatched at this price.

Hi-Fidelity FM Tuners!

BROWNING RV-31 FM TUNER
Complete With Power Supply \$99.50
PILOT FM-AM TUNER
New Design! Self Power Supply 99.50

Hi-Fidelity Amplifiers

GROMMES 50PG, 10 watt audio \$ 55.00
BELL 2122-B, 10 watt audio 50.46
ALTEC A-433A, 15 watts 111.50
ALTEC Pre-amp. A433A 75.00

Hi-Fi Changers & Players

GARRARD 3 spd. changer, RC-80 42.30
REK-O-KUT 12" Turntable, 3 spd. LP743 .. 54.95

Hi-Fidelity Speakers

ALTEC LANSING 12" DUPLEX 601A including
N3000A Network \$ 89.00
ELECTRO-VOICE SP12B \$ 27.00

Hi-Fi GE CARTRIDGES

GE RPX-050 with dual reversible sapphire
stylus, 3 spd. \$ 8.37
GE RPX-051 (Less Stylus), 3 spd. 5.28
GE RPX-052 with combination diamond
and sapphire stylus, 3 spd. 23.37
GE RPX-040 with .003 sapphire 5.97
GE RPX-041 with .001 sapphire 5.97
GE RPX-042 (Less Stylus) 4.25
GE RPX-046 Professional type (less stylus) .. 6.87
GE RPX-047 Broadcast type (less stylus) 3 spd. 9.27

Hi-Fi Audac Reproducers!

3 SPEED! POLYPHASE!
Model LG Head for all lateral records \$20.70
Model LGG For Garrard Changer (Plug-In) .. 23.40
Model LGW For Webster Changer (Plug-In) .. 23.40
All models complete with two genuine sapphire jewels.

FREE! HI-FI CATALOG

Write for free Hi-Fi catalog featuring
newest equipment and advice on high
fidelity systems.

Address Orders To Dept. AE-1

WHOLESALE
RADIO PARTS CO., Inc.
311 W. Baltimore St.
BALTIMORE 1, MD.

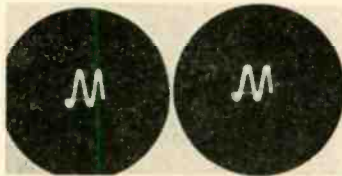

Fig. 9. Acoustic output at 55 cps. Left, bass reflex; right, R-J.

the R-J. Figure 12 shows that the bass reflex is still frequency doubling, while the R-J—although somewhat down in output—still maintains the fundamental tone.

The ability of the R-J system to handle power without frequency doubling at the very low frequencies is due in the main to the air loading on the speaker cone which is the result of the design. This loading is also beneficial in increasing the transient damping of the speaker as well as the power handling capacity. Transient damping which cuts down spurious speaker vibration of

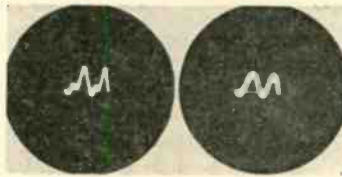

Fig. 10. Acoustic output at 48 cps. Note beginning of frequency doubling in the bass reflex at the left; the R-J is still fundamental.

"hangover" after the signal has ceased may be demonstrated in a simple test. If a small direct current from a battery is keyed on and off, a "click" will be noticed on circuit make, and either a "click" or a "bong" on circuit break, depending on the damping.⁵ It will be noticed particularly with the bass reflex, which exhibits a definite "click-bong" as the circuit is made and broken, while the R-J shows its transient response to be better by responding with a "click-click" for the same treatment.

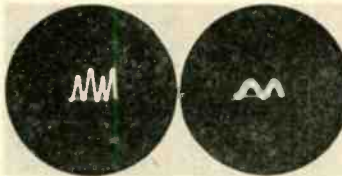

Fig. 11. Acoustic output at 44 cps. Output from bass reflex is seen to be almost 100 per cent harmonic, due to frequency doubling.

Conclusions

From these comparisons, it may be concluded that although it is based on a resonant principle, the R-J enclosure is a non-resonant system. The response with a 12-in. cone having a free-air resonance of 63 cps is smooth down to 50 cps, and has usable but attenuated output down to 30 cps. It is also shown

⁵ Benjamin B. Drisko, "Getting the most out of a reflex-type speaker." *AUDIO ENGINEERING*, July 1948.

GENERAL HI-FI
SPEAKER SYSTEMS

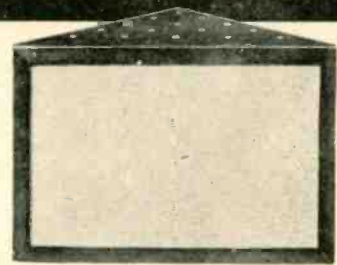

Here's the famous Baruch-Lang complete speaker system at a new low price. Contains four special 5" speakers in acoustically designed corner cabinet 13" high, 19" wide, 9 3/4" deep. Available finished in Mahogany, Blond or Black, or unfinished, less frame and grille cloth as a basic speaker for P.A. applications. Impedance 4 ohms, may be rewired for 16 ohms. With 15 ft. plastic cord terminating in 2 alligator clips. Shpg. wt. 12 lbs.

GENERAL HI-FI SPEAKER SYSTEMS

Unfinished Net 24⁹⁵
Finished (Specify Color).....Net 29⁹⁵

ARROW ELECTRONICS'

AudioCenter
BEAUTY IN SOUND

65 CORTLAND ST., NEW YORK 7, N. Y., DIGBY 9-4714

GROMMES
AMPLIFIERS



Model 50 PG

A high fidelity single unit amplifier with unusual performance. Power output, 10 watts, 0 watts peak. Distortion at 10 watts, 1% harmonic and 2% intermodulation. Frequency response: ± 1 db, 30 to 20,000 cps. (± 1 db, 50 to 20,000 cps at 10 watt level). \$55⁰⁰



Model LJ2

Power output, 6 watts, 12 watts peak. Distortion at 6 watts, 1 1/2% harmonic and 4% intermodulation. Frequency response: ± 1 db, 20 to 20,000 cps. (± 1 db, 50 to 20,000 cps at 3 watt level). \$36⁵⁰

WRITE FOR CATALOG

PRECISION ELECTRONICS, Inc.
9101 King Avenue, Franklin Park, Ill.

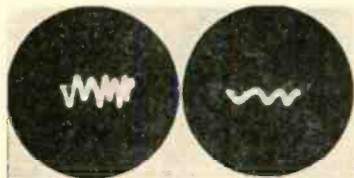

Fig. 12. Acoustic output at 32 cps. Although slightly lower in output, the R-J—at the right—is still fundamental in character.

that the R-J provides air loading which is instrumental in preventing frequency doubling and tripling, and maintains fundamental tones with a 12-in. speaker down to 30 cps. In addition, the R-J offers excellent speaker damping with the result that transient response is maintained.

BINAURAL RADIO

(from page 14)

response than AM assure positive support from this second channel.

Those who want binaural reception must own an FM receiver—which means an increase in sales and production of FM or AM-FM sets. This is a step in the right direction to help establish a more solid commercial value for the FM station. This is a very real need, because of receiver manufacturers' cutting back or stopping production of complete package units. If this transition to binaural reception can grow rapidly enough, it may increase the number of FM set owners, and many of them will become converted to the FM monaural stations. Enough of such activities might prevent some FM station failures.

During the transition from monaural broadcasting to various new levels of binaural programming, many listeners will find that the advantages of listening to two radios will broaden the area of sound reproduction, getting away from the single-spot source of sound. One-receiver listening eventually will swing back to FM, which again will build up the value of the FM service.

The FM and the AM reception is in no way reduced in efficiency by using one receiver monaurally, while the value for both services is increased to the listener when used together for binaural reception. The power consumed at the two transmitters costs the same regardless of the studio pickup technique—monaural or binaural. However at the listening end the two receivers, when tuned to two stations transmitting binaurally, will produce more usable listening volume, allowing the volume controls on each receiver to be set much lower than required for monaural listening. This is a gain in efficiency yet to be accurately evaluated, but it definitely exists.

At Troy, New York, Rensselaer Polytechnic Institute operates stations WHAZ and WRPI for experimental and public service programs. Both of these stations use AM, one on 1330 kc and the other on 640 kc. Listeners in this area are now enjoying binaural programs with two AM receivers tuned to the two frequencies. This method of binaural broadcasting is permissible under FCC regulations when the station which originates the program, either live or recorded, gives permission in writing to another station for simultaneous or delayed broadcasting. Co-operation between two AM or two FM stations in a territory

OUTPERFORMS ORDINARY ENCLOSURES
MORE THAN 3 TIMES ITS SIZE!

New

MAXIMUM BASS
MINIMUM SPACE!

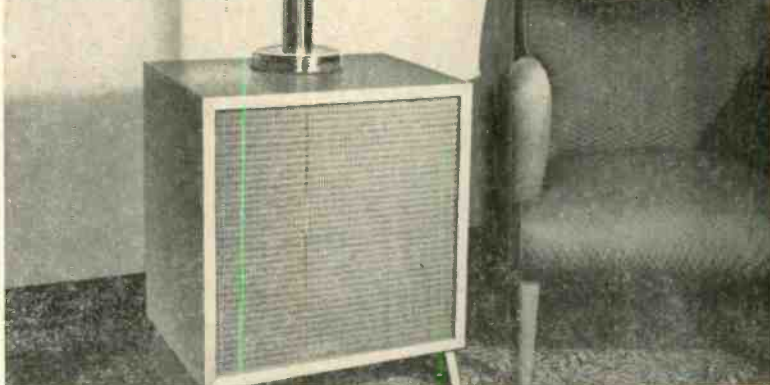

USE WITH ANY LOUDSPEAKER FOR FINEST PERFORMANCE

A new trend! R-J enclosures will amaze you, as they did thousands at the Audio Fairs! Three models, each only slightly larger than the 8", 12" or 15" speaker it fits. Yet, you'll hear clean, smooth bass fundamentals, down to low organ pedal notes. Clean, unobstructed "highs", too. No distorting cabinet resonances. Versatile, low in price... especially adaptable to normal-size rooms. Mahogany or blonde Korina, fine furniture construction. Available for first time, at leading sound departments.

Send coupon for literature

Visit The Los Angeles Audio Fair, February 5th, 6th, 7th
Hotel Alexandria, Rooms 615 and 618

R-J Audio Products
164 Duane Street, N. Y. 13, Dept. AE-1
Gentlemen:
Please send literature and information on
R-J Speaker Enclosures.
Name.....
Address.....
City.....State.....

The Right Combination

DIACOUSTIC

DEPENDABLE

DIAMONDS*

for

RCA • WE • GE and other Reproducers

STANDARD OR MICROGROOVE

Diacoustic Resharpener Service for

§SAPPHIRE CUTTING STYLII

Guaranteed Under Capps Patents

LITERATURE AND PRICES ON REQUEST

Diacoustic Laboratory

P. O. Box "P" Phone STate 4-0881

Encino, California

§Synthetic

*Genuine

A S NEW!
C



**SONOCRAFT
FM TUNER
\$89.95**

Modern design throughout. Compact size (only 4½" high x 10" wide) permits use as a replacement in almost any type of music system, bringing it up to present day standards.

DESIGN FEATURES

- Novel blackout tuning indicator in VTVM circuit
- Drift free—Automatic Frequency Control
- 5 Microvolts sensitivity
- AFC can be disabled in strong signal areas
- Full Armstrong circuit—completely shielded
- Exclusive design of dial plate provides for simple cabinet installation

NOW OPEN A new studio designed for you—right in the heart of New York City. America's finest and most flexible sound demonstration studio—At last you may experience the breathtaking realism of reproduced music.

FREE
WRITTEN FOR
MUSIC LOVERS
BY
IRVING GREENE

124 pages — chock full of valuable information and listings of high fidelity components. Dept. EA

**ALLIED SOUND
CORPORATION**

115 WEST 45 STREET (3rd FLOOR)
NEXT TO TIMES SQUARE
NEW YORK 36, N. Y. LUXemburg 2-1750

served by both could be the means of binaural broadcasts. As good-will builders and long-range public relation service it has great value.

In television and movies, another handicap is added to nature's facilities by using a single-lens sight pickup on the camera. These two handicaps add to a condition where both sight and hearing are fatigued more rapidly than in nature where two ears and eyes are used normally, as at the opera, stage, or concert.

Binaural radio sound reproduction provides nature's two-ear listening facility and when stereo television with binaural sound becomes available fatigue will be greatly reduced. Many observers agree that (two ear) binaural radio broadcasts will fatigue us less rapidly and keep us alert to the program—including the sponsor's message—for a longer period. This may help the sponsor make a deeper impression on the listener against the chatter of those assembled at home to hear a favorite program, even though these listeners are using it for atmosphere background.

Activities in 1952

In late October 1952 binaural broadcasting in New York was introduced at the Audio Fair, and its impact is still being felt. Station KOMO in Seattle in the same month did a successful broadcast which struck a high level of local appreciation.

Station WJR in Detroit used its AM-FM stations to produce two binaural broadcasts each week for eight weeks during July and August. These broadcasts were enthusiastically received by hundreds of hi-fi fans with their wider range AM-FM combinations, and a big audience of listeners using package AM and FM receivers. These concerts featured the Detroit Symphony Pops Orchestra under the direction of Ed Werner at the Jefferson Beach open-air music center. Detroit newspapers carried a continuous one-column cut showing a diagram for a receiver setup at home. Spot announcements daily kept the audience growing. Future plans are soon to be announced.

Station WQXR in New York agreed early in September to program an AM-FM broadcast for the banquet entertainment at the Fourth Annual Convention of the Audio Engineering Society on October 30. This finally resolved in two binaural broadcasts sponsored by Magnecord, Inc. on October 29 and 30. The October 29 broadcast used a binaural Magnecorder and a completely taped show. The program on October 30 was produced by WQXR's musical staff with a live 28-piece symphonic ensemble and two voices. In the ballroom of Hotel New Yorker, the banquet guests listened to the radio reproduction from Electro-Voice Patrician speakers fed by Fisher Radio Corporation tuners and amplifiers. Norman Brokenshire, well-known announcer, gave his hearty approval from the studio where he was listening "off-the-air" to two RCA table model receivers. This program was the first known binaural network broadcast, as it was relayed by FM radio to WDRC-FM on Mount Meriden in Connecticut, and the AM was piped by telephone line to WDRC studios in Hartford, Connecticut.

Both WQXR and WDRC were swamped with phone calls from a large audience, and requests for more binaural broadcasts followed by mail. These requests were fulfilled on November 9 when the Harvey Radio Company of New York started a 52-week series of one-hour binaural broadcasts in co-sponsorship with Magnecord, Inc. The program is the regular WQXR

for every application...

ATLAS MIKE STANDS
most complete—
most diversified
line in the world

From a professional boom stand to a flexible goose neck to a tiny fitting—whatever your need in mike stands and accessories—depend on it, ATLAS has it for you. Designed and manufactured for highest stability, quiet, ease of operation, durability. And backed up 100% by ATLAS—world leader in mike stands, public address loudspeakers and accessories for 21 years. Compare them all at your distributor—You'll make your next mike stand an ATLAS.

ATLAS SOUND CORP.
1448-39th Street, Brooklyn 18, New York
In Canada, Atlas Radio Corp., Ltd., Toronto, Ont.

**THE AUDIO FAIR is for you
The Hi Fi Audiophile!**

The **Concertone** was designed for you and incorporates the following modern developments at no extra cost.

- High speed forward and rewind
- Simultaneous monitoring from tape
- Use of professional reels
- Built-in equalization and speed change

It is the acme of Hi Fi performance



See and compare before you buy. We will gladly demonstrate it in our auditorium. We carry a complete line of Hi Fi equipment.

Magnetic Reorders Company
7120 MELROSE AVENUE
LOS ANGELES 46, CALIF.
Telephone WEbster 3-5545

String Quartet from 6 to 7 p. m. each Sunday. This show is well produced and the effect is thoroughly realistic.

Beginning January 3, WQXR will present each Saturday from 4:30 to 5:00 p. m. through January, February, March, and April, a series of organ recitals by outstanding members of the American Guild of Organists. These programs will originate from Temple Emmanu-El under the direction of Dr. Hugh Giles, Chairman of the Guild and organist at Central Presbyterian Church in New York.

WDRC in Hartford is revamping one of its studios (20' x 28' x 16') for binaural programming. WDRC is owned and operated by F. M. Doolittle, mentioned earlier as the daddy of binaural broadcasting.

WNYC, New York City's municipal station, arranged to have Mayor Impelleri give his Christmas Day message binaurally. It is also planned to broadcast an intensive binaural series from February 12 to 22 with the entire annual American Music Festival, including the United States Army Band and the New York Philharmonic Orchestra directly from Carnegie Hall. As a series, these binaural broadcasts will be the most pretentious yet to be performed, and should go far to establish binaural radio programming.

Station WGAR in Cleveland has recently done a series of nightly 15-minute programs of binaural tape with encouraging audience reaction. One listener said his dog ran back and forth from one radio to the other to catch the ping-pong ball reproduced binaurally during the program. Intensive plans are under way for both live symphony and tape shows to satisfy a big audience.

Station WCAE in Pittsburgh produced a series of successful binaural broadcasts in November, using tape and live orchestra. The station plans to do a great deal with binaural programming in 1953.

These brief comments about binaural broadcasts and plans for the stations mentioned were picked up in telephone conversations with program personnel at each station early in December. The personal enthusiasm of each individual reflects the spirit necessary to bring healthy changes into broadcasting. This article was not intended to be technical. For those interested, reference should be made to the excellent article "Stereophonic Sound Reproduction" by James Moir of England, which appeared in the September issue of *Æ*.



Jack Seligman

"We're the repair men for your binaural sound system."

REVERBERATION UNIT

Now made EXCLUSIVELY in improved form
by AUDIO INSTRUMENT CO., INC.

Simulates reverberation of a room of any size, using a magnetic tape loop system with FIVE heads. Switching heads produces various special effects, as well as natural reverberation.

MODEL 40

Compact: single 8 3/4" x 19" panel
Levels: Input,—30 dbm or +4 dbm at 600 ohms
Output,—30 dbm or +4 dbm at 600 ohms
Controlled by switch on chassis

Variable equalization: Built in, for special effects
Reverberation time: Up to ten seconds, continuously variable
Delivery: Six weeks



NOW AVAILABLE The GRAMPIAN Feedback Disk Recording Cutterhead Unit

Engineers and musicians now realize a perfect transient response of any recording system is of paramount importance—the Grampian cutterhead with its precision-made true balanced armature and flux correcting feedback loop obtains this ideal. Used by international broadcast networks where fidelity is of primary importance, you too, can be assured of the highest fidelity disk recording.

Many outstanding recordings, such as the LP Mercury Olympian Series, were recently produced with the Grampian.

For more information, write to

Wide frequency range
30 c/s to 20 kc
Low Distortion
Superior transient response



REEVES EQUIPMENT CORP.
10 EAST 52nd STREET • NEW YORK 22, N. Y., U. S. A.
CABLE: REEVESQUIP, N. Y.

protect your SOUND INSTALLATION profits!

use

LOWELL



speaker housings
and baffles

• Lowell's "complete package" gives speaker POSITIVE PROTECTION from dust, mortar . . . cuts installation time . . . assures beautiful job! Baffles have "floating conical action" to give clear, distortion-free, low level sound diffusion!

- Lowell 22 gauge steel back cover speaker can (spot welded to 22 gauge steel plaster ring) protects recessed speakers in new or remodeling installations.
- Sectional view of completed assembly using AL Series flush mounting low ceiling baffle. AL Series baffle for 6" to 15" speakers.
- BL Series surface mounting baffle for normal height ceilings; for 6" to 12" speakers.

Write for complete catalog and prices.

LOWELL MANUFACTURING COMPANY

3030 Laclede Station Rd., St. Louis, Missouri

In Canada: Atlas Radio Corp., 560 King St., West, Toronto, Ontario

ADCOLA

REGISTERED TRADE MARK

SOLDERING INSTRUMENTS

Any Voltage Range Supplied from 6/7 to 230/250 volts. Our instruments for 110 volts are superb in making

SOUND JOINTS for all SOUND EQUIPMENT

Supplied to leading British electrical manufacturers and H.M. and foreign government departments.

These soldering instruments are named instruments as they are such a complete departure in design from the usual solder bolt or iron and are ideal for all modern assembly and maintenance work on telecommunication, radar, television, wireless, etc.

3/16" dia. bit Standard Models
3/16" Detachable Bit Type (Factory Bench Line)

- Heating time: 90 seconds
- Consumption: 25 watts
- Weight: 4 ozs.
- High temperature
- Handle unaffected by element temperature
- Length of instrument: 9"
- Equally suitable for daily or intermittent use
- Prices ex Works.
Standard 3/16" Bit Model \$3.60
Standard 1/4" Bit Model 4.00
Detachable 3/16" Bit Model 4.80

Catalogue sent free on request.

MADE IN ENGLAND

Registered Design (U.S.A., British, & Foreign Patents)

Write direct to sole manufacturers and suppliers:

ADCOLA PRODUCTS, LTD.
CRANMER COURT
CLAPHAM HIGH STREET
LONDON, S.W. 4, ENGLAND

Standard Model 3/16" Bit Illustrated



AUDIO TRANSFORMER

[from page 44]

represents 2 db, and 99 per cent represents 0.23 db.

The use of the charts in *Figs. 5 and 6* to determine efficiency is illustrated by *Fig. 7*. *Figure 5* is used to find the maximum efficiency of which a transformer is capable, and the relation between the actual operating impedance of the transformer and that producing this maximum. *Figure 6* then gives the actual efficiency from this information. r_w is the total winding resistance referred to the winding chosen for making the calculation; R_p is the shunt loss due to the core, referred to the same winding, and measured at a mid-frequency of, say 1000 cps. (Although somewhat lower frequencies are often taken for mid-frequency for other audio purposes, 1000 cps gives a fairer picture for audio transformer efficiency). An impedance which is the geometric mean of r_w and R_p results in maximum efficiency, and this maximum efficiency is given by the η scale on *Fig. 5*. At the same time, reference in the manner shown in *Fig. 7* gives a value of Z_{opt}/Z , indicating by what ratio the actual impedance, Z , at which the reference winding is operating, differs from Z_{opt} , which gives this maximum efficiency.

The maximum efficiency point is not always the best impedance at which to work a transformer, because frequency response must be considered as well, and in smaller models harmonic generation may also affect the consideration.

Having found what the efficiency is for one particular impedance, the construction of the charts avoids the necessity for going through the whole procedure again for another impedance; the efficiency for the new impedance may simply be read off from a different point on the same curve of *Fig. 6*.

Harmonic Generation

This is a relatively simple calculation, so no special chart has been provided for it. The previous article gave a method of measuring harmonic content as a percentage of fundamental magnetizing current. Magnetizing current at the frequency and amplitude concerned can be expressed as a shunt impedance referred to the primary. The source impedance and load impedance referred to the primary can also be expressed as a combined shunt impedance. To find the effective harmonic percentage generated, the percentage measured is then divided by the ratio between the shunt impedance due to magnetizing current and that due to external circuit impedances. For example, if the measured percentage is 15 per cent, the shunt impedance due to magnetizing current 50,000 ohms, the plate resistance 20,000 ohms, and the referred load resistance 5000 ohms: the external shunt impedance is 4000 ohms, and the effective

Concertone maintains its leadership through constant achievement

Concertone's leadership in the field of high fidelity recording is maintained by constantly improving the quality of Concertone magnetic tape recorders.

Concertone engineers continually incorporate advancements into the design—thereby keeping consistently ahead of the field. Concertone recorders never become "dated" or outmoded. Now, more than ever before, Concertone is truly the standard of high fidelity performance.

Professional users' net prices begin at \$345.00. Write for literature.



Network Recorder NWR-1



Manufactured by

Berlant Associates

4917 W. Jefferson Blvd., Los Angeles 16, Calif.

Yours... FREE!



TERMINAL'S
New, Illustrated, 130-page

AUDIO CATALOG

Your complete guide to the Finest in Audio Equipment!

Write or come in for your FREE Complimentary Copy!

Visit our Audio Dept.
Open Thurs. eves. till 9 P.M.
Ample Parking Space after 6 P.M.

Terminal Radio Corp.
85 Cortlandt St., New York 7

Why use Microwaves?

Read ESSENTIALS OF MICROWAVES

By Robert B. Muchmore, Hughes Aircraft Co. An expert's practical survey of the physical principles of microwaves and applications of microwave equipment. Word pictures replace complicated mathematics. 1952. 236 pages. \$4.50.

JOHN WILEY & SONS, INC.
440-4th Avenue New York 16
Write for a copy on 10 day approval.

harmonic generation, $\frac{15 \times 4}{50} = 1.2$ per cent.

Input Transformers

Insertion loss in an input transformer is usually unimportant compared with its frequency characteristic and other properties. It is normally direct coupled, but with no d.c. polarizing. Due to low signal levels, working flux densities in the core are extremely small, and the effective primary inductance varies over a considerable range with variation of signal level. Inductance should be sufficient to maintain good response, even with its smallest value. If it is not sufficient to do this, the only remedy is to reduce the working impedance by additional shunt resistance, which will also add insertion loss—at a point it can ill be afforded; so generally a compromise is necessary, or a better transformer.

Its h.f. response is generally determined as to range by the impedance to which the source is matched by its step-up, and the input capacitance of the tube it feeds. Sometimes an h.f. peak appears, as will be shown by use of Fig. 1. In such cases increase in input capacitance pulls down the frequency of peak, but usually increases its height; the best remedy is an appropriate value of shunt R across the secondary. If this restricts the range more than is desired, tube input capacitance must be reduced as well, by the use of a little inverse current feedback (leaving off the cathode by-pass capacitor). The only alternative is another transformer with less step-up.

If the whole chain has a deficiency in highs that can be corrected by peaking, the input transformer is a good place to introduce such correction, because it will boost the highs in the signal before the thermal noise of the first stage is added to it.

Shielding against hum pick-up is not one of the properties within the scope of this article, but it is important for some input transformers, and so should be mentioned. Some reduction can always be effected by orientation, but if shielding is totally inadequate the only answer is a better shielded job.

Interstage Transformers

Direct-coupled types carrying d.c. polarizing usually have larger leakage inductance and self-capacitance than types without provision for d.c. polarizing. If low frequencies are deficient, the best remedy is to shunt the primary with a suitable resistor. This will bypass some of the polarizing current, thereby increasing inductance slightly, and at the same time reduce effective source impedance. But this shunt resistance may produce a peaking effect in the h.f. response. As with input transformers, this may be overcome by suitable shunt resistance across the secondary. The charts can be used to find the best combination more readily than protracted trial and error, taking a frequency run each time a change is made.

Authentic
“WILLIAMSON”

HIGH FIDELITY
off the shelf!

Point one feature of the Partridge-Williamson WWFB Audio Transformer—you are assured from the word ‘go’ of the performance exactly as intended by the designer. Point two—you can get that performance “off the shelf” from any good radio jobber—for the WWFB is now available to all—there is now no need to suffer anything less than the best—remember there just is no substitute for the Partridge-Williamson (vide “Audio Engineering”, Nov 1949). Your assurance is in the fact that no WWFB leaves our works without being individually tested to make sure it lives ‘up to specification’.

If in difficulty, don't hesitate, write us direct giving your jobbers address—we will see that you are supplied without delay.

PRICE
\$26.00
duty paid

PARTRIDGE-WILLIAMSON *of course!*

PARTRIDGE TRANSFORMERS LTD., TOLWORTH, SURREY, ENGLAND

35 POUNDS OF STUDIO QUALITY

-on remotes PORTABLE AMPLIFIER

- AC OR BATTERY OPERATION banishes power failure problems.
- ELIMINATES ANNOYING HISS, hum and microphonics.
- “WOOFING” NO LONGER NECESSARY. Unit includes a 400-cycle tone oscillator. An original G-E development.

PLUS low level output with volume control, shock mounting, test tone, and high gain cue circuit for noisy locations.

SEND FOR FREE BULLETIN
General Electric Co., Sec. 4413
Electronics Park, Syracuse, N. Y.



GENERAL  ELECTRIC

**SAVE
33 1/3%**



This is our
GROUP SUBSCRIPTION PLAN

You and your friends and co-workers can now save up to \$1.00 on each subscription to **AUDIO ENGINEERING**. The more men in a Group, the more each saves. If you send 6 or more subscriptions for the U.S.A. and Canada, they will cost each subscriber \$2.00, 1/3 less than the price of a regular 1-year subscription. **Present subscriptions may be renewed or extended as part of a Group.**

AUDIO ENGINEERING is still

- The only publication devoted entirely to Audio—
- Recording
- Broadcasting equipment
- Acoustics
- Home reproduction systems
- PA systems
- Psychoacoustics

(Please print)

Name
Address
Position Company

Name
Address
Position Company

Name
Address
Position Company

Name
Address
Position Company

Name
Address
Position Company

Name
Address
Position Company

Add \$.50 to each Foreign subscription ordered

RADIO MAGAZINES, INC.
P. O. Box 629, Mineola, N. Y.

Parallel-fed types of interstage transformer may cause peaking at one or both ends of the audio spectrum. In general it is best to avoid peaking at the l.f. end, aiming at a value of L/CrR greater than unity, so that variation of inductance with level produces a minimum variation in response. However, going too far in this direction may restrict the l.f. range more than is desired; so the charts may be used to find the best compromise, using two different values of inductance (extremes of variation with level) to see what effect signal level can have on response.

The h.f. end will be easier to handle, because with most parallel-fed components there is more in hand. The limit to step-up is generally set in the same way as for input transformers.

Some points should be noted here that help in getting just the right effect at both ends of the spectrum at once. Resistance across the secondary has the effect of reducing tendency to peak at both ends, although maybe in different degrees, according to relative values of L/CrR for each end. Varying the coupling resistor also has a similar effect at both ends, but possibly different in degree. Usually if the secondary shunt resistor has more effect at one end, the value of coupling resistor will have more effect at the other. But a resistor in shunt with the primary (after the coupling capacitor), has opposite effects at each end: at the l.f. end it is the same as an equivalent referred value shunted across the secondary, and so reduces the tendency to peak; but at the h.f. end it shunts the source resistance, reducing the value of r , so increasing the tendency to peak.

Thus adjustments of coupling resistor, coupling capacitor, shunt primary resistor, and shunt secondary resistor, afford a considerable variety of possibilities with the parallel-fed type of interstage transformer. Exploration of these possibilities to find the best combination can be greatly expedited by use of the charts.

Output Transformers

In output transformers everything takes on different proportions. The transformer is step-down, and most circuits—even using tetrode or pentode outputs (inverse voltage feedback being invariably used)—have an effective plate resistance that is but a fraction of the referred load resistance; so peaking at h.f. is impossible. Instead, harmonic generation and efficiency are now the features to watch. If harmonic generation at the lowest frequency of interest is kept low, l.f. response also will usually be taken care of. The charts in *Figs. 5* and *6* will be useful in working out efficiency, particularly to determine whether a transformer designed for operation between, say, 7000 and 5 ohms, will serve satisfactorily between 10,000 and 7 ohms, or between 5000 and 3 1/2 ohms.

The remarks here made about output transformers also apply to loudspeaker and line-matching transformers.

CLASSIFIED

Rates: 10¢ per word per insertion for noncommercial advertisements; 25¢ per word for commercial advertisements. Rates are net, and no discounts will be allowed. Copy must be accompanied by remittance in full, and must reach the New York office by the first of the month preceding the date of issue.

THE AUDIO EXCHANGE, INC. buys and sells quality high-fidelity sound systems and components. Guaranteed used and new equipment. Catalogue, Dept. \mathcal{A} , 159-19 Hillside Ave., Jamaica 32, N. Y. Telephone OL 8-0445.

PRESTO 16-in. RECORDER, Model "Y." Complete with two channel inputs, two speeds—33 1/3 and 78, hi-fi amplifier, and cutting head. Good condition. Best offer over \$300. W. A. Karr, 6033 Woodlawn, Chicago 37, Ill.

CUSTOM Ultra-Linear Williamson Amplifiers, \$89.50. Send for photos and facts. Dr. Nicely, Kenton, Ohio.

SOUND LEVEL METER, Western Electric Model 700A. Perfect condition. \$250. Box 4554, Jacksonville, Florida.

WANTED—Used Semi-professional tape recorder, Twin-Trax or similar. Yalcin, 822 Hanshaw Road, Ithaca, N. Y.

FOR SALE: McIntosh 20-W-2 with AE-2A, \$175, by check or money order. Raymond, 17 Oak Park, Tacoma 9, Washington.

DISC-RECORDING SERVICE

Top-quality discs cut from your tapes or records. All sizes, all speeds. Twenty-four hour service for small quantities. Price for 10-in. LP record, \$2.25.

UNIFA, INC.
80-08 135th St., Kew Gardens, N. Y.
Liggett 4-1203

WESTERN ELECTRIC KS-12025 horn, with or without WE Hi-Fi surplus driver and 800-cps crossover. Telephone Brooklyn (N. Y.) SH 8-4546.

AMPLIFIERS FOR SALE: Altec A-323, like new, \$50; Stromberg-Carlson, 10-watt, new, \$50; Amplifier Corp. of America ACA-1000, new, \$100; Scott amplifier with noise suppressor, \$150; Presto disc recorder, Model K, like new, \$180. H. Unfried, 33 Westfield Rd., Buffalo 21, N. Y.

FOR SALE: 30 rolls (800 ft.) single perforated Scotch Brand magnetic 16-mm film, No. 116—new: University of Minnesota, Purchasing Department, Minneapolis 14, Minn.

STEPHENS P15 in perfect condition, \$25. David Fonseca, 555 Notre Dame Ave., Chattanooga, Tenn.

FOR SALE: H. H. Scott type 410 Sound Level Meter complete with leather case. Like new, complete with batteries, instruction book. Bargain, only \$150. Box CJ-1, **AUDIO ENGINEERING.**

NEW G.E. Variable-Reluctance "twist" dual phono cartridges, \$5.95 ea. Send for list on all other high-fidelity equipment and components at great savings. High-Fidelity Guild, Box CJ-2, **AUDIO ENGINEERING.**

FOR SALE: Tuners—Craftsmen C10 \$95; Browning RJ-20, \$70. Amplifiers—Craftsmen C500, \$80; Masco MA-10HF, \$25. Speaker—Electro-Voice SP12B, \$18. Ralph Ashworth, Charlton City, Mass.

LEADING WEST COAST AUDIO REPRESENTATIVES

The representatives listed below are for the use of dealers and distributors only. The Hobbists and Experimenters are requested to contact their dealer for information.

OXFORD SPEAKERS

Chicago Transformers

Rauland-Borg Sound Systems

J. T. Hill Sales Co.

800 W. 11th St., Los Angeles 15, Calif.

DuBois — British Tri-Sol Solder; Duotone — needles, blanks, tape; Johnson—Sockets, Jacks, Pilot lights, Knobs; Racon — Public Address Speakers; Radio Receptor—Rectifiers; Speak-o-phone—Tape Recorders; Trimm—Headphones.

Don C. Wallace & William H. Wallace
1206 Maple Av. L. A. 15—RI 70401

COLLARO Record Changers
FAIRCHILD Disc and Tape Equipment
TECH LABS Reverberation Generators

KITTLESON COMPANY

Telephone Whitney 1167
7614 Melrose Ave., Los Angeles 46, Calif.



Tape Recorders and Accessories

Acoustone Hi Fi Grill Cloth

Utah Loudspeakers & Baffles

Telephone: Underhill 0-3594

GEORGE DAVIS SALES CO.

5259 E. Beverly Blvd., Los Angeles 22, Calif.

GARRARD RECORD CHANGERS

motors, bases, etc.
R-J SPEAKER ENCLOSURES
BRITISH INDUSTRIES PRODUCTS
Leak, Wharfedale, etc.

ASTATIC MICROPHONES,

Pickups, Cartridges, TV Boosters
CLETRON SPEAKERS,
with Aluminum Voice Coil forms.

BELL SOUND SYSTEMS:

Three-speed Tape Recorders,
Amplifiers, Inter-coms etc.

HARRY A. LASURE COMPANY

9041 West Pico Blvd., Los Angeles 35, Calif.
CRestview 6-4185 BRadshaw 2-7307

CARL A. STONE ASSOCIATES, INC.

1102 S. Western Ave. 420 Market Street
Los Angeles 6, Cal. San Francisco 11, Cal.
Republic 2-8103 Exbrook 2-4009

We Invite You To Hear

H. H. Scott Inc. 214-A Amplifier
Browning Lab. Inc. RV 31 FM Tuner
Room 649

Henry Feldman Company

• PRESTO Recording Corp.

• STEPHENS SPEAKERS

• ECTRO "Cub-Corder"

• Audio Instrument Co. Inc.

LEE OWENS

2331 W. Washington Blvd., Los Angeles 18

MARSHANK SALES CO.

672 So. Lafayette Park Place
Los Angeles 5, California
Phone Dunkirk 7-8235
REPRESENTING

Bogen - University - Hallicrafters - Turner

Audio Components

Douglas H. Loukota Co.

Cleveland 6-2286
6137 York Blvd. Los Angeles 46, Calif.

**PERLMUTH-COLMAN
and ASSOCIATES**

1335 So. Flower St.
Los Angeles 15, Calif.

OUR 30th YEAR

representing
AUDIO and SOUND Mfgs.
in
California, Arizona, Nevada
Travelling 8 Salesmen

**PERLMUTH-COLMAN
and ASSOCIATES**

1335 So. Flower, Los Angeles 15, Calif.

NEELY ENTERPRISES

REPRESENTATIVES FOR AMERICA'S
FINEST SOUND REPRODUCING EQUIPMENT
IN CALIFORNIA, NEW MEXICO, ARIZONA, NEVADA

Magnecord
TAPE RECORDERS

McIntosh
AMPLIFIERS

American
MICROPHONES

Jim Lansing
SIGNATURE SPEAKERS

WEATHERS

FM PICKUPS

MARKEL

RECORD CHANGERS

TELEFUNKEN

Products

NEELY ENTERPRISES

Los Angeles
7422 Melrose Avenue
Los Angeles 46, Calif.

San Francisco
2830 Geary Boulevard
San Francisco 18, Calif.

Sacramento
1317 Fifteenth Street
Sacramento 14, Calif.
Phone: Gilbert 2-8901

San Diego
1029 Rosecrans Street
San Diego 6, Calif.

Albuquerque
107 Washington St., S.E.
Albuquerque, N. M.

Phoenix
32 West Jefferson St.
Phoenix, Arizona

DO YOU HAVE YOURS?

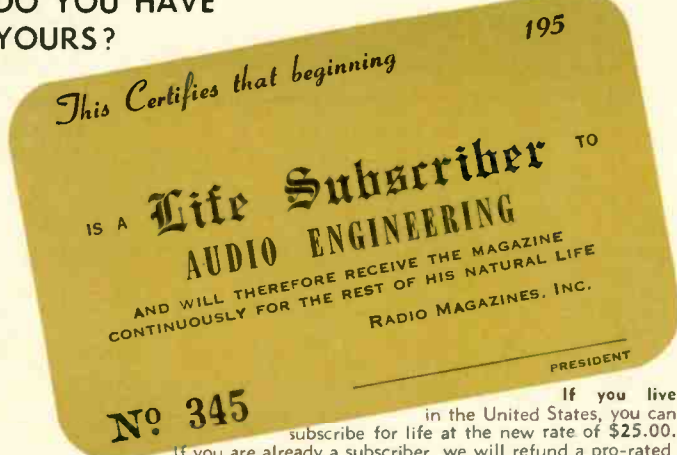

If you live in the United States, you can subscribe for life at the new rate of \$25.00. If you are already a subscriber, we will refund a pro-rated amount based on your remaining term, or you can transfer it to a friend. This offer is good only in the U. S. and applies only to subscriptions entered by sending your check or money order direct to

RADIO MAGAZINES, INC. P. O. BOX 629 MINEOLA, N. Y.



A MONTHLY SUMMARY of product developments and price changes of radio electronic-television parts and equipment, supplied by United Catalog Publishers, Inc. 110 Lafayette Street, New York City, publishers of Radio's Master.

These REPORTS will keep you up-to-date in this ever-changing industry. They will also help you to buy and specify to best advantage. A complete description of most products will be found in the Official Buying Guide, Radio's Master—available through local radio parts wholesalers.

Miscellaneous Radio, TV and Electronic Parts

- BIRNBACH RADIO**—Introduced No. 6261 at \$1.14 net and No. 6263 at \$1.41 net, both hat-handle center of switches of molded bakelite, rated at 3 amps, 250 volts.
- GENERAL CONTROL**—Discontinued Model MX-3. Lightweight foot switch.
- LITTELFUSE**—Added No. 342008 at \$5.55 list to their 3AG fuse extractor post series.
- MERIT TRANSFORMER**—Added No. HVO-9 to their TV component series of horizontal output and hi-voltage transformers at \$6.00 net.
- PORCELAIN PRODUCTS**—Introduced a series of porcelain lead-in tubing for UHF TV cable. This set comes in 7 different lengths from 3 feet to 12 feet, and prevents entry of rain or insects.
- PREMIER METAL PRODUCTS**—Introduced new series ARP, aluminum rack panels.
- R.C.A.**—Added TV component part No. 232T1, universal type horizontal deflection transformer (auto. trans. type) at \$6.30 net.
- RAM ELECTRONIC SALES**—Decreased price on full focus deflection yoke No. Y70F30/3 to \$6.00 net.
- STANDARD TRANSFORMER**—Added deflection yokes No. DY-1A at \$4.74 net . . . No. DY-7A at \$5.37 net . . . No. DY-8A at \$6.60 net . . . No. DY-9A at \$6.60 net and No. DY-10A at \$6.60 net, all with leads and networks added.

Recording Equipment, Speakers, Amplifiers, Needles, Tape, Etc.

- ASTATIC CORP.**—Discontinued Model S-8, crystal pickup arm.
- AUDIO DEVELOPMENT**—Discontinued No. 111A, microphone cable transformer.
- GENERAL ELECTRIC**—Added No. RPX-052 at \$38.95 list and No. RPX-053 at \$57.90 list to their triple play variable reluctance cartridge series. Also added No. RPX-061 at \$33.95 list and No. RPX-063 at \$33.95 list to their variable reluctance cartridge series.
- PACIFIC TRANSDUCER**—Added Model 201D at \$33.00 net. This model is the same as Model 201, a wide-range variable reluctance cartridge with a frequency velocity response to above 12,000 cps and with an output of 60 millivolts, with a diamond stylus instead of a standard sapphire stylus.
- PERMOFLUX CORP.**—Added No. DHS-31B at \$50.00 net to their monaural dynamic headset line. Also added No. PHA-6 at \$8.00 net and PHA-8 at \$13.00 net to their line of headbands.
- RECOTON**—Discontinued their series of juke box osmium phono needles.

Test Equipment

- HYTRON**—Introduced No. SE27, test adapter at \$1.45 net. The test adapter permits easier and faster "topside" chassis testing, since it can be plugged into chassis sockets with the replaced tube plugged into the top of the adapter.
- JACKSON ELECTRICAL INSTR.**—Added Model 710, selenium rectifier test set at \$29.50 net. This pocket size unit tests all selenium rectifiers rated from 20 to 850 ma, and has a variable indicated voltage range from 25 to 300 volts a.c. It is designed to operate on 110 to 125 volts a.e. and includes "line adjust" control to give more accurate readings.
- SIMPSON ELECTRIC**—Increased price on Model 476, Microscope, to \$197.00 net. This oscilloscope uses a 5-in. cathode ray tube mounted in a vertical position, with the image reflected from a high grade mirror mounted in the adjustable cover at the top of the cabinet, bringing the viewing surface near eye level when used on work benches of normal height. Linear sweep frequency is continuously adjustable in five overlapping ranges from 15 to 60,000 cps.

SEE and Hear

Klipschorn Speakers
Dimensiontone Speakers Telemusic
At room 712—L. A. Audio Fair
Crawford's of Beverly Hills
456 North Rodeo Drive
Beverly Hills, California

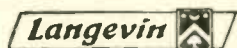

Amplifiers Transformers
Power Supplies

SALES AND SERVICE
THE LANGEVIN CO., INC.
Hollywood • San Francisco

RECORDING HEADS ▶ FOR DISC AND TAPE
STANDARD AND CUSTOM MODELS

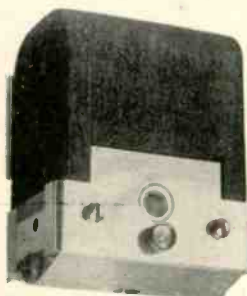

REPAIRS ON ALL MAKES DISC RECORDING HEADS AND REPRODUCERS
DIAMOND STYLUS REPLACEMENTS TAPE HEADS . . . ALL MAKES REBUILT

OLSON DISC RECORDING HEAD
HIGHLY PRECISION HAND-MADE. FLAT TO 15 KC. LOW DISTORTION.

LIPPS TAPE RECORDING HEADS
REASONABLY PRICED. HI OR LOW IMP. GAPS OPTICALLY LAPPED. SPECIAL HEADS TO YOUR SPECIFICATIONS.



EDWIN A. LIPPS ENGINEERING
MICRO ELECTRO-MAGNETIC INSTRUMENTS . . . AUDIO
5485 W. WASHINGTON BLVD., LOS ANGELES 16, CALIF.
WALNUT 4141

ELECTRONIC ENGINEER

Senior Project

We are a nationally known company manufacturing a line of magnetic recording and motion picture equipment. We are looking for a Senior Project Engineer to fill a permanent position created by the rapid expansion of non-military commercial products in the audio sound field. This position is one of considerable responsibility where the Engineer guides a new project from prototype to production. This work involves liaison with Sales, Management and Production Departments as well as development of production designs. This is a position with an excellent opportunity for a man with initiative and ability. Liberal employee benefits. Salary open. Give complete resume of educational background and professional experience.

AMPRO CORPORATION

2835 North Western Ave., Chicago 18, Ill.
BRunswick 8-4500

PROFESSIONAL DIRECTORY

Custom-Built Equipment

U. S. Recording Co.

1121 Vermont Ave., Washington 5, D. C.
LIncoln 3-2705

"EVERYTHING IN HIGH FIDELITY"

From Primary Components
to Completed Custom Audio Equipment

KIERULFF

Sound Corp.

820 West Olympic Blvd. • Los Angeles 15, Calif.
RIchmond 7-0271 ZENith 0271

In Southern California it's HOLLYWOOD ELECTRONICS

(in The Audio Mile)
Distributors of Hi Fidelity
Components Exclusively
Webster 3-8208

7460 Melrose Ave. Hollywood 46, Calif.

Industry People ...

Annual banquet of the Radio Club of America brought forth an assemblage of prominent old-timers long to be remembered—among those present and accounted for were **Paul Godley**, who sent the first Transatlantic message; **Maj. E. H. Armstrong**, who gave us regeneration, the super-het, and FM; **Capt. J. H. Round**, who pioneered radio direction-finding while associated with Marconi; **Harry Houck**, World War I associate of Maj. Armstrong's, who today is president of Measurements Corporation; **Art Odgers**, president of Northern Radio Corporation; **Lincoln Walsh**, designer and manufacturer of the Brook amplifier—and so on far into the night.

Jerry Kahn, president of Stancor, and **Ken Prince**, director of Chicago's annual Electronic Parts Show, made rounds of friends while in Manhattan to conduct drawings for Parts Show exhibit space. . . **Maximilian Weil**, president, Audak Company, appears to be the industry's most consistent lander of publicity in national magazines—currently appearing for a one-month run in the January issue of "House Beautiful" . . . **F. M. Parsons**, vice-president, Kellogg Switchboard and Supply Company, Chicago, announces transfer of general sales offices to 79 W. Monroe St.

Robert W. McElroy has been promoted to newly-created position of director of safety and security for Minnesota Mining & Manufacturing Co. and subsidiaries. . . **Henry C. Roemer**, president, Federal Telephone and Radio Corporation, announces appointment of **Harold R. Hunkins** as chief engineer of company's Selenium-Intellin Division. . . **Wilbur G. Small** is new manager of exhibits for Raytheon Manufacturing Company. . . **Jack Berman**, vice-president in charge of sales for Shure Brothers, Inc., Chicago, for the past 13 years, is resigning to open his own sales rep firm in Southern California effective February first.

Max Baume, formerly sound department director, Hudson Radio & Television Corp., New York, is new sales manager for Brook Electronics, Inc., Elizabeth, N. J. . . New sales and advertising manager for Drake Manufacturing Company, Chicago, is **Rex Mungler**—appointment announced by **Kenneth Foute**, president. . . **Ralph Glover**, product manager of Jensen Manufacturing Company, Chicago, has been named a member of the RTMA's new High-Fidelity committee—he also heads RTMA Loudspeaker committee. . . **Paul V. Pembricks**, formerly head of the methods department, has been upped to assistant plant manager of Hammerlund Manufacturing Company. . . **Allen W. Walz** has been advanced by Arma Corporation to executive staff assistant to **Clifton T. Foss**, vice-president in charge of engineering.

Sidney Harmon, recently resigned as vice-president and general manager, David Bogen, Inc., New York, has acquired half interest in the firm of Harmon-Kardon, Inc., also New York, manufacturers of electronics equipment and audio-visual products—firm formerly was known as Kardon Manufacturing Corp. and was owned outright by **Bernard Kardon**, also a former vice-president and general manager of Bogen. . . **A. J. Nelson Company**, Denver, has been appointed sales representative for Permoflux Corporation in the Rocky Mountain area. . . **Mickey Freeman** has resigned as publicity director of KLAC-TV, Los Angeles, to fulfill similar duties for Hoffman Radio Corporation. . . **Raymond L. Kelley**, with Shure Brothers, Inc., Chicago, since 1946, has been appointed comptroller and vice-president in charge of finance.

Terminal Radio Corp., 85 Cortlandt St., New York, has been named exclusive area distributor of the Travis Tapak—new, self-powered, lightweight, portable tape recorder.

Air-Tone

HEADQUARTERS FOR SOUND EQUIPMENT

COMPLETE LINE OF
COMMERCIAL AND
INDUSTRIAL SYSTEMS



McINTOSH 50 W-2
AMPLIFIER

Largest stock of
High Quality
Amplifiers, from
small single
units to large
rack installa-
tions

Air-Tone

SOUND AND RECORDING CO.
1527 CHESTNUT ST.
PHILA. 2, PA. • RI-6-8388

NOW
Hear This NEW

Jim Lansing

D-130
15" Speaker

New pure iron,
"high intensity"
casting
structure

increases
over-all
efficiency—25%



The heart of a fine loud speaker is its powerful magnetic structure. Jim Lansing engineers have been able to produce in the new D-130 a more powerful magnetic beam across the voice coil than ever before possible. This unique design extends the high frequency response 25% and materially improves the dampening factor. Hear this new Jim Lansing D-130 today . . . at your audio dealer's.

Jim Lansing—first in fine sound!

JAMES B. LANSING SOUND, INC.
2439 Fletcher Drive, Los Angeles 39, California



THE OUTCOME OF FOUR YEARS' WORK

Our first advertisement appeared on this page in January 1949, when we were unknown in the U.S.A. Today, four years later, we are still somewhat surprised at our success in spreading a new concept of musical re-creation throughout the U.S.A.

Our small advertising campaign introduced the 215 speaker, but it was performance that established it as the choice of the man who loves music. At \$54.00 (which includes \$6.00 import duty) it stands as a challenge to all other schools of thought in high-fidelity systems, so much so that its admirers wish to have the rest of the Hartley audio range.

Hitherto, sheer distance has defeated our aim to make this readily available, since we believe that Hartley distribution, with its attendant excellent technical service is desirable for your full enjoyment. This obstacle is now overcome.

In the immediate future H. A. Hartley Co. will have its American headquarters in New York City, with H. A. Hartley as its president and 100% cooperation with London. Demonstration facilities, technical service, and comprehensive stocks will be available for you all. The hazard of the transatlantic crossing will be eliminated, and manufacture, to our existing standards, will be carried out in both New York and London. Your every want will be available for immediate shipment to any part of the United States.

Our increased production facilities will enable us to offer you new and intriguing units and accessories, so that you can have, at low cost and great convenience, a complete Hartley audio installation, with prices which, so far as we can at present estimate, will remain at British levels. These are:

Hartley 215 Speaker \$54.00
Hartley True-bass Baffle \$35.00 (we hope)
Hartley Tone-control Preamplifier \$33.00
Hartley 20 watt Amplifier \$135.00

We shall distribute only through thoroughly qualified dealers operating in exclusive territories, and some territories are still available for audio dealers who want 100% protection against illicit discount granters. We believe the qualified retailer is the cornerstone of the distribution problem. Until dealers are found in each territory we shall supply direct at the prices listed above.

If you are not already on our mailing list, send a postcard today to make sure that you are kept fully informed of a programme that will bring new joy to your home listening at a price you can afford.

H. A. HARTLEY CO. LTD.
152, Hammersmith Road
London W.6, England

ADVERTISING INDEX

Adcola Products, Ltd.	74
Air Tone Sound and Recording Co.	79
Allied Radio Corp.	65
Altec Lansing Corp.	49, 68
Allied Sound Corp.	72
Amperite Co., Inc.	53
Ampex Electric Corp.	11
Ampro Corp.	79
Arnold Engineering Co.	13
Arrow Electronics, Inc.	70
Atlas Sound Corp.	72
Audak Co.	47
Audio Devices, Inc.	Cover 2
Audio Fair—Los Angeles	63
Audio Instrument Co. Inc.	73
Bell Telephone Laboratories	18
Berlant Associates	74
British Industries Corp.	3, 71
Camera Equipment Co.	61
Chicago Transformer Co.	10
Cinema Engineering Co.	64
Classified Ads	76
Conrac Inc.	60
Crawford, Inc.	73
Davis, George Co.	77
Diacoustic Laboratories	71
Electro-Voice Inc.	43
Feldman, Henry Co.	77
Figart's Radio Supply Co.	66
Gates Radio Co.	5
G. & H. Wood Products Co.	65
General Electric Co.	51, 75
Giannini, G. M. & Co. Inc.	2
Hartley, H. A. Co., Ltd.	80
Harvey Radio Co. Inc.	45
Heath Co.	63
Hill, J. T. Sales Co.	77
Hollywood Electronics Co.	67, 79
Hudson Radio & Television Corp.	68
Hughes Research and Development Labs	6
Hycor Co.	57
Kellogg Switchboard & Supply Co.	67
Kierulff Sound Corp.	79
Kittleson Co.	77
Lafayette Radio	52
Langevin Co. Inc.	78
Lansing Sound, James B. Inc.	79
Lasure, Harry A. Co.	77
Leonard Radio, Inc.	59
Lipps, Edwin A.	78
Loukota Co., Douglas H.	77
Lowell Mfg. Co.	73
Magnetic Recorders Company	72
Marshank Sales Co.	77
Maurer, J. A. Inc.	15
McShane Co.	80
Miller, J. W. Co.	80
Minnesota Mining & Mfg. Co.	7
Neely Enterprises	77
Newcomb Audio Products Co.	37
Orradio Industries, Inc.	Cover 3
Owens, Lee	77
Partridge Transformers, Ltd.	75
Perlmuth-Colman and Associates	77
Pickering & Co. Inc.	17
Pilot Radio Corp.	41
Precision Electronics, Inc.	70
Precision Film Laboratories	12
Presto Recording Corp.	39
Professional Directory	79
Radio's Master	54
Reeves Equipment Corp.	73
Reeves Soundcraft Corp.	9
Rek-O-Kut Co.	1
Rockbar Corp.	35
Shure Bros. Inc.	4
Stephens Mfg. Corp.	55
Stone, Carl & Associates	77
Stromberg-Carlson	69
Telex Electro-Acoustic Division	69
Terminal Radio Corp.	74
Tung-Sol Electric Co.	8
Turner Co.	50
United Transformer Co.	Cover 4
University Loudspeakers, Inc.	14
Wallace & Wallace	77
White Sound, Inc.	64
Wholesale Radio Parts Co., Inc.	70
Wiley, John & Sons Co.	74

THE HARTLEY-TUNER 215 SPEAKER

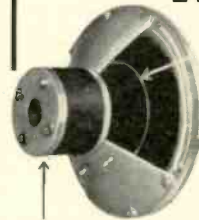

Mid-frequency compliance prevents modulation of treble and mid-frequency's by simultaneously applied sub-audible low frequency content.

Absolutely symmetrical cloth suspended cone gives effect of free air, justifying the Hartley claim of no bass cone resonance — also smooths out impedance — 4 ohms impedance.

(Not shown in illustration) — High frequency's handled by aluminum sleeve inserted between main mass of mid-frequency cone and voice coil and effectively "divided" by a latex mechanical dividing network; nothing like the American style aluminum dome—the Hartley is plus 4 db at 15,000.

The ten-inch Hartley successfully overcomes all the usual limitations on a single voice coil design. H. A. Hartley, London, England, makes no other size, cone shape, or voice coil impedance, feeling that they cannot achieve all the desirable but conflicting characteristics in any other design \$4800 — and feeling, too, that this design represents the pinnacle plus 6.00 import duty of their efforts.

Not widely sold by Distributors. Order by Mail from large Los Angeles stocks! No CODs
McSHANE COMPANY
SHOW ROOMS: 6903 Melrose LOS ANGELES, CALIF.
MAIL ORDERS: 986 Larrabee

Miller
BUILDERS OF QUALITY RADIO INDUCTANCES SINCE 1924

THE SENSATIONAL NEW MILLER BAND-PASS TRF TUNER USING A GERMANIUM DIODE DETECTOR



HIGH FIDELITY
• NO TUBES!
• NO POWER SUPPLY! • NO HUM!
A SIMPLE 2 TUNED CIRCUIT NEGATIVE MUTUAL COUPLED BAND PASS TUNER
• EASY TO ASSEMBLE & WIRE!

In spite of its simplicity, low cost, # 585 kit is not a toy. — It is a carefully designed High Fidelity Broadcast band tuner. Use it with your amplifier and speaker system for truly high quality reception.

The audio output of the tuner is proportional to the input signal and will vary from .05V to .5V for stations within a 20-25 mile radius when used with a good antenna of from 75 to 100 feet in length. A good antenna is absolutely essential to the proper operation of the # 585 tuner.

The net price of the Miller # 585 TRF tuner kit, including chassis, dial, and tuning condenser, is only \$11.40. The additional parts required make it possible to build the complete tuner at a net cost of less than \$15.00.

Order yours now — ask for the new MILLER — Cat. No. 585 Crystal Detector Tuner — Net \$11.40

SEE YOUR LOCAL RADIO PARTS SUPPLIER FOR THE MILLER # 585 KIT AND OTHER MILLER PRODUCTS

J. W. MILLER COMPANY
5917 S. MAIN ST. LOS ANGELES, CALIF.

AT LAST!

no more unscheduled program breaks!

irish SOUND-PLATE

AN ENTIRELY NEW MAGNETIC RECORDING TAPE

It's break-proof...just what you've been wanting



(Produced and Sold Under the
IRISH Label as 22ORPA Red Band
ORRadio Magnetic Tape)

No Other Tape Matches These Sound-Plate Features:

SOUND-PLATE has two times the tensile strength of acetate

SOUND-PLATE will not tear or break

SOUND-PLATE eliminates timing problems —programs on the nose

SOUND-PLATE is unaffected by moisture or temperature change

SOUND-PLATE is engineered for high speed operation, 15 to 500" per sec

SOUND-PLATE is not affected by static

SOUND-PLATE has a greater surface slip

Another Reason WHY SOUND-PLATE is Best For Professional Use!

There are differences in magnetic oxides. ORRadio molecular lubricated oxides are more stable in coating conditions and turn out more uniform dispersions, thus assuring you of the finest recordings possible. SOUND-PLATE is made in the ORRadio tradition.

Here, at last, the sum total of everything you have ever wanted in a professional magnetic recording tape. ORRadio IRISH 22ORPA SOUND-PLATE eliminates your physical problems in magnetic tape recordings. It won't tear or break. It has all the excellent qualities that have made ORRadio IRISH 211RPA the most popular tape among professional engineers.

Yes, SOUND-PLATE costs a little more . . . but, in the long run, it will prove to be not only the most satisfactory, but the most economical magnetic recording tape you can use.

Try SOUND-PLATE at our expense! Buy a-reel of SOUND-PLATE at your favorite Radio Parts Distributor. If you are not completely satisfied, return it to your distributor who has been authorized to refund your money.

1200 Ft. SOUND-PLATE on Plastic Reel \$15.50 List
2400 Ft. SOUND-PLATE on Meta. Reel \$33.85

Manufactured in U.S.A. by

ORRADIO INDUSTRIES, INC. OPELIKA, ALABAMA

World's Largest Exclusive Magnetic Tape Manufacturer

SOUND RECORDING



REG. U.S. PAT. OFF.



PERMALLOY DUST TOROIDS FOR MAXIMUM STABILITY...

The UTC type HQ permalloy dust toroids are ideal for all audio, carrier and supersonic applications. HQA coils have Q over 100 at 5,000 cycles... HQB coils, Q over 200 at 4,000 cycles... HQC coils, Q over 200 at 30 KC... HQD coils, Q over 200 at 60 KC... HQE (miniature) coils, Q over 120 at 10 KC. The toroid dust core provides very low hum pickup... excellent stability with voltage change... negligible inductance change with temperature, etc. Precision adjusted to 1% tolerance. Hermetically sealed.



HQA, HQC, HQD CASE
1 13/16" Dia. x 1 3/16" High



HQB CASE
1 5/8" x 2 5/8" x 2 1/2" High



HQE CASE
1/2 x 1 5/16" x 1 3/16" High

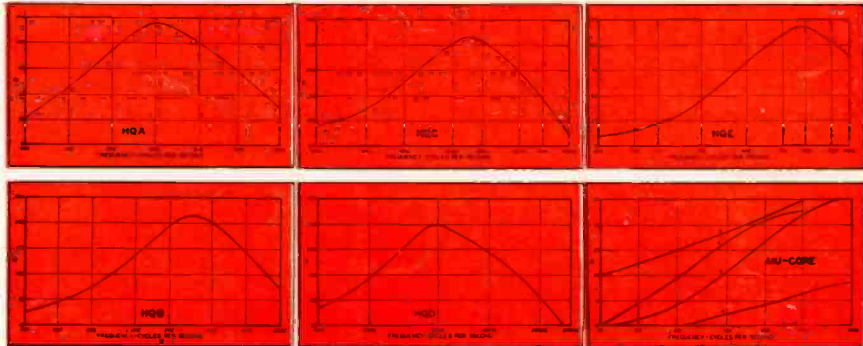

Type No.	Inductance Value	Net Price	Type No.	Inductance Value	Net Price	Type No.	Inductance Value	Net Price
HQA-1	5 mhy.	\$7.00	HQA-16	7.5 hy.	\$15.00	HQC-1	1 mhy.	\$13.00
HQA-2	12.5 mhy.	7.00	HQA-17	10. hy.	16.00	HQC-2	2.5 mhy.	13.00
HQA-3	20 mhy.	7.50	HQA-18	15. hy.	17.00	HQC-3	5 mhy.	13.00
HQA-4	30 mhy.	7.50	HQB-1	10 mhy.	16.00	HQC-4	10 mhy.	13.00
HQA-5	50 mhy.	8.00	HQB-2	30 mhy.	16.00	HQC-5	20 mhy.	13.00
HQA-6	80 mhy.	8.00	HQB-3	70 mhy.	16.00	HQD-1	.4 mhy.	15.00
HQA-7	125 mhy.	9.00	HQB-4	120 mhy.	17.00	HQD-2	1 mhy.	15.00
HQA-8	200 mhy.	9.00	HQB-5	.5 hy.	17.00	HQD-3	2.5 mhy.	15.00
HQA-9	300 mhy.	10.00	HQB-6	1. hy.	18.00	HQD-4	5 mhy.	15.00
HQA-10	.5 hy.	10.00	HQB-7	2. hy.	19.00	HQD-5	15 mhy.	15.00
HQA-11	.75 hy.	10.00	HQB-8	3.5 hy.	20.00	HQE-1	5 mhy.	6.00
HQA-12	1.25 hy.	11.00	HQB-9	7.5 hy.	21.00	HQE-2	10 mhy.	6.00
HQA-13	2. hy.	11.00	HQB-10	12. hy.	22.00	HQE-3	50 mhy.	7.00
HQA-14	3. hy.	13.00	HQB-11	18. hy.	23.00	HQE-4	100 mhy.	7.50
HQA-15	5. hy.	14.00	HQB-12	25. hy.	24.00	HQE-5	200 mhy.	8.00

UTC INTERSTAGE AND LINE FILTERS



FILTER CASE M
1 3/16 x 1 11/16,
1 5/8 x 2 1/2 High

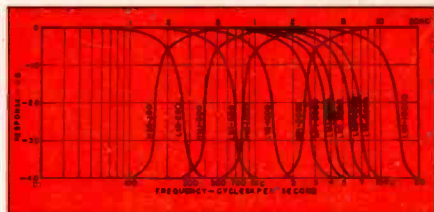
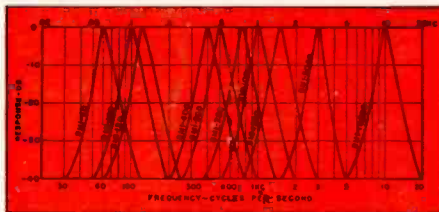

These U.T.C. stock units take care of most common filter applications. The interstage filters, BMI (band pass), HMI (high pass), and LMI (low pass), have a nominal impedance at 10,000 ohms. The line filters, BML (band pass), HML (high pass), and LML (low pass), are intended for use in 500/600 ohm circuits. All units are shielded for low pickup (150 mv/gauss) and are hermetically sealed.

STOCK FREQUENCIES
(Number after letters is frequency)
Net Price \$25.00

BMI-50	BMI-1500	LMI-200	BML-400
BMI-100	BMI-3000	LMI-500	BML-1000
BMI-120	BMI-10000	LMI-1000	HML-200
BMI-400	HMI-200	LMI-2000	HML-500
BMI-500	HMI-500	LMI-3000	LML-1000
BMI-750	HMI-1000	LMI-5000	LML-2500
BMI-1000	HMI-3000	LMI-10000	LML-4000
			LML-12000

United Transformer Co.
150 VARICK STREET • NEW YORK 13, N. Y.

EXPORT DIVISION: 13 EAST 40th STREET, NEW YORK 16, N. Y. CABLES: "ARLAB"